

DIAL DEPTH INDICATOR

SERIES 291

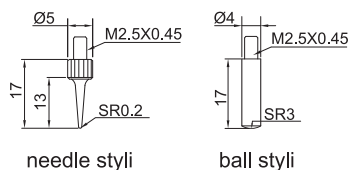

291-010-12



needle styli

ball styli

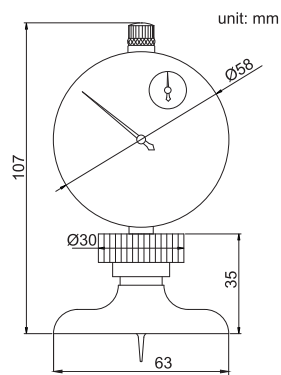

291-010-11

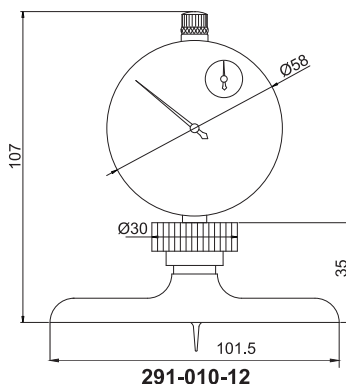

291-010-12

- ◆ Graduation: 0.01mm
- ◆ Indicator travel: 10mm
- ◆ Accuracy: ± 0.03 mm
- ◆ Stainless steel base
- ◆ With needle and ball styli

Code	Range	Base
291-010-11	0-10mm	63x17mm
291-010-12	0-10mm	101.5x17mm

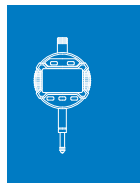

DIAL DEPTH INDICATOR

SERIES 292



292-300-12

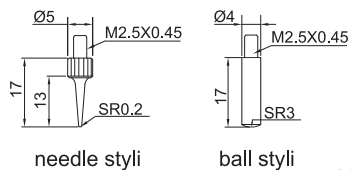

needle styli

ball styli

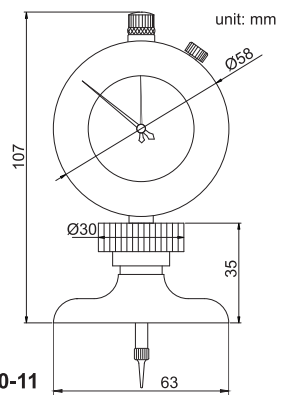

292-300-11

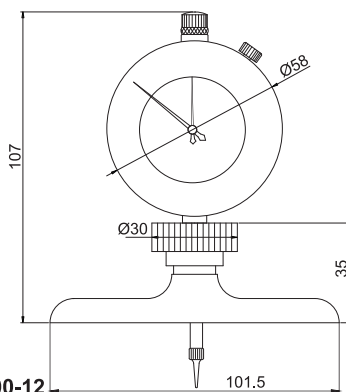

292-300-12

- ◆ Graduation: 0.01mm
- ◆ Indicator travel: 30mm
- ◆ Accuracy: ± 0.03 mm
- ◆ Stainless steel base
- ◆ With needle and ball styli
- ◆ Extension rod: 25mm (1pc), 50mm (1pc), 75mm (1pc), 100mm (2pcs)

Code	Range	Base
292-300-11	0-300mm	63x17mm
292-300-12	0-300mm	101.5x17mm