

GAS PLUS[®]-IR

SERIES 4688-IR COMBUSTIBLE GAS OR CARBON DIOXIDE TRANSMITTER



SCOTT[®]
HEALTH & SAFETY



GAS PLUS[®]-IR TRANSMITTER

SERIES 4688-IR COMBUSTIBLE GAS OR CARBON DIOXIDE TRANSMITTER

The Scott Gas Plus[®]-IR Model 4688 IR Gas Transmitter is a rugged, reliable solution for hydrocarbon or carbon dioxide gas detection. Designed with extensive user input, the instrument is extremely flexible, easy to use, and easy to maintain. This infrared technology is ideally suited for applications where traditional catalytic bead sensors cannot be used due to poisoning and in areas where minimal maintenance is desired.

Principle of Operation

An infrared source emits pulses of radiation into the instrument's "optical bench", which contains a known volume of gas. This radiation is reflected onto two detectors, one tuned to measure a wavelength absorbed by organics and the other tuned to a reference band that is not absorbed. The outputs of the detectors are compared and used to compute gas concentration. Fault conditions are detected by the sensors when radiation intensity falls below a threshold level for a set period of time.

Use and Maintenance

Operation of the Scott Gas Plus[®]-IR Model 4688 IR Gas Transmitter is simple and intuitive. All settings and adjustments, such as alarm set points, gas measured, etc., are non-intrusive, performed at the instrument with a magnetic screwdriver – or remotely through the instrument's RS-485 interface. Password protection prevents unauthorized personnel from tampering with the settings.

Minimal maintenance is necessary. All span information is preset at the factory, and never needs to be adjusted. Zero adjustment is a quick, non-intrusive procedure. On-board diagnostics continuously check transmitter electronics, optics, and software for faults and indicate corrective action should a fault be detected. The field serviceable infrared emitter is replaced with a simple plug-in connection.

Features of the Gas Plus 4688-IR

Low Maintenance

No span calibration required. Zero adjustment is a quick, non-intrusive procedure.

Flexible

Many parameters are user-adjustable, including gas to be detected, decimal precision, damping, and engineering units.

Rugged Design

Conformally coated electronics, stainless steel optics protects components against corrosion, and harsh industrial environments.

Extensive Self Diagnostics

Instrument compensates for detector contamination and aging. Optics are heated to prevent moisture formation. Detailed fault codes aid in troubleshooting.

Multiple Output Choices

4-20mA and RS-485 (Modbus protocol) outputs are standard features. Relays with user adjustable set/reset points, and time delays are available as an option.

User-Friendly Display

Large LCD display shows gas concentration, engineering units, alarm relay status, alarm inhibit, and more.

Low Cost of Ownership

An excellent price/performance ratio and low long-term cost of ownership.



Why IR Technology?

IR technology provides numerous advantages that may be beneficial for your application's conditions.

- Reduced maintenance (no span calibration required)
- No saturation from high gas concentrations
- No oxygen required for operation
- Continuous sensor fault monitoring
- Sensor lifetime not reduced by exposure to gas
- Rapid speed of response
- Minimal temperature and humidity effects
- No poisoning from silicone or other catalytic bead poisons

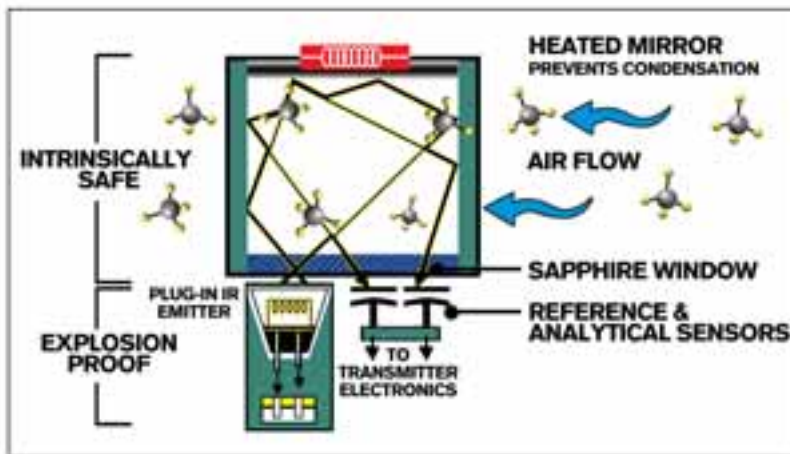

4688-IR Infrared Technology



GAS PLUS ALARM SYSTEM

Engineered to handle difficult industrial environments yet incredibly easy to operate and maintain, the Scott Gas Plus Alarm System provides visual and audible local alarm annunciation in a rugged steel enclosure.

Designed for easy use and maintenance, the Gas Plus Alarm System can be equipped with the Scott 4688IR infrared combustible gas or CO₂ transmitter.

Built-in strobe lights and an 80 db horn respond to two levels of alarm to quickly alert personnel of dangerous, build-ups of combustible gas or CO₂. Three 10 amp relays provide additional response support for your facility, and a front panel light provides continuous visual indication of system status.

The built-in 110 VAC power supply provides simple plug-in electrical connection. Since all system adjustments are non-intrusive, the rugged, painted enclosure never needs to be opened after installation.

INSTALLATION DRAWINGS

ELECTRICAL:

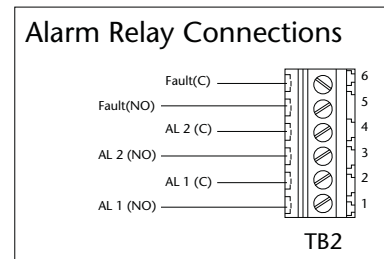
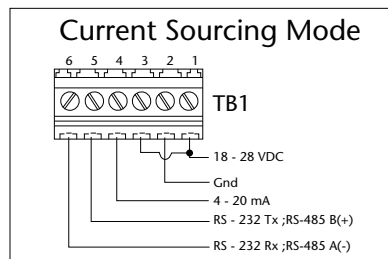
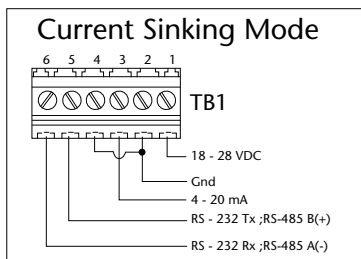

DIMENSIONS:

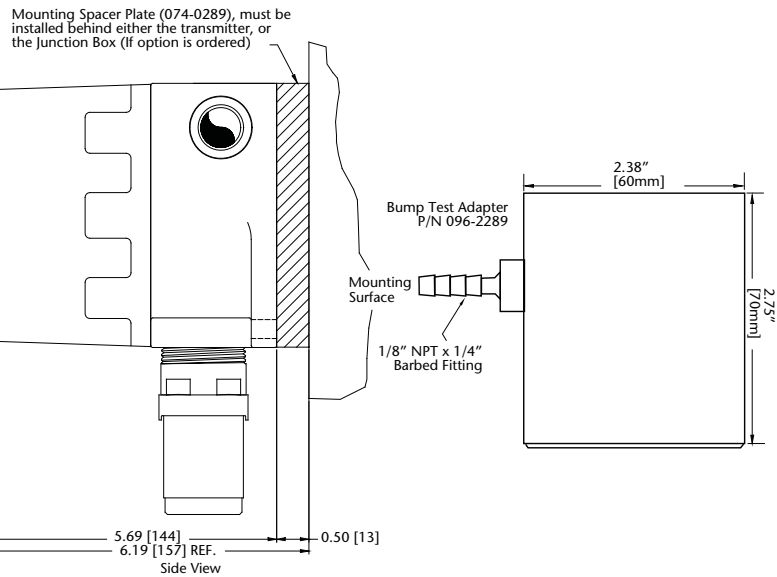
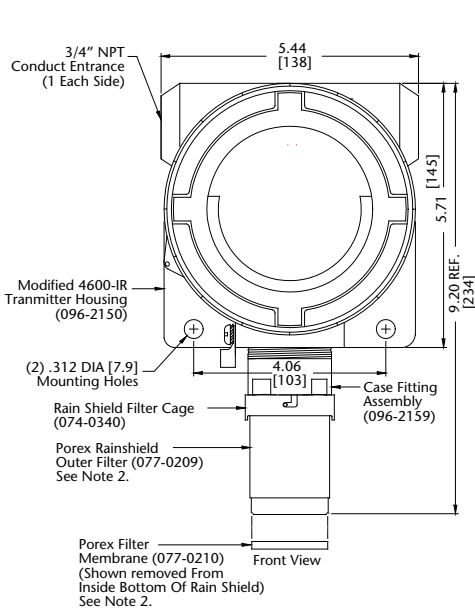

- Notes:
- All Dimensions are shown in inches [mm] and are normal.
 - Replacement filter kits may be ordered as follows:
 - Porex rainshield outer filter replacement kit #096-2274-1 (Qty. of 5 #077-0209 Filters)
 - Porex filter membrane replacement kit #096-2274-2 (Qty. of 5 #077-0210 Filters)
 - Porex main sensor filter (not shown) replacement kit #096-2214 (Qty. of 5 #077-0166 Filters)

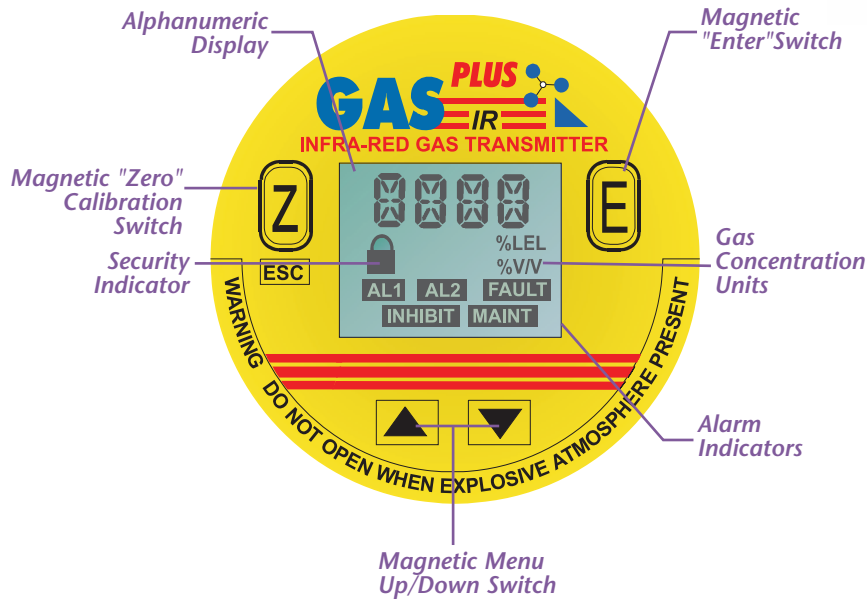

Typical Specifications

1. **General.** Transmitter shall be approved by a nationally recognized testing laboratory for Class 1, Division 1 Group B, C, and D hazardous locations. All parameter settings shall be password protected. A large integral display shall provide visual indication of gas concentration, engineering units, alarm relay and inhibit status.
2. **Temperature and Power.** Transmitter shall operate over an input range of 18-28VDC in ambient conditions of -40°C to 60°C and shall consume no more than 4.0W maximum.
3. **Output.** Transmitter shall provide an isolated, 4-20mA signal, and shall be digitally addressable using MODBUS protocol with RS-485 data transmission. Two SPST alarm relays shall be available as an option. User shall be able to separately adjust alarm set points, reset points, set delays, and reset delays. All alarm parameters shall be password protected and be non-intrusively adjustable through transmitter's front panel via a manufacturer supplied magnet.
4. **Diagnostics.** Transmitter shall conduct self-diagnostics of electronics, software, and sensor at least twice per second. Fault conditions shall be indicated with a specific fault code on the instrument display and with a user-adjustable analog signal. One SPST fault relay shall be available as an option. User shall be capable of testing the alarm and fault relays from the instrument's front panel or remotely via RS-485 communications interface.
5. **Calibration.** All span calibration data shall be preset, with no additional span calibration required by user. Non-intrusive zero calibration shall be performed via magnet. Transmitter shall provide the ability to inhibit its output. A time-out feature shall automatically return the unit to normal operation mode after a preset amount of time. The calibration curve for the gas being monitored shall be user selectable in the field through the transmitter's front panel via a manufacturer supplied magnet.
6. **Sensor.** Sensor shall be non-dispersive infrared type using no moving mechanical parts. Linearity and repeatability shall be $\pm 2\%$ below 40% of full scale, and $\pm 5\%$ at or above 40% of full scale. Infrared emitter shall be field replaceable.

SPECIFICATIONS

SERIES 4688-IR COMBUSTIBLE GAS OR CARBON DIOXIDE TRANSMITTER

GENERAL

Sensor Type	Non-dispersive infrared
Detection Range	See "Gas Types"
Linearity	± 2% below 40% full scale ± 5% from 40% to 110% full scale
Repeatability	± 2% below 40% full scale ± 5% from 40% to 110% full scale
Response Time	T90 < 5 seconds (without rain shield)
Start Up Time	30 seconds
Self-Diagnostic Test2x per second
Calibration	Span: none (factory set) Zero: every 3 to 6 months
User Interface	Non-intrusive via magnet
Display	4 digit LCD with user-adjustable contrast. Numeric display of gas concentration and faults; icons for alarms, lock, and inhibit
Weight	6.5 lbs (3.0 kg)
Warranty	2 years

OUTPUTS

Analog	Isolated, 4-20mA, max loop load 900ohms at 24 VDC (current source or sink)
Programmable Inhibit	1.5 to 20.0mA or RS-485
Programmable Loop Test	1.0 to 20.0mA
Digital	RS-485 using Modbus RTU or Modbus ASCII protocol
Relay (optional)	3 SPST relays (2 concentration, 1 fault), 5A at 250 VAC. User selectable latching/non-latching, energized/de-energized, set/reset delay, and set/reset point

ELECTRICAL

Input Voltage	18-28 VDC
Power Consumption	3.1W, nominal / 6.0W, max
Connections	3 wires or 4 wires (with RS/485 or RS/232 configuration); 18-22 AWG nominal
RFI/EMI	Certified to EN50082-1

ENVIRONMENTAL

Operating Temp	-40°F to 140°F, (-40°C to 60°C)
Operating Humidity	0 to 100% RH

ENCLOSURE

Enclosure Material	Copper-free cast aluminum, baked epoxy finish
Optical Bench Material	Stainless steel

APPROVALS

Enclosure	Explosion proof; UL/FM/CSA, Class 1 Group B,C,D / Class 2, Group E, F / Class 3, NEMA-4X, NEMA-7B, C,D; NEMA-9 E,F,G; IP66
System	ETL listed to UL2279 and UL3111-1 (Class 1, Div 1, Group B,C,D), CE Marked, CSA approved to Class 1, Zone1, Groups IIB+H2; Class I, Groups E,F,&G; Class III, CENELEC approved to EExd[ib] IIC T6

GAS TYPES

For Standard Gases (built-in)

Butane	0-1.9% v/v
Ethane	0-100% LEL or 0-3.0% v/v
Hexane	0-100% LEL or 0-1.1% v/v
Methane	0-100% LEL or 0-5.0% v/v
Pentane	0-100% LEL or 0-1.5% v/v
Propane	0-100% LEL or 0-2.1% v/v
Propylene	0-100% LEL or 0-2.0% v/v
Acetone	0-100% LEL or 0-2.5% v/v
MEK	0-100% LEL or 0-1.5% v/v
Isopropyl Alcohol	0-100% LEL or 0-2.0% v/v
Pure Methane	0-100% LEL or 0-1.9% v/v
Methanol	0-100% LEL or 100% 0-6% v/v
Toluene	0-100% LEL or 0-1.1% v/v
Butadiene	0-100% LEL or 0-2.0% v/v
Ethylene	0-100% LEL or 0-2.7% v/v
Ethanol	0-100% LEL or 0-3.3% v/v
Isobutynol	0-100% LEL or 0-1.7% v/v
Hexane	0-20% v/v
Benzene	0-100% LEL or 0-1.2% v/v
Xylene	0-100% LEL or 0-1.1% v/v
Carbon Dioxide	0-2% v/v

Digital Protocol

RS-485

Accessories

Part #	Description
077-0120	Magnetic Screwdriver
096-2201	RS-485 Termination Board
096-2191	1/4 turn flowcell (Requires Gas Test Adaptor, #096-2192)
074-0321	Rainshield
096-2192	Gas Test Adaptor
096-2289	Bump Test Adaptor
096-2187	Zero Adjustment Kit (includes regulator, tubing, and carrying case - does NOT include methane "bump gas")
096-2190	Gas test kit (2 ft tubing, zero air and methane "bump" gas", cal adaptor, regulator, and carrying case)
096-2215	Porex dust filter (for rainshield) pack of 5
096-2214	Porex dust filter (for sensor) pack of 5
077-0161	Emitter replacement tool
096-2193	IR Emitter (plug-in, includes emitter replacement tool)

Optical Bench Assembly



Mirror Housing assembly
096-2159



Inner Filter
096-2274



Rain Shield Cage
074-0340



Filter Disk
096-2274-2



Outer Filter
096-2274-1