

PSC Series

Wheel type encoder

- Wheel type detection structure which is suitable for the measurement of length and speed
- Various measuring range (6 kinds)
- Economical price
- Simple installation structure

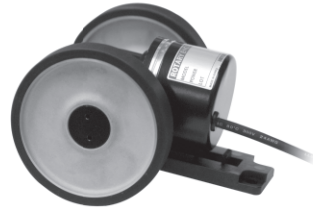

Suffix code

Model	Code				Description
PSC-	<input type="checkbox"/>	<input type="checkbox"/>	<input type="checkbox"/>	<input type="checkbox"/>	Wheel type encoder
Min length measurement	MA				1 m
	MB				1 cm
	MC				1 mm
	YA				1 YARD
	YB				0,1 YARD
	YC				0,01 YARD
Output signal	AB				A, B phase output PSC-MA and PSC-YA are A, B phase output. Rests are A, B, Z Phase output
Output circuit				N	NPN voltage output
				O	NPN open collector
				T	Totem pole output
Power supply voltage				12	12 V DC (5 – 12 V DC)
				24	24 V DC (12 – 24 V DC)



Length measurement code chart

Model	Code	Min measuring length	Gear ratio	Circumference of wheel	Number of pulse per 1 revolution
PSC	MA	1 m	4:1	250 mm	1 pulse
	MB	1 cm	4:1		100 pulse
	MC	1 mm	2:1		500 pulse
	YA	1 YARD	4:1	228,6 mm (0,25/Yd)	1 pulse
	YB	0,1 YARD	4:1		10 pulse
	YC	0,01 YARD	4:1		100 pulse

Specification

Electrical specification

Phase difference on output	Phase difference between the A and B : $T/4 \pm T/8$ (1 cycle of A phase = T)	
Response frequency	100 KHz max.	
Rated voltage	5 – 12 V DC ($\pm 5\%$), 12 – 24 V DC ($\pm 5\%$)	
Current consumption	60 mA max	
Connection type	Cable extended type	
Control output	Voltage and open collector	Load voltage : max 30 V/load current : max 30 mA/Remaining voltage : max 0.4 V
	Totem pole	LOW (Load current : max 30 mA/Remaining voltage : max 0.4 V) HIGH (Load current : max 10 mA/Remaining voltage : Rated voltage above -1.5 V DC)
Response speed	Max 1 μ s (Wire length : 1.5 m Iv sink = 30 mA)	

Mechanical specification

Starting torque	Base on wheel friction coefficient
Max permissible revolution	Gear ratio 4:1 – 1,250 r/min, gear ratio 2:1 – 2,500 r/min (※)

(※) Mechanical endurable maximum revolution.

H
Rotary
Encoder

Environmental specification

Insulation resistance	Min 500 M Ω (Between the terminal and case)
Dielectric strength	500 V AC (For 1 min in 60 Hz between the terminal and case)
Vibration resistance	10 – 55 Hz (Period for 1 min), Double amplitude : 1.5 mm, for 2 hour each in X, Y and Z directions
Shock resistance	735 $\%$ max
Ambient temperature	-10 ~ 70 $^{\circ}$ C (No icing allowed), When storing : -25 ~ 85 $^{\circ}$ C
Ambient humidity	35 ~ 70 % RH
Wire specification	Number of strips : 5 P, Thickness : \varnothing 6.0 mm, Length : 1.5 m, Shield cable
Weight	Approx. 625 g

Dimension (Unit : mm)

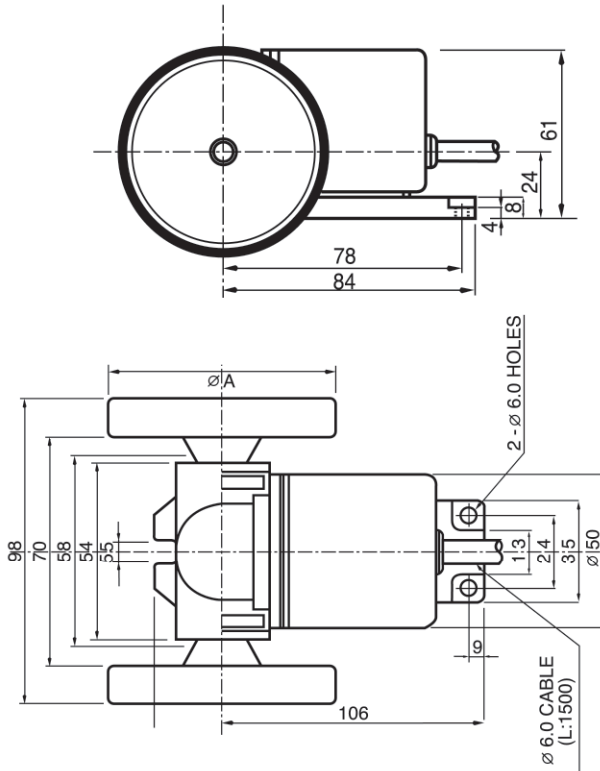

(Note) Please refer to the wheel circumference for the $\varnothing A$ size

Connection diagram

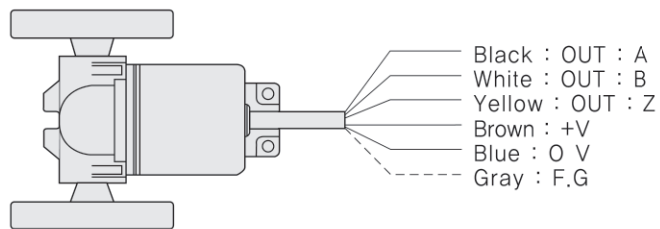

- ※ Please insulate the wires that are not used
- ※ Metal case of encoder and shield line must be earthed (F,G)

Input/output circuit

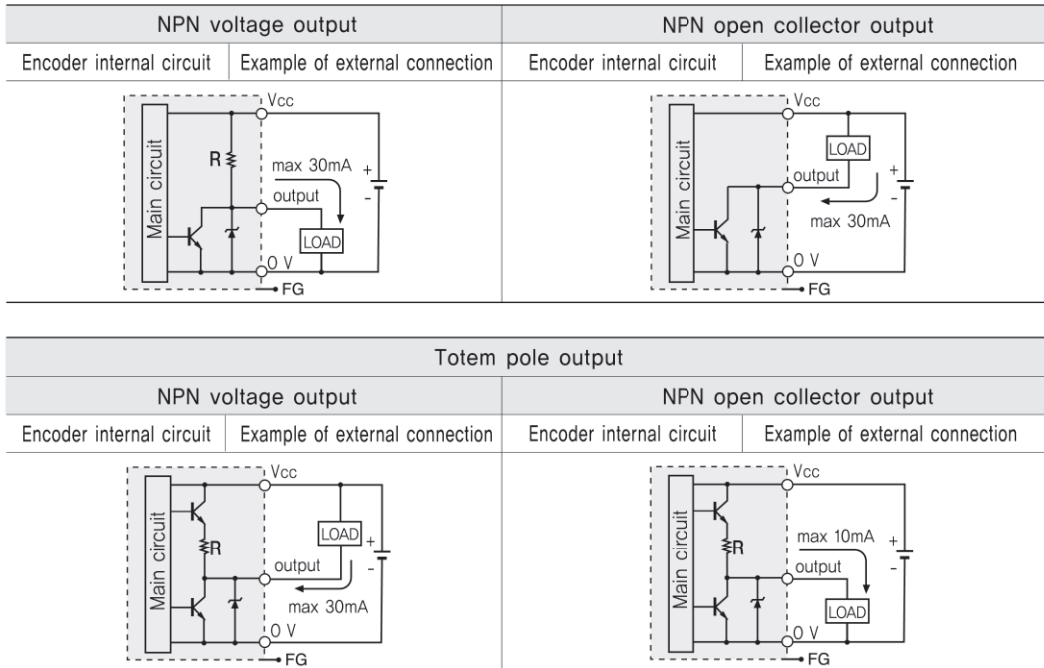

Output wave form

■ NPN voltage output, NPN open collector output, Totem pole output

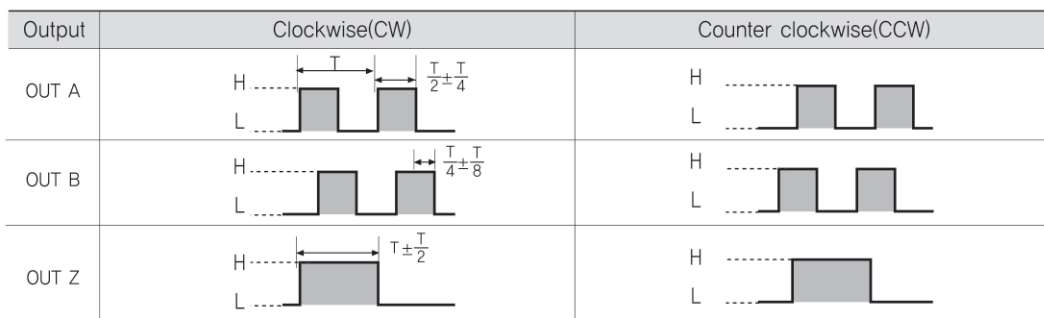

* Clockwise (CW) : Turning to the clockwise direction when looking at from the shaft of the product.

* Counter clockwise (CCW) : Turning to the counter clockwise direction when looking at from the shaft of the product.