

MOM2

Micro-ohmmeter

Megger®



- Up to 220 A
- Battery supplied
- Lightweight – 1 kg
- Safe test – DualGround™
- Auto range: 1 $\mu\Omega$ to 1000 m Ω
- Bluetooth® PC communication
- Complies with IEEE and IEC standards

DESCRIPTION

The MOM2 is designed to measure the resistance of circuit breaker contacts, bus-bar joints and other high-current links. This product is designed with safety, ease of use and versatility in mind.

The micro-ohmmeter can be used anywhere to measure a low resistance value with high accuracy.

MOM2 uses an ultra capacitor to generate the high output current. The ultra capacitor is able to store a huge amount of energy compared to conventional capacitors and can deliver very high current during the discharge thanks to its very low internal resistance.

While testing, the capacitor is discharged through the test object and the voltage drop across- and the current flow through the test object are continuously and synchronously sampled. The resistances calculated from the individual samples are then averaged to obtain the final value.

With MOM2 it is possible to make measurements according to the DualGround™ method. This means that the test object will be grounded on both sides throughout the test giving a safer, faster and easier workflow.

The ruggedness and lightweight makes MOM2 a handheld instrument very suitable for field work, such as in substations. The unit comes with a strong rubber holster accessory which makes it extra durable. MOM2 is dimensioned to make a full day's work of testing without recharge. It can store 104 test values and transfer test data to a PC via Bluetooth.

APPLICATIONS

MOM2 test system is designed to serve a number of applications. The most common are contact resistance measurements of low-, medium- and high-voltage breakers and also at bus-bar joints, and other high current links.

If the contact resistance is too high this will lead to power loss and temperature rise, which often leads to serious trouble. To avoid such problems, it is necessary to check the resistance at regular intervals.

The following table demonstrates how important low resistance is at high currents:

Current	Contact resistance	Power loss
10 kA	1 m Ω	100 kW
10 kA	0.1 m Ω	10 kW
1 kA	1 m Ω	1 kW
1 kA	0.1 m Ω	100 W

At 10 kA a contact with the resistance 0.1 m Ω gives a power loss of 10 kW. This power loss in one single point will definitely confer a temperature rise, which may result in overheating and possibly premature failure.

MOM2 Micro-ohmmeter

FEATURES AND BENEFITS

1. Current output terminal (-)
2. Current output terminal (+)
3. Display
The display offers a combination of analogue arc and a dual digital readout:
 - Analogue arc:
Indicates level of the capacitor charge.
 - Dual digital display:
Large main digital readout for good visibility of all main measurement results
Second digital display for additional data.
4. Ground (earth) terminal
5. Keys for navigation and to make settings in the display
6. TEST-button
7. Stand-by/Wake up (Press shortly to toggle)
Clear log (Press and hold for 5 seconds)

8. Function selector

OFF		
I > I min	0.1 s	Measurement time with minimum current guarantee
	0.6 s	
	3 s	
I = I max	0.1 s	Measurement time with max. charge
	0.6 s	
	3 s	
SET	Bluetooth	Bluetooth "pair units"
	CLK	Set date and time Set volume for the internal loudspeaker Discharge the MOM2 internal capacitor
	I min	Minimum current guarantee setting
	LOG	Data log settings
	P/F	Pass/Fail settings
PC COM		PC communication (dump data to PC)
USER	1	Stored settings. Set from PC, MOM2 Win
	2	
	3	

9. Connector for the voltage (-) sense lead
10. Connector for the voltage (+) sense lead and the trig function
11. Connector for the battery charger
12. Battery charger indicator

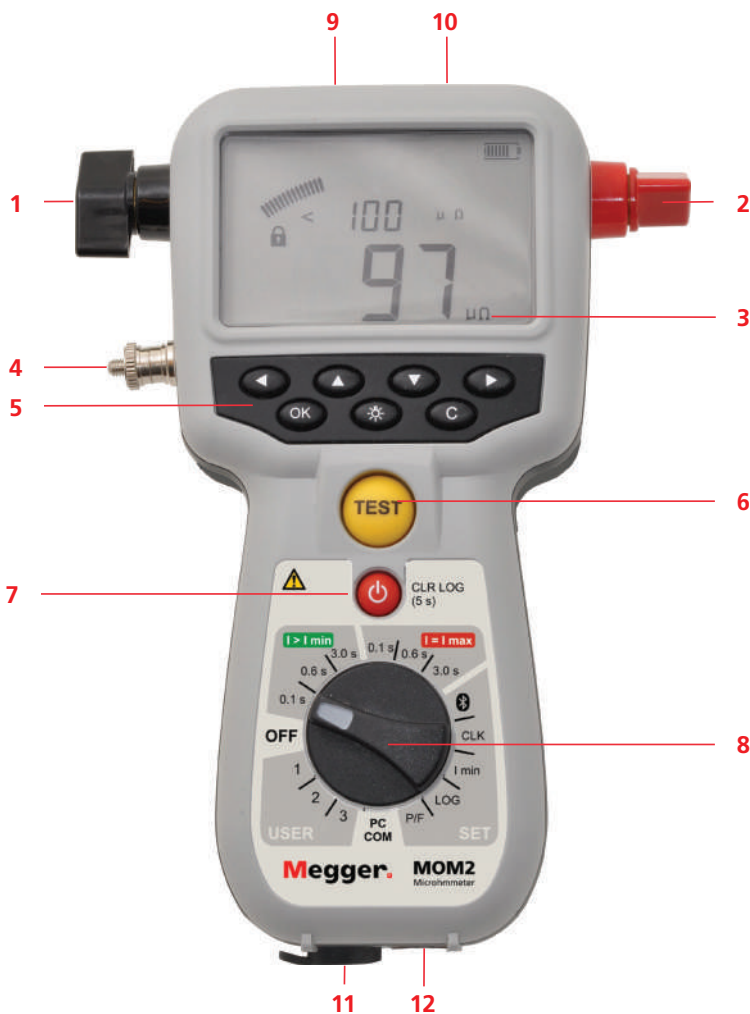

MOM2 Micro-ohmmeter

APPLICATION EXAMPLES

Circuit Breaker testing

- Test of circuit breaker contacts
- Test of the connections to the breaker

Testing of Bus-bar

- Test of Bus-bar joints
- Test of connections

Everywhere you need to test a low resistance/ high current connection

- Switches
- Disconnecting devices
- Safety ground connections
- Welding points
- Fuses
- Cables



Hold probes / attach Kelvin clamps to CB and press trig / TEST button. A signal indicates whether test was pass or fail and result is logged in unit for later dump to PC.

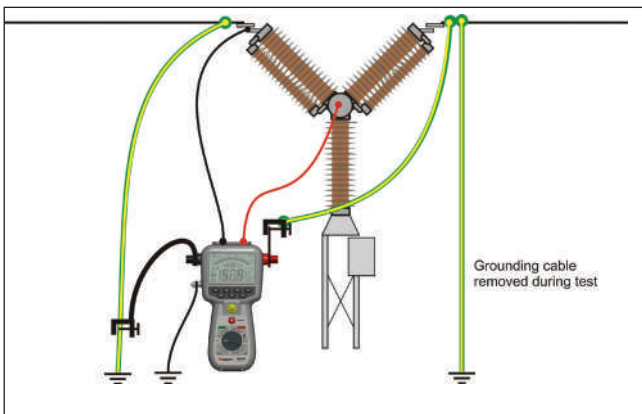

Traditional measurement from ground. Injection is done through existing grounding cable (earthing). Use any of the optional cable kits, GA-00380/82/84, with 5, 10 or 15 m cables.

BOTH SIDES GROUNDED

Many utilities require safety grounds to remain in place during station outages, therefore, the MOM2 was designed with this field safety constraint in mind. DualGround means that the test object will be grounded on both sides throughout the test giving a safer, faster and easier workflow. Minimum time shall be spent in the substation and focus shall be on the test rather than the equipment.

Conventional vs. DualGround	
Site preparation (isolate work area, apply safety ground, issue permit to work)	Site preparation (isolate work area, apply safety ground, issue permit to work)
Hook up test equipment. Issue sanction for test	Hook up test equipment. Issue sanction for test
Authorised person removes the ground	Risky step left out
Perform testing	Safe testing with both sides grounded
Authorised person applies ground	Risky step left out
Cancel sanction for test. Disconnect test equipment	Cancel sanction for test. Disconnect test equipment
Site closing (cancel permit to work, disconnect ground)	Site closing (cancel permit to work, disconnect ground)



Equipment and methods that supports DualGround™ testing are associated with the DualGround symbol. This symbol certifies the use of groundbreaking technology and methods that enables a safe, fast and easy workflow with both sides grounded throughout the test.

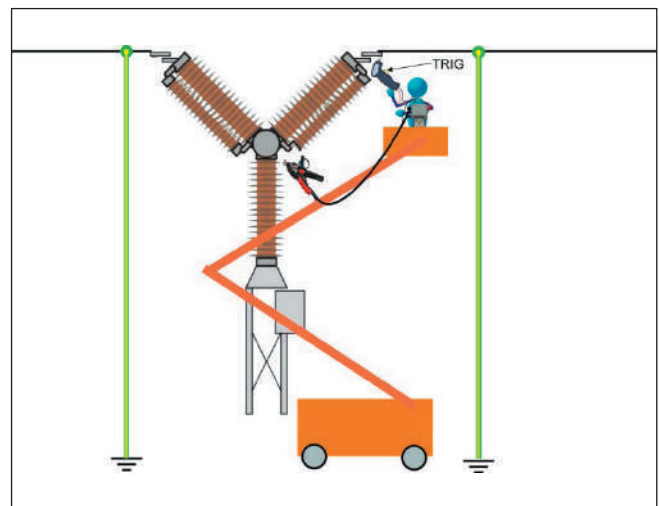

Measurement on CB with both sides grounded, DualGround. Here is a combination of one clamp and one probe used.

MOM2 Micro-ohmmeter

4 WIRE KELVIN TEST

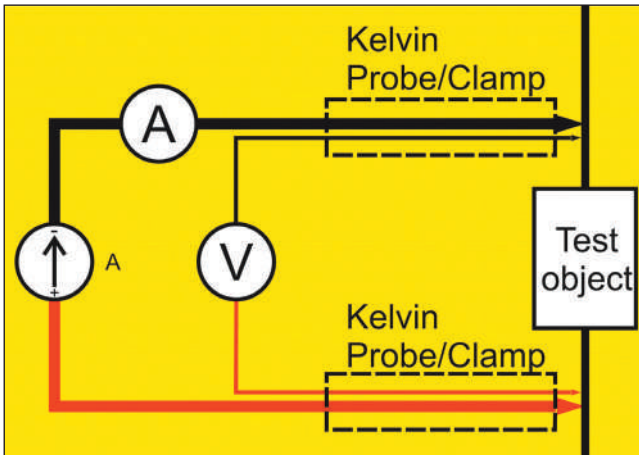

The Kelvin probes (incl. in BD-59090) are used for a 4 wire Kelvin test. This is a way of measuring continuity resistances ensuring all contact and lead resistances are compensated for, which allows a much greater accuracy in measurements. Each Kelvin probe assembly has two probe tips. One tip is for the current generated and the other will measure the very small voltage present.

The Kelvin clamps (incl. in BD-59092) uses the same principle.



Carrying strap that facilitates work when measuring with two probes. Included with instrument.



MOM2 (BD-59092) with Transport case, Charger, Kelvin clamps, Rubber holster, Carrying strap, Belt clip, MOM2 Win.

MOM2 Micro-ohmmeter

SPECIFICATIONS

Specifications are valid at fully charged batteries and an ambient temperature of +25°C, (77°F). Specifications are subject to change without notice.

Environment

Application field For use in high-voltage substations and industrial environments.

Temperature

Operation -20°C to +50°C (-4°F to +122°F) *)

Storage -40°C to +70°C (-40°F to +158°F)

Relative humidity %RH 5%-95%, non condensing

*) Battery operation temperature 0°C to +50° (32°F to +122°F)

Battery charging temperature +10°C to +40° (50°F to +104°F)

CE-marking

EMC 2014/30/EU

LVD 2014/35/EU

RoHS 2011/65/EU

Classifications and standards

Pollution degree 2

Shock IEC 60068-2-27

Vibration IEC 60068-2-6

Transport ISTA 2A

Flammability class V0

General

Battery power Five AA (HR6) 2700 mAh NiMH cells

Recharge time < 12 h

Typical recharge time at 25°C 3 h

Battery charger

Mains voltage 100-250 V AC, 50 / 60 Hz

Power consumption 24 W

Protection Against wrong battery type, low/high temperature.

Real time clock battery life ≥10 years

Audible feedback Different buzzer sounds

User presets 3

Field calibration Yes

Encapsulation IP54

Dimensions

Instrument (excl. binding posts) 217 x 104 x 72 mm

8.5 x 4.1 x 2.8 in.

Carrying case 395 x 300 x 190 mm

15.6 x 11.8 x 7.5 in.

Weight 1.0 kg (2.2 lbs) instrument only

5.0 kg (11 lbs) with accessories and carrying case

Measurement section

Minimum current guarantee Selectable 50 A / 100 A
Valid at resistance ≤2mΩ

Pass / Fail Settable from 1 μΩ to 1999 mΩ

Number of measurements on fully charged batteries typ. 2200 at I min = 50 A and 0.1 s
typ. 800 at I min = 100 A and 0.1 s

Interference suppression Yes

Range 0 - 1000 mΩ

Range selection Auto

Resolution

0 – 999 μΩ 1 μΩ

1.0 – 9.99 mΩ 0.01 mΩ

10.0 – 99.9 mΩ 0.1 mΩ

100 – 1000 mΩ 1 mΩ

Inaccuracy

0 – 1999 μΩ ±1 % of reading ±1 digit

2 – 500 mΩ ±2 % of reading ±1 digit

500 – 1000 mΩ ±4 % of reading ±1 digit

Outputs + / –

Range > 100 A DC (R < 2 mΩ)

Output voltage (max) 2.5 V DC

Generation duration Selectable: 0.1 s, 0.6 s, 3 s

Recovery time at I min set to 100 A and load 100 μΩ

Generation time	Max	Typ
0.1 s	10 s	8 s
0.6 s	20 s	16 s
3 s	130 s	100 s

Inputs

SENSE + / –

Connector 4 mm banana jack

Voltage ±3 V DC

Trigger input Threshold 8 V DC

DC IN 12 – 24 V DC, 2 A max

Logger

Logger, Data Label. Timestamp, I max, I min, I Limit, Resistance, Meas.time, P/F limit

Labeling schemes Circuit breaker oriented or running numbers

Capacity 104 measurements

Wireless communication

PC communication Bluetooth

INCLUDED ACCESSORIES



Test cables with Kelvin probes (incl. in BD-59090)

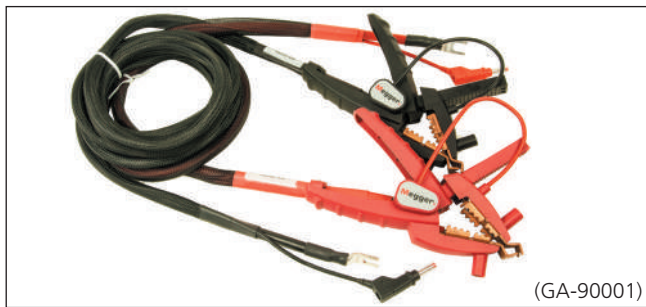

Test cables with Kelvin clamps (incl. in BD-59092)

OPTIONAL ACCESSORIES



Cable kit 5 m (16 ft), (GA-00380)



Calibration kit



Soft carrying case, (GD-00620)

ORDERING INFORMATION

Item	Art. No.
MOM2 <i>Incl.</i> Test cables with Kelvin probes (GA-90000) Transport case, Charger, Rubber holster, Carrying strap, Belt clip, MOM2 Win*	BD-59090
MOM2 <i>Incl.</i> Test cables with Kelvin clamps (GA-90001) Transport case, Charger, Rubber holster, Carrying strap, Belt clip, MOM2 Win*	BD-59092
MOM2 <i>Incl.</i> Test cable red with Kelvin clamp (GA-00373) Test cable black with Kelvin clamp (GA-00374) Transport case, Charger, Rubber holster, Carrying strap, Belt clip, MOM2 Win*	BD-59093
*) MOM2 Win can be downloaded from: " www.megger.com " and search for MOM2	
Optional accessories	
Test cables with Kelvin probes (current & sense) 2 x 1.3 m (4 ft) (one with trig button), 16 mm ²	GA-90000
Test cables with Kelvin clamps (current & sense) 1.3 m (4 ft) red, 3 m (10 ft) black, 16 mm ²	GA-90001
Test cable with Kelvin probe 1.3 m (4 ft) red, 16 mm ² (with trig button)	GA-00370
Test cable with Kelvin probe 1.3 m (4 ft) black, 16 mm ²	GA-00371
Test cable with Kelvin clamp 3 m (10 ft) black, 16 mm ²	GA-00372
Test cable with Kelvin clamp 1.3 m (4 ft) red, 16 mm ²	GA-00373
Test cable with Kelvin clamp 5 m (16 ft) black, 25 mm ²	GA-00374
Test cable with Kelvin clamp 10 m (33 ft) black, 16 mm ² This length in combination with the cable area 16 mm ² results in a reduction of maximum current.	GA-00376
Cable kit 5 m Current cable 0.5 m (1.6 ft), Connection plate and sense cables 5 m (16 ft), Ground cable	GA-00380
Cable kit 10 m Current cable 0.5 m (1.6 ft), Connection plate and sense cables 10 m (33 ft), Ground cable	GA-00382
Cable kit 15 m Current cable 0.5 m (1.6 ft), Connection plate and sense cables 15 m (49 ft), Ground cable	GA-00384
Calibration kit	BD-90002
Soft carrying case For MOM2, Charger and Cables	GD-00620

Postal address
Megger Sweden AB
Box 724
SE-182 17 Danderyd
SWEDEN

T +46 8 510 195 00
E seinfo@megger.com

MOM2_DS_en_V18a
ZI-BD03E • Doc. BD03365E • 2020
Subject to change without notice
Megger Sweden AB
Registered to ISO 9001 and 14001
The word 'Megger' is a registered trademark
www.megger.com

Megger[®]