



Level



Pressure



Flow



Temperature

Liquid  
Analysis

Registration

Systems  
Components

Services



Solutions

## Technical Information

# Omnigrad S TR88, TC88

## Modular Thermometer

TR88 with resistance insert (RTD)

TC88 with thermocouple insert (TC)

Extension neck and threaded connection for installation in an existing thermowell



### Application

- Universal range of application
- Suitable for installation in already existing thermowells
- Measuring range:
  - Resistance insert (RTD):  
–200 to 600 °C (–328 to 1 112 °F)
  - Thermocouple (TC):  
–40 to 1 100 °C (–40 to 2 012 °F)
- Installation without thermowell possible in unpressurized processes
- Degree of protection up to IP68

### Head transmitter

All Endress+Hauser transmitters are available with enhanced accuracy and reliability compared to directly wired sensors. Easy customizing by choosing one of the following outputs and communication protocols:

- Analog output 4 to 20 mA
- HART®
- PROFIBUS® PA
- FOUNDATION Fieldbus™

### Your benefits

- High degree of flexibility thanks to modular design with standard terminal heads as per DIN EN 50446 and customer-specific immersion lengths
- Variable total length in suitable thermowells thanks to compression fitting on extension neck
- Types of protection for use in hazardous locations:
  - Intrinsic Safety (Ex ia)
  - Non-sparking (Ex nA)

## Function and system design

### Measuring principle

#### Resistance thermometer (RTD)

These resistance thermometers use a Pt100 temperature sensor according to IEC 60751. The temperature sensor is a temperature-sensitive platinum resistor with a resistance of 100  $\Omega$  at 0 °C (32 °F) and a temperature coefficient  $\alpha = 0.003851 \text{ } ^\circ\text{C}^{-1}$ .

#### There are generally two different kinds of platinum resistance thermometers:

- **Wire wound (WW):** Here, a double coil of fine, high-purity platinum wire is located in a ceramic support. This is then sealed top and bottom with a ceramic protective layer. Such resistance thermometers not only facilitate very reproducible measurements but also offer good long-term stability of the resistance/temperature characteristic within temperature ranges up to 600 °C (1 112 °F). This type of sensor is relatively large in size and it is comparatively sensitive to vibrations.
- **Thin film platinum resistance thermometers (TF):** A very thin, ultrapure platinum layer, approx. 1  $\mu\text{m}$  thick, is vaporized in a vacuum on a ceramic substrate and then structured photolithographically. The platinum conductor paths formed in this way create the measuring resistance. Additional covering and passivation layers are applied and reliably protect the thin platinum layer from contamination and oxidation, even at high temperatures.

The primary advantages of thin film temperature sensors over wire wound versions are their smaller sizes and better vibration resistance. A relatively low principle-based deviation of the resistance/temperature characteristic from the standard characteristic of IEC 60751 can frequently be observed among TF sensors at high temperatures. As a result, the tight limit values of tolerance category A as per IEC 60751 can only be observed with TF sensors at temperatures up to approx. 300 °C (572 °F). For this reason, thin-film sensors are generally only used for temperature measurements in ranges below 400 °C (932 °F).

#### Thermocouples (TC)

Thermocouples are comparatively simple, robust temperature sensors which use the Seebeck effect for temperature measurement: if two electrical conductors made of different materials are connected at a point, a weak electrical voltage can be measured between the two open conductor ends if the conductors are subjected to a thermal gradient. This voltage is called thermoelectric voltage or electromotive force (emf.). Its magnitude depends on the type of conducting materials and the temperature difference between the "measuring point" (the junction of the two conductors) and the "cold junction" (the open conductor ends). Accordingly, thermocouples primarily only measure differences in temperature. The absolute temperature at the measuring point can be determined from these if the associated temperature at the cold junction is known or is measured separately and compensated for. The material combinations and associated thermoelectric voltage/temperature characteristics of the most common types of thermocouple are standardized in the IEC 60584 and ASTM E230/ANSI MC96.1 standards.

Measuring system

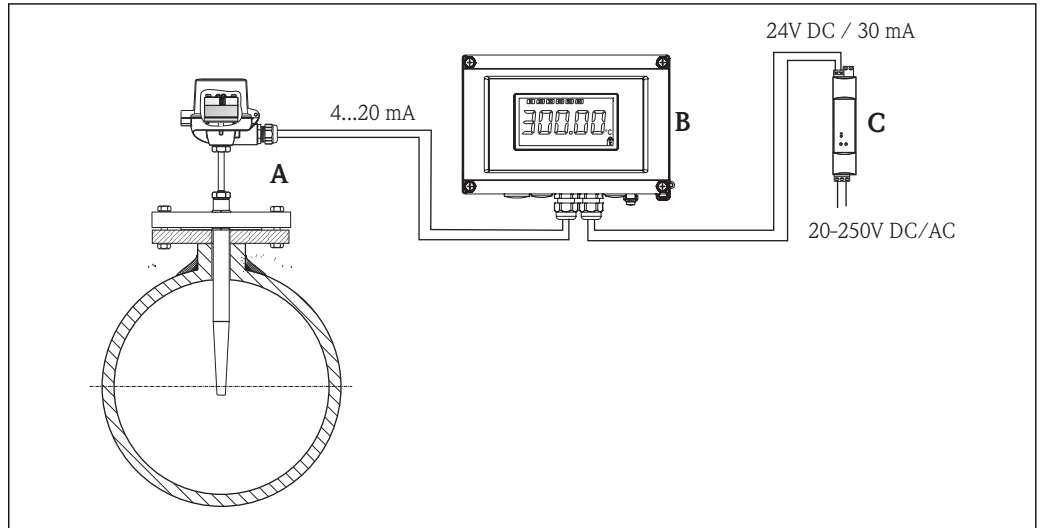

A0012641

1 Application example

- A Thermometer with fitted head transmitter mounted in an existing onsite thermowell
- B RIA16 field display unit - The display unit records the analog measuring signal from the head transmitter and shows this on the display. The LC display shows the current measured value in digital form and as a bar graph indicating a limit value violation. The display unit is looped into the 4 to 20 mA circuit and gets the required energy from there. More information on this can be found in the Technical Information (see "Documentation").
- C Active barrier RN221N - The RN221N (24 V DC, 30 mA) active barrier has a galvanically isolated output for supplying voltage to loop-powered transmitters. The universal power supply works with an input supply voltage of 20 to 250 V DC/AC, 50/60 Hz, which means that it can be used in all international power grids. More information on this can be found in the Technical Information (see "Documentation").

Equipment architecture

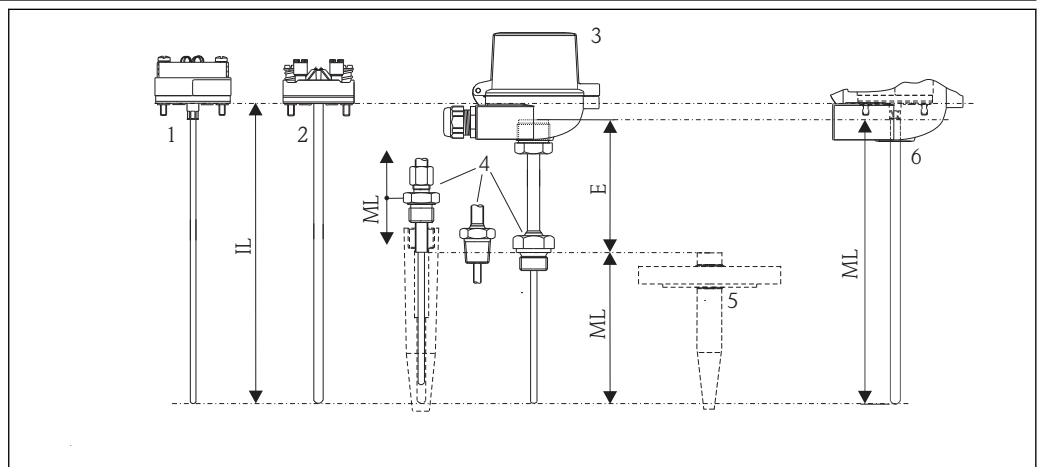

A0012672

2 Thermometer design

- 1 Insert with head transmitter mounted (example with  $\varnothing 3$  mm (0.12 in))
- 2 Insert with terminal block mounted (example with  $\varnothing 6$  mm (0.24 in))
- 3 Complete thermometer with terminal head
- 4 Thermowell connection: Threaded connection or compression fitting on extension neck
- 5 Existing onsite thermowell located in the process
- 6 Version without extension neck, if thermowell and extension neck are present on site in the process ( $E = 0$  mm)
- E Length of extension neck
- IL Insertion length
- ML Insertion length for existing onsite components

Thermometers from the Omnigrad S TR88 and TC88 series have a modular design. The terminal head is used as a connection module for the mechanical and electrical connection of the insert. The position of the actual thermometer sensor in the insert ensures that it is mechanically protected. If installed in a thermowell the insert can be exchanged and calibrated without interrupting the process. The insert has flying leads, a ceramic connection socket or mounted temperature transmitter. The thermometers are designed for installation in an existing onsite thermowell. Different threaded connections are available on the bottom of

the extension neck for installation in the thermowell. Insofar as the thermowell is suited to this purpose, the thermometer may also be mounted using a suitable compression fitting on the extension neck. This means that thermometers with a fixed insertion length (ML) can be used variably, even in thermowells of varying length, and can be installed in such a way that an optimum thermal contact is guaranteed between the tip of the insert and the bottom of the thermowell.

**Measurement range**

- RTD: -200 to 600 °C (-328 to 1 112 °F)
- TC: -40 to 1 100 °C (-40 to 2 012 °F)

## Performance characteristics

**Operating conditions****Ambient temperature**

Terminal head	Temperature in °C (°F)
Without mounted head transmitter	Depends on the terminal head used and the cable gland or fieldbus connector, see 'Terminal heads' section
With mounted head transmitter	-40 to 85 °C (-40 to 185 °F)
With mounted head transmitter and display	-20 to 70 °C (-4 to 158 °F)

**Process pressure**

The maximum process pressure depends on the thermowell into which the thermometer is screwed. For an overview of the Endress+Hauser thermowells which may be used, see (→ [22](#)).

**Permitted flow rate as a function of immersion length**

The maximum permitted flow rate to which the thermometer can be subjected, reduces the greater the immersion depth of the thermowell in the flowing medium. In addition, it is dependent on the diameter of the tip of the thermowell, the medium type, process temperature and process pressure. For an overview of the Endress+Hauser thermowells which may be used, see (→ [22](#)).

**Shock and vibration resistance**

- RTD: 3G / 10 to 500 Hz according to IEC 60751
- TC: 4G / 2 to 150 Hz according to IEC 60068-2-6

**Accuracy**

RTD resistance thermometer as per IEC 60751

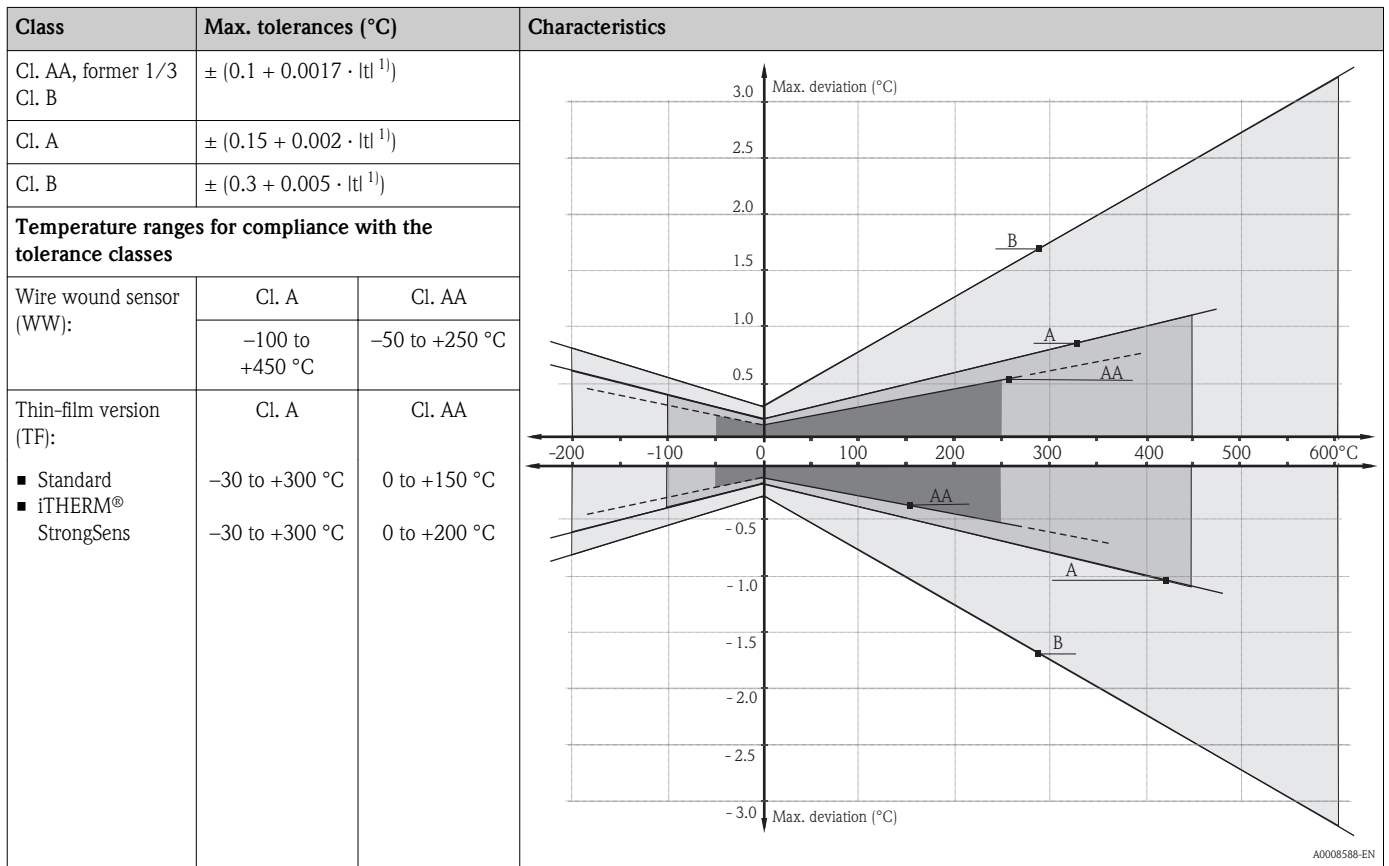

1) |t| = absolute value °C



In order to obtain the maximum tolerances in °F, the results in °C must be multiplied by a factor of 1.8.

Permissible deviation limits of thermoelectric voltages from the standard characteristic for thermocouples as per IEC 60584 or ASTM E230/ANSI MC96.1:

Standard	Type	Standard tolerance		Special tolerance	
		Class	Deviation	Class	Deviation
IEC 60584	J (Fe-CuNi)	2	$\pm 2.5 \text{ °C (-40 to 333 °C)}$ $\pm 0.0075  t ^{1.1} \text{ (333 to 750 °C)}$	1	$\pm 1.5 \text{ °C (-40 to 375 °C)}$ $\pm 0.004  t ^{1.1} \text{ (375 to 750 °C)}$
	K (NiCr-NiAl)	2	$\pm 2.5 \text{ °C (-40 to 333 °C)}$ $\pm 0.0075  t ^{1.1} \text{ (333 to 1200 °C)}$	1	$\pm 1.5 \text{ °C (-40 to 375 °C)}$ $\pm 0.004  t ^{1.1} \text{ (375 to 1000 °C)}$

1) |t| = absolute value °C

Standard	Type	Standard tolerance	Special tolerance
ASTM E230/ANSI MC96.1		Deviation, the larger respective value applies	
	J (Fe-CuNi)	$\pm 2.2 \text{ K or } \pm 0.0075  t ^{1.1} \text{ (0 to 760 °C)}$	$\pm 1.1 \text{ K or } \pm 0.004  t ^{1.1} \text{ (0 to 760 °C)}$
	K (NiCr-NiAl)	$\pm 2.2 \text{ K or } \pm 0.02  t ^{1.1} \text{ (-200 to 0 °C)}$ $\pm 2.2 \text{ K or } \pm 0.0075  t ^{1.1} \text{ (0 to 1260 °C)}$	$\pm 1.1 \text{ K or } \pm 0.004  t ^{1.1} \text{ (0 to 1260 °C)}$

1) |t| = absolute value °C

**Response time**

Tested in accordance with IEC 60751 in flowing water (0.4 m/s at 30 °C):

*Insert:*

Sensor type	Diameter ID	Response time	Thin film (TF)
iTHERM® StrongSens	6 mm (0.24 in)	t <sub>50</sub>	< 3.5 s
		t <sub>90</sub>	< 10 s
TF Sensor	3 mm (0.12 in)	t <sub>50</sub>	2.5 s
		t <sub>90</sub>	5.5 s
	6 mm (0.24 in)	t <sub>50</sub>	5 s
		t <sub>90</sub>	13 s
WW Sensor	3 mm (0.12 in)	t <sub>50</sub>	2 s
		t <sub>90</sub>	6 s
	6 mm (0.24 in)	t <sub>50</sub>	4 s
		t <sub>90</sub>	12 s
Thermocouple (TPC100) grounded	3 mm (0.12 in)	t <sub>50</sub>	0.8 s
		t <sub>90</sub>	2 s
	6 mm (0.24 in)	t <sub>50</sub>	2 s
		t <sub>90</sub>	5 s
Thermocouple (TPC100) ungrounded	3 mm (0.12 in)	t <sub>50</sub>	1 s
		t <sub>90</sub>	2.5 s
	6 mm (0.24 in)	t <sub>50</sub>	2.5 s
		t <sub>90</sub>	7 s



Response time for the sensor assembly without transmitter.

**Insulation resistance**

- RTD:  
Insulation resistance according to IEC 60751 > 100 MΩ at 25 °C between terminals and sheath material measured with a minimum test voltage of 100 V DC
- TC:  
Insulation resistance according to IEC 1515 between terminals and sheath material with a test voltage of 500 V DC:
  - > 1 GΩ at 20 °C
  - > 5 MΩ at 500 °C

**Dielectric strength**

Tested at a room temperature for 5 s:

- Ø6 mm (0.24 in): ≥ 1 000 V DC between terminals and insert sheath
- Ø3 mm (0.12 in): ≥ 250 V DC between terminals and insert sheath

**Self heating**

RTD elements are passive resistances that are measured using an external current. This measurement current causes a self-heating effect in the RTD element itself which in turn creates an additional measurement error. In addition to the measurement current, the size of the measurement error is also affected by the temperature conductivity and flow velocity of the process. This self-heating error is negligible when an Endress+Hauser iTEMP® temperature transmitter (very small measurement current) is connected.

**Calibration**

Endress+Hauser provides comparison temperature calibration from –80 to +1 400 °C (–110 to +2 552 °F) based on the International Temperature Scale (ITS90). Calibrations are traceable to national and

international standards. The calibration certificate is referenced to the serial number of the thermometer. Only the insert is calibrated.

Insert: Ø6 mm (0.24 in) and 3 mm (0.12 in)	Minimum insertion length of insert in mm (in)	
	without head transmitter	with head transmitter
Temperature range		
-80 to -40 °C (-110 to -40 °F)	200 (7.87)	
-40 to 0 °C (-40 to 32 °F)	160 (6.3)	
0 to 250 °C (32 to 480 °F)	120 (4.72)	150 (5.91)
250 to 550 °C (480 to 1020 °F)	300 (11.81)	
550 to 1400 °C (1020 to 2552 °F)	450 (17.72)	

## Material

Extension neck, insert and process connection.

The temperatures for continuous operation specified in the following table are only intended as reference values for use of the various materials in air and without any significant compressive load. The maximum operation temperatures are reduced considerably in some cases where abnormal conditions such as high mechanical load occur or in aggressive media.

Material name	Short form	Recommended max. temp. for continuous use in air	Properties
AISI 316L/ 1.4404 1.4435	X2CrNiMo17-12-2 X2CrNiMo18-14-3	650 °C (1202 °F) <sup>1)</sup>	<ul style="list-style-type: none"> <li>■ Austenitic, stainless steel</li> <li>■ High corrosion resistance in general</li> <li>■ Particularly high corrosion resistance in chlorine-based and acidic, non-oxidizing atmospheres through the addition of molybdenum (e.g. phosphoric and sulfuric acids, acetic and tartaric acids with a low concentration)</li> <li>■ Increased resistance to intergranular corrosion and pitting</li> <li>■ Compared to 1.4404, 1.4435 has even higher corrosion resistance and a lower delta ferrite content</li> </ul>
AISI 316Ti/ 1.4571	X6CrNiMoTi17-12-2	700 °C (1292 °F) <sup>1)</sup>	<ul style="list-style-type: none"> <li>■ Properties comparable to AISI316L</li> <li>■ Addition of titanium means increased resistance to intergranular corrosion even after welding</li> <li>■ Broad range of uses in the chemical, petrochemical and oil industries as well as in coal chemistry</li> <li>■ Can only be polished to a limited extent, titanium streaks can form</li> </ul>
Inconel600/ 2.4816	NiCr15Fe	1100 °C (2012 °F)	<ul style="list-style-type: none"> <li>■ A nickel/chromium alloy with very good resistance to aggressive, oxidizing and reducing atmospheres, even at high temperatures</li> <li>■ Resistant to corrosion caused by chlorine gas and chlorinated media as well as many oxidizing mineral and organic acids, sea water etc.</li> <li>■ Corrosion from ultrapure water</li> <li>■ Not to be used in a sulfur-containing atmosphere</li> </ul>

1) Can be used to a limited extent up to 800 °C (1472 °F) for low compressive loads and in non-corrosive media. Please contact your Endress+Hauser sales team for further information.

---

## Components

---

### Family of temperature transmitters

Thermometers fitted with iTEMP® transmitters are an installation-ready complete solution to improve temperature measurement by significantly increasing accuracy and reliability, when compared to direct wired sensors, as well as reducing both wiring and maintenance costs.

#### PC programmable head transmitters

They offer a high degree of flexibility, thereby supporting universal application with low inventory storage. The iTEMP® transmitters can be configured quickly and easily at a PC. Endress+Hauser offers free configuration software which can be downloaded from the Endress+Hauser Website. More information can be found in the Technical Information.

#### HART® programmable head transmitters

The transmitter is a 2-wire device with one or two measuring inputs and one analog output. The device not only transfers converted signals from resistance thermometers and thermocouples, it also transfers resistance and voltage signals using HART® communication. It can be installed as an intrinsically safe apparatus in Zone 1 hazardous areas and is used for instrumentation in the terminal head (flat face) as per DIN EN 50446. Swift and easy operation, visualization and maintenance by PC using operating software, Simatic PDM or AMS. For more information, see the Technical Information.

#### PROFIBUS® PA head transmitters

Universally programmable head transmitter with PROFIBUS® PA communication. Conversion of various input signals into digital output signals. High accuracy over the complete ambient temperature range. Swift and easy operation, visualization and maintenance using a PC directly from the control panel, e. g. using operating software, Simatic PDM or AMS. For more information, see the Technical Information.

#### FOUNDATION Fieldbus™ head transmitters

Universally programmable head transmitter with FOUNDATION Fieldbus™ communication. Conversion of various input signals into digital output signals. High accuracy over the complete ambient temperature range. Swift and easy operation, visualization and maintenance using a PC directly from the control panel, e.g. using operating software such as ControlCare from Endress+Hauser or NI Configurator from National Instruments. For more information, see the Technical Information.

Advantages of the iTEMP® transmitters:

- Dual or single sensor input (optionally for HART® transmitter)
- Unsurpassed reliability, accuracy and long-term stability in critical processes
- Mathematical functions
- Monitoring of the thermometer drift, sensor backup functionality, sensor diagnostic functions
- Sensor-transmitter matching based on Callendar/Van Dusen coefficients



**Terminal heads**

All terminal heads have an internal shape and size in accordance with DIN EN 50446 flat face and a thermometer connection of M24x1.5, G1/2" or 1/2" NPT thread. All dimensions in mm (in). The cable glands in the diagrams correspond to M20x1.5 connections. Specifications without head transmitter installed. For ambient temperatures with head transmitter installed, see "Operating conditions" section.

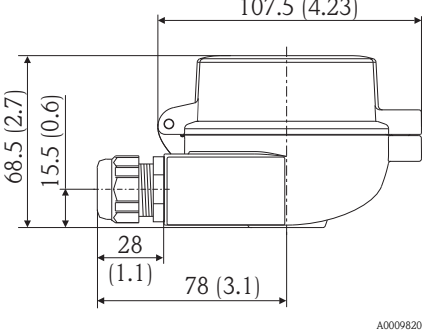
TA30A	Specification
	<ul style="list-style-type: none"> <li>■ Available with one or two cable entries</li> <li>■ Protection class: IP66/68 (NEMA Type 4x encl.)</li> <li>■ Temperature: -50 to +150 °C (-58 to +302 °F) without cable gland</li> <li>■ Material: aluminum, polyester powder coated</li> <li>■ Seals: silicone</li> <li>■ Threaded cable entry: G 1/2", 1/2" NPT and M20x1.5;</li> <li>■ Protection armature connection: M24x1.5</li> <li>■ Head color: blue, RAL 5012</li> <li>■ Cap color: gray, RAL 7035</li> <li>■ Weight: 330 g (11,64 oz)</li> <li>■ Ground terminal, internal and external</li> <li>■ 3-A® marked</li> </ul>

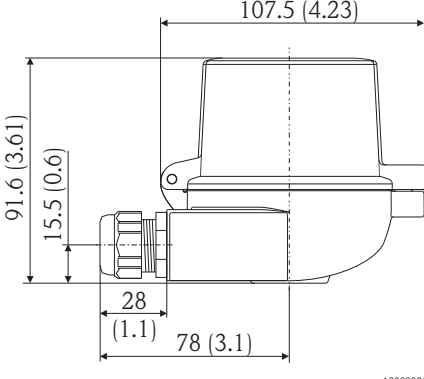
TA30A with display window	Specification
	<ul style="list-style-type: none"> <li>■ Available with one or two cable entries</li> <li>■ Protection class: IP66/68 (NEMA Type 4x encl.)</li> <li>■ Temperature: -50 to +150 °C (-58 to +302 °F) without cable gland</li> <li>■ Material: aluminum, polyester powder coated</li> <li>■ Seals: silicone</li> <li>■ Threaded cable entry: G 1/2", 1/2" NPT and M20x1.5</li> <li>■ Protection armature connection: M24x1.5</li> <li>■ Head color: blue, RAL 5012</li> <li>■ Cap color: gray, RAL 7035</li> <li>■ Weight: 420 g (14,81 oz)</li> <li>■ Head transmitter optional with TID10 display</li> <li>■ Ground terminal, internal and external</li> <li>■ 3-A® marked</li> </ul>

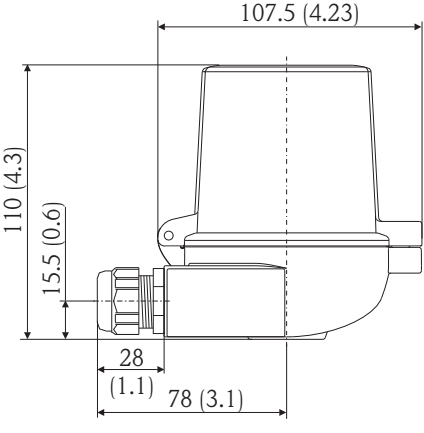
TA30D	Specification
	<ul style="list-style-type: none"> <li>■ Available with one or two cable entries</li> <li>■ Protection class: IP66/68 (NEMA Type 4x encl.)</li> <li>■ Temperature: -50 to +150 °C (-58 to +302 °F) without cable gland</li> <li>■ Material: aluminum, polyester powder coated</li> <li>■ Seals: silicone</li> <li>■ Threaded cable entry: G 1/2", 1/2" NPT and M20x1.5</li> <li>■ Protection armature connection: M24x1.5</li> <li>■ Two head transmitters can be mounted. In the standard version, one transmitter is mounted in the terminal head cover and an additional terminal block is installed directly on the insert.</li> <li>■ Head color: blue, RAL 5012</li> <li>■ Cap color: gray, RAL 7035</li> <li>■ Weight: 390 g (13.75 oz)</li> <li>■ Ground terminal, internal and external</li> <li>■ 3-A® marked</li> </ul>

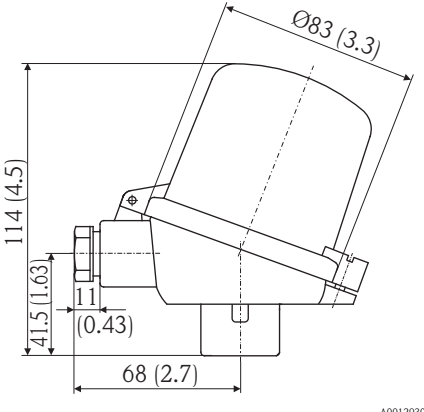
TA30P	Specification
	<ul style="list-style-type: none"> <li>■ Protection class: IP65</li> <li>■ Max. temperature: -40 to +120 °C (-40 to +248 °F)</li> <li>■ Material: polyamide (PA), antistatic</li> <li>■ Seals: silicone</li> <li>■ Threaded cable entry: M20x1.5</li> <li>■ Protection armature connection: M24x1.5</li> <li>■ Head and cap color: black</li> <li>■ Weight: 135 g (4.8 oz)</li> <li>■ Types of protection for use in hazardous locations: Intrinsic Safety (G Ex ia)</li> <li>■ Ground terminal: only internal via auxiliary clamp</li> </ul>

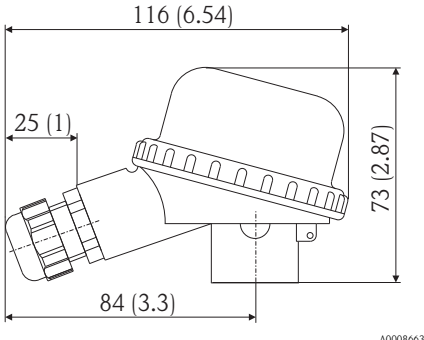
TA20B	Specification
	<ul style="list-style-type: none"> <li>■ Protection class: IP65</li> <li>■ Max. temperature: 80 °C (176 °F)</li> <li>■ Material: polyamide (PA)</li> <li>■ Cable entry: M20x1.5</li> <li>■ Head and cap color: black</li> <li>■ Weight: 80 g (2.82 oz)</li> <li>■ 3-A® marked</li> </ul>

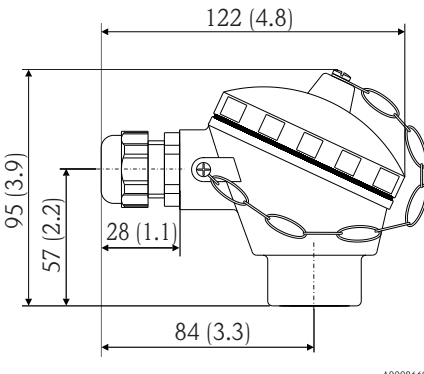
TA21E	Specification
	<ul style="list-style-type: none"> <li>■ Protection class: IP65</li> <li>■ Max. temperature: 130 °C (266 °F) silicone, 100 °C (212 °F) rubber seal without cable gland (observe max. permitted temperature of the cable gland!)</li> <li>■ Material: aluminum alloy with polyester or epoxy coating, rubber or silicone seal under the cover</li> <li>■ Cable entry: M20x1.5 or plug M12x1 PA</li> <li>■ Protection armature connection: M24x1.5, G 1/2" or NPT 1/2"</li> <li>■ Head color: blue, RAL 5012</li> <li>■ Cap color: gray, RAL 7035</li> <li>■ Weight: 300 g (10.58 oz)</li> <li>■ 3-A® marked</li> </ul>

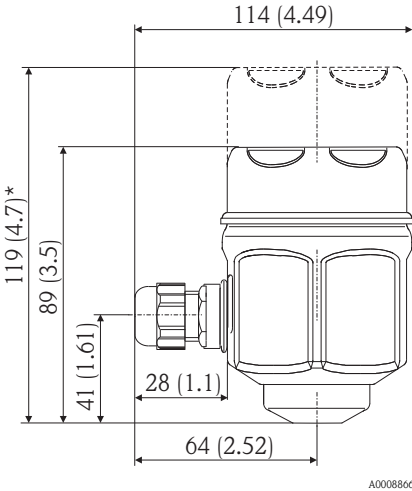
TA20J	Specification
 <p>* Abmessungen mit optionaler Anzeige</p>	<ul style="list-style-type: none"> <li>■ Protection class: IP66/IP67</li> <li>■ Max. temperature: 70 °C (158 °F)</li> <li>■ Material: 316L (1.4404) stainless steel, rubber seal under the cover (hygienic design)</li> <li>■ 4 digits 7-segments LC display (loop powered with optional 4 to 20 mA transmitter)</li> <li>■ Cable entry: 1/2" NPT, M20x1.5 or plug M12x1 PA</li> <li>■ Protection armature connection: M24x1.5 or 1/2" NPT</li> <li>■ Head and cap color: stainless steel, polished</li> <li>■ Weight: 650 g (22.93 oz) with display</li> <li>■ Humidity: 25 to 95 %, no condensation</li> <li>■ 3-A® marked</li> </ul> <p>The programming is executed through 3 keys at the bottom of the display.</p>

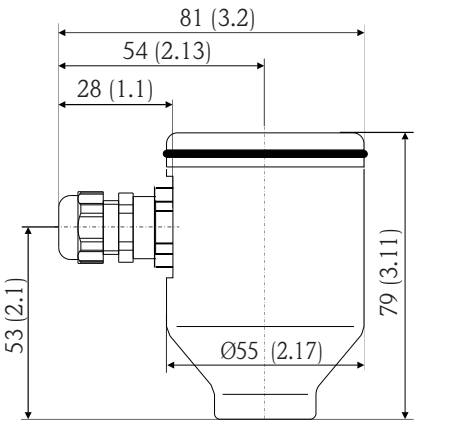
TA20R	Specification
	<ul style="list-style-type: none"> <li>■ Protection class: IP66/67</li> <li>■ Max. temperature: 100 °C (212 °F)</li> <li>■ Material: SS 316L (1.4404) stainless steel</li> <li>■ Cable entry: 1/2" NPT, M20x1.5 or plug M12x1 PA</li> <li>■ Head and cap color: stainless steel</li> <li>■ Weight: 550 g (19.4 oz)</li> <li>■ LABS-free</li> <li>■ 3-A® marked</li> </ul>

Maximum ambient temperatures for cable glands and fieldbus connectors	
Type	Temperature range
Cable gland 1/2" NPT, M20x1.5 (non Ex)	-40 to +100 °C (-40 to +212 °F)
Cable gland M20x1.5 (for dust ignition-proof area)	-20 to +95 °C (-4 to +203 °F)
Fieldbus connector (M12x1 PA, 7/8" FF)	-40 to +105 °C (-40 to +221 °F)

## Design

All dimensions in mm (in).

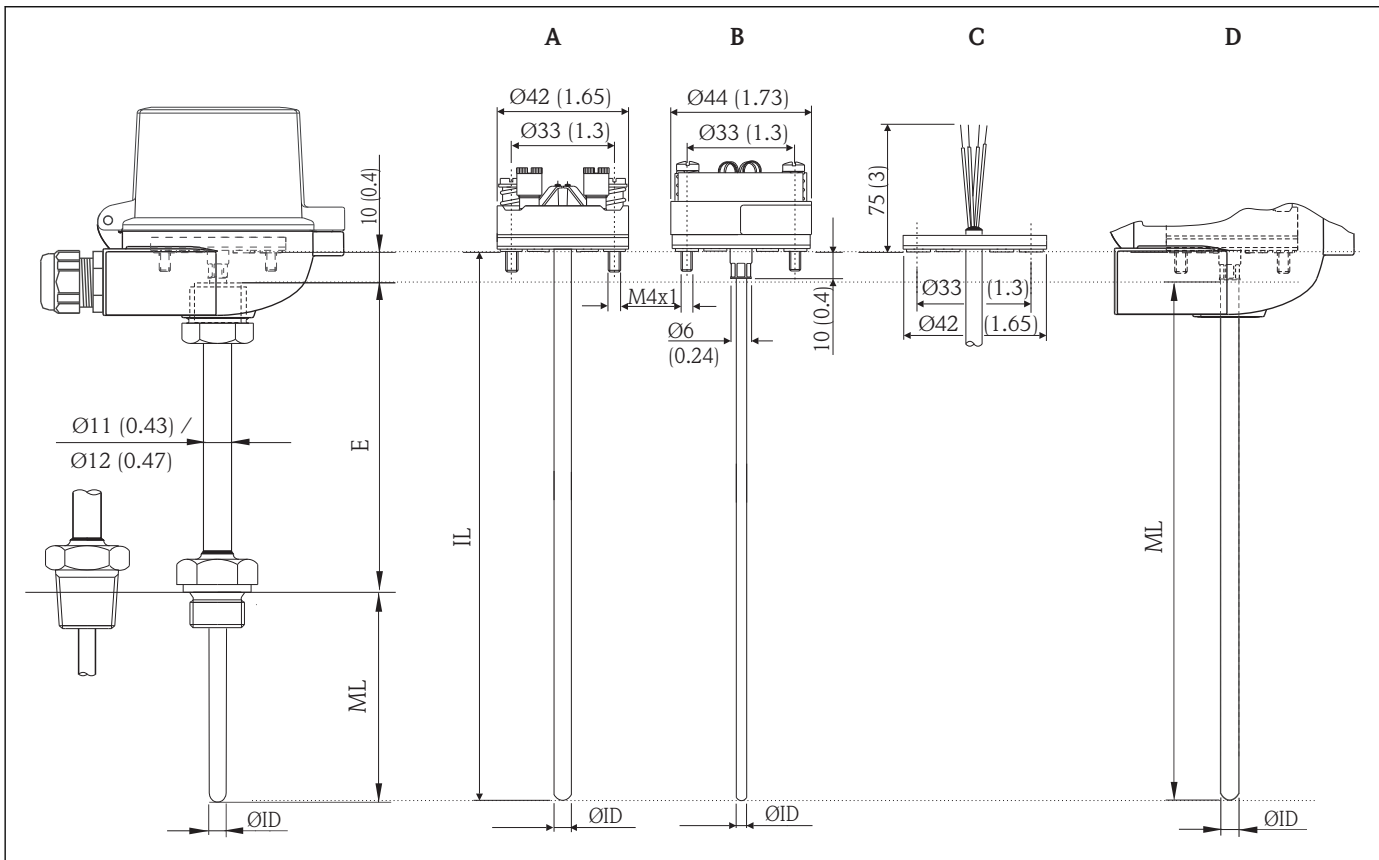

A0012662

3 Dimensions of the Omnigrad S TR88 and TC88

- A Insert with terminal block mounted
- B Insert with head transmitter mounted
- C Insert with flying leads
- D Model without extension neck, intended for mounting in an existing onsite extension neck
- E Extension neck length
- IL Total length of insert
- ML Insertion length
- ØID Insert diameter

**i** The insertion length (ML) must be selected on the basis of the total length and the **type of thermowell used**.

**Insert**

Depending on the application different inserts are available for the assembly:

Sensor	Standard thin-film	iTHERM® StrongSens	Wire wound	
<b>Sensor design; connection method</b>	1x Pt100, 3- or 4-wire, mineral insulated	1x Pt100, 3- or 4-wire, mineral insulated	1x Pt100, 3- or 4-wire, mineral insulated	2x Pt100, 3-wire, mineral insulated
<b>Vibration resistance of the insert tip</b>	Up to 3g	Enhanced vibration resistance > 60g	Up to 3g	
<b>Measuring range; accuracy class</b>	-50 to +400 °C (-58 to +752 °F), Class A or AA	-50 to +500 °C (-58 to +932 °F), Class A or AA	-200 to +600 °C (-328 to +1 112 °F), Class A or AA	
<b>Diameter</b>	3 mm (1/8 in), 6 mm (1/4 in)	6 mm (1/4 in)	3 mm (1/8 in), 6 mm (1/4 in)	
<b>Insert type</b>	TPR100	iTHERM® TS111	TPR100	

TC				
Selection in order code	A	B	E	F
<b>Sensor design; material</b>	1x K; INCONEL600	2x K; INCONEL600	1x J; 316L	2x J; 316L
<b>Measuring range acc. to:</b>				
<b>DIN EN 60584</b>	-40 to 1 200 °C		-40 to 750 °C	
<b>ANSI MC 96.1</b>	0 to 1 250 °C		0 to 750 °C	
<b>TC Standard, accuracy</b>	IEC 60584-2; class 1 ASTM E230-03; special			
<b>Insert type</b>	TPC100			
<b>Diameter</b>	Ø3 mm (0.12 in) or Ø6 mm (0.24 in), depending on the selected tip shape			

**Weight**

0.5 to 2.5 kg (1 to 5.5 lbs) for standard options.

**Process connection**

The thermometer is designed for installation in an existing onsite thermowell or in a thermowell which can be ordered separately. The installation is done using the threaded connection on the bottom of the extension neck or using a compression fitting.

Threaded connection		Version		Thread length TL	Width across flats AF
Cylindrical	Conical	M	M14x1.5	12 mm (0.47 in)	17
			M18x1.5		24
			M20x1.5	15 mm (0.6 in)	24
		G	G 1/2"	15 mm (0.6 in)	27
		NPT	NPT 1/2"	8 mm (0.32 in)	22
		R	R 3/4"	8.5 mm (0.33 in)	27
			R 1/2"		22

Threaded compression fitting (TA50)	F	L	B	Clamping ring material	Max. process temperature	Max. process pressure
	G1/2"	47 mm (1.85 in)	15 mm (0.6 in)	SS316 <sup>1)</sup>	500 °C (932 °F)	40 bar at 20 °C (580 psi at 68 °F)

1) SS316 compression ferrule: Can only be used once, the compression fitting cannot be repositioned on the protection tube after loosening. Fully adjustable immersion length on initial installation.

When using a compression fitting the thermometer is pushed through a gland and fixed using a metal ferrule (cannot be loosened).

**Spare parts**

- The RTD insert is available as spare part TPR100 (→ 22)
- Der iTHERM® StrongSens is available as spare part TS111 (→ 22)
- The TC insert is available as spare part TPC100 (→ 22)

The inserts are made from mineral insulated cable (MgO) with a sheath in AISI316L/1.4404 (RTD) or Inconel600 (TC).

If spare parts are required, refer to the following equation:

**Insertion length IL = E + L + 10 mm (0.4 in)**

- Extension neck welded with threaded connection to terminal head. DIN flat face, different connections to separate thermowell, **order number TN15-...**
- Compression fitting with thread, Ø12 mm (0.47 in), process connection thread G1/2", clamping ring made of 316L stainless steel, **order number TA50-KC**

# Wiring

## Wiring diagrams for RTD

Type of sensor connection

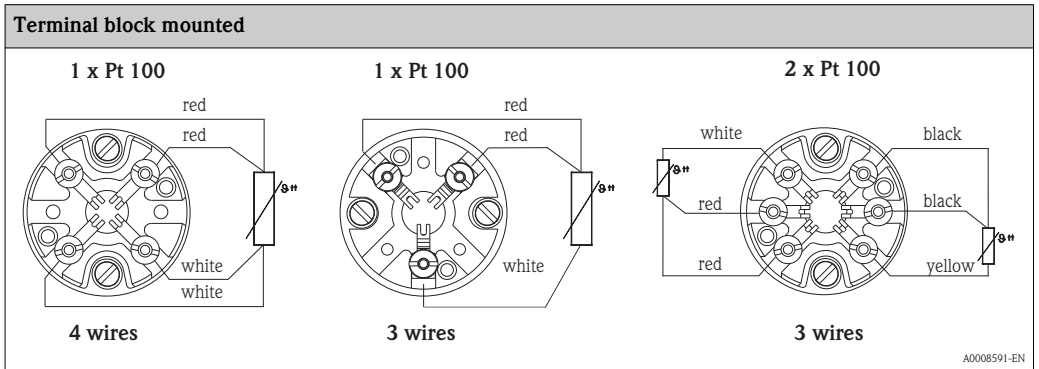
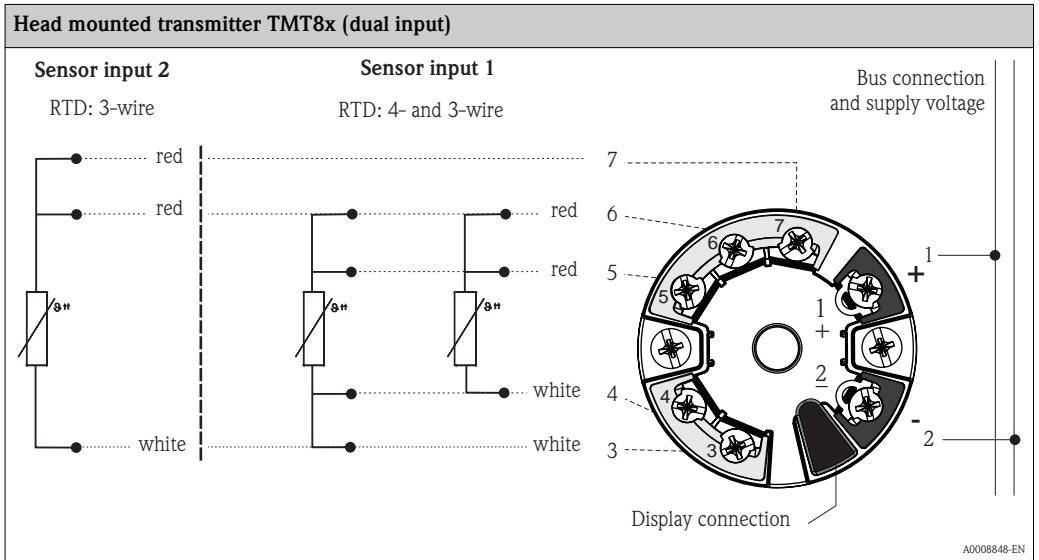
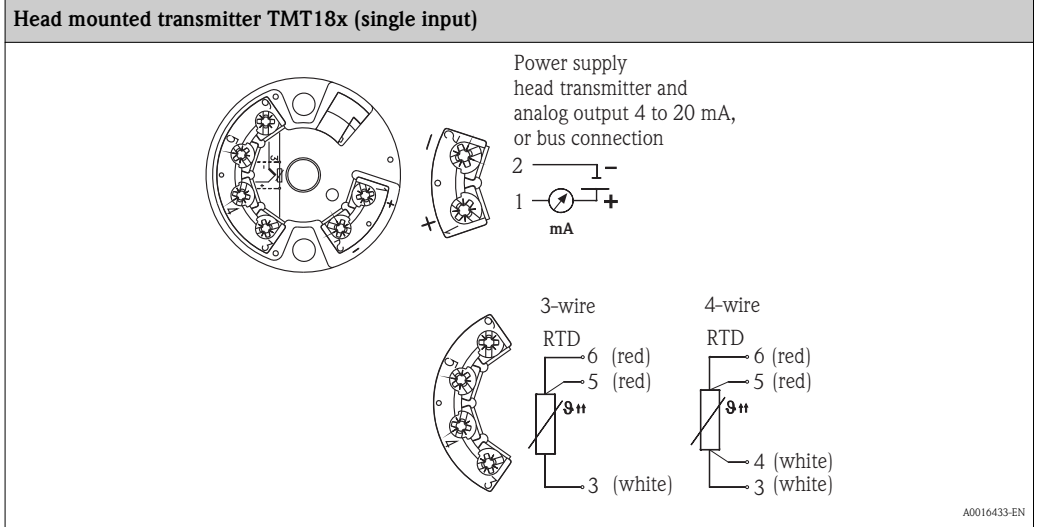

Wiring diagrams for TC

Thermocouple wire colors

As per IEC 60584	As per ASTM E230
<ul style="list-style-type: none"> <li>■ Type J: black (+), white (-)</li> <li>■ Type K: green (+), white (-)</li> </ul>	<ul style="list-style-type: none"> <li>■ Type J: white (+), red (-)</li> <li>■ Type K: yellow (+), red (-)</li> </ul>

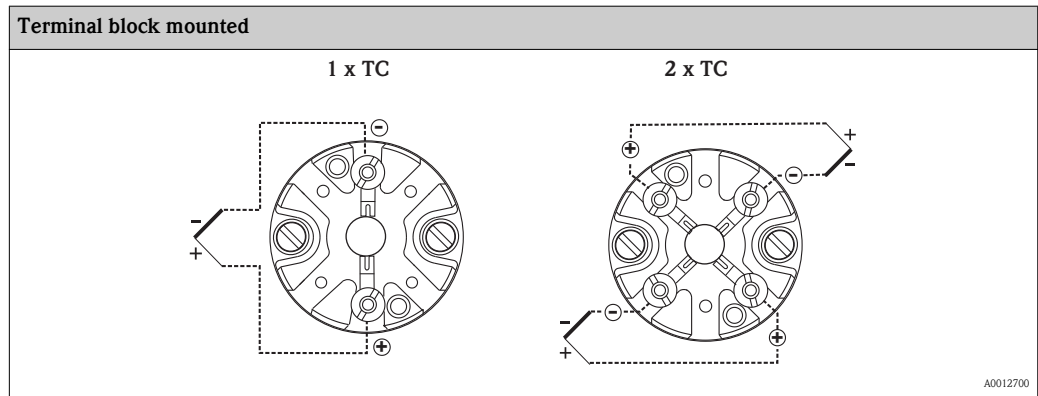
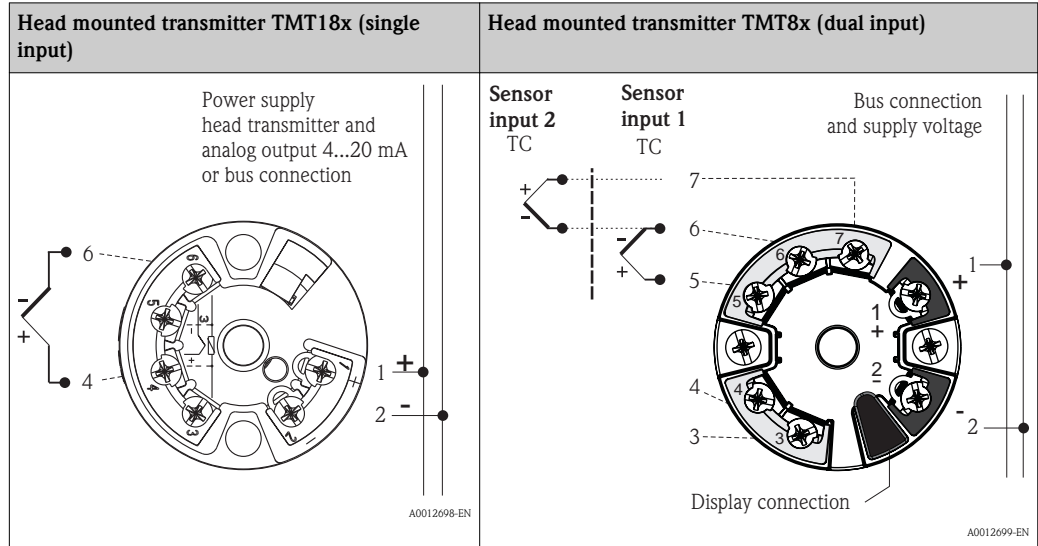



## Installation conditions

**Orientation** No restrictions.

### Installation instructions

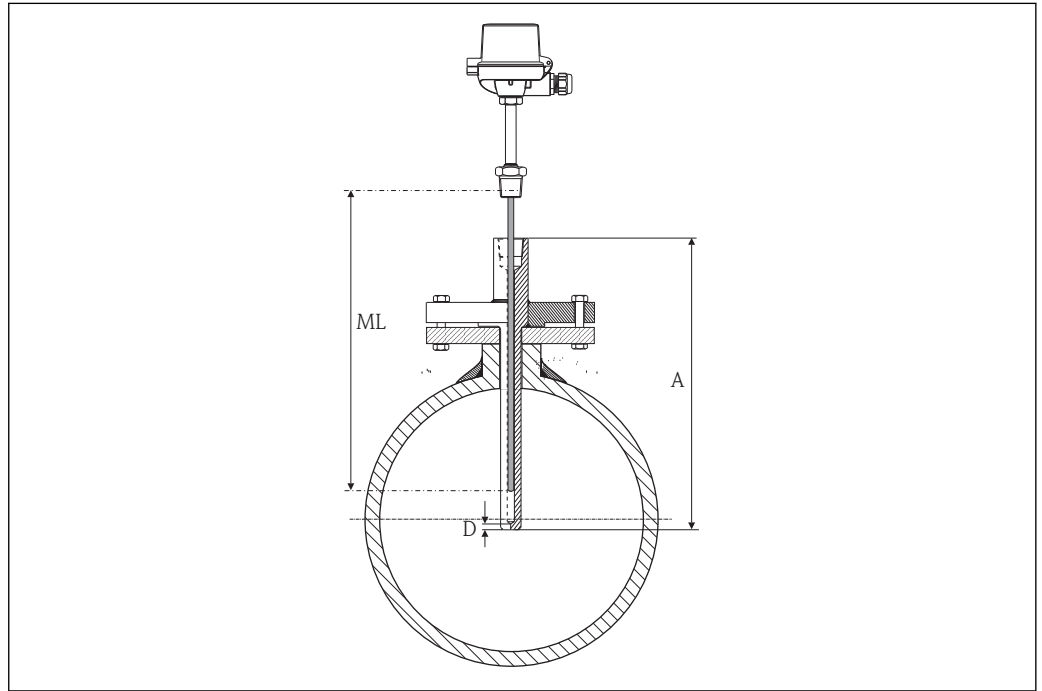

4 Thermometer installation

The thermometer is designed for installation in an existing thermowell or in a thermowell which can be ordered separately. Different threaded connections to suit the thermowell are available on the thermometer's extension neck (→ 14). The necessary insertion length (ML) of the insert depends on the total length of the thermowell (A) and the type of thermowell used. It can be freely selected within the range of 100 to 5 000 mm (3.94 to 197 in). Longer insertion lengths are available on request. This also applies when ordering the insert as a spare part. More detailed information on determining the insertion length (ML) required in each case can be found in the following table (applies to Endress+Hauser thermowells with standard base thicknesses (D)).

Type of thermowell	ML in mm (in)	Type of thermowell	ML in mm (in)
TA535	ML = A	TA565	ML = A - 3 (0.12)
TA540	ML = A - 2 (0.08)	TA566	ML = A - 3 (0.12)
TA550	ML = A - 3 (0.12)	TA570	ML = A - 3 (0.12)
TA555	ML = A - 2 (0.08)	TA571	ML = A - 3 (0.12)
TA557	ML = A - 2 (0.08)	TA572	ML = A - 3 (0.12)
TW15	ML = A	TA575	ML = A - 3 (0.12)
TA560	ML = A - 3 (0.12)	TA576	ML = A - 2 (0.08)
TA562	ML = A - 3 (0.12)		

In the case of thermowells with a noncompliant standard base thickness (D), the following formula must be used: **ML = A - D + 3 (0.12)** in mm (in).

**Extension neck length**

The extension neck is the part between the process connection and the terminal head. As illustrated in the following diagram, the extension neck length influences the temperature in the terminal head. This temperature must remain within the limit values defined in the "Operating conditions" section.

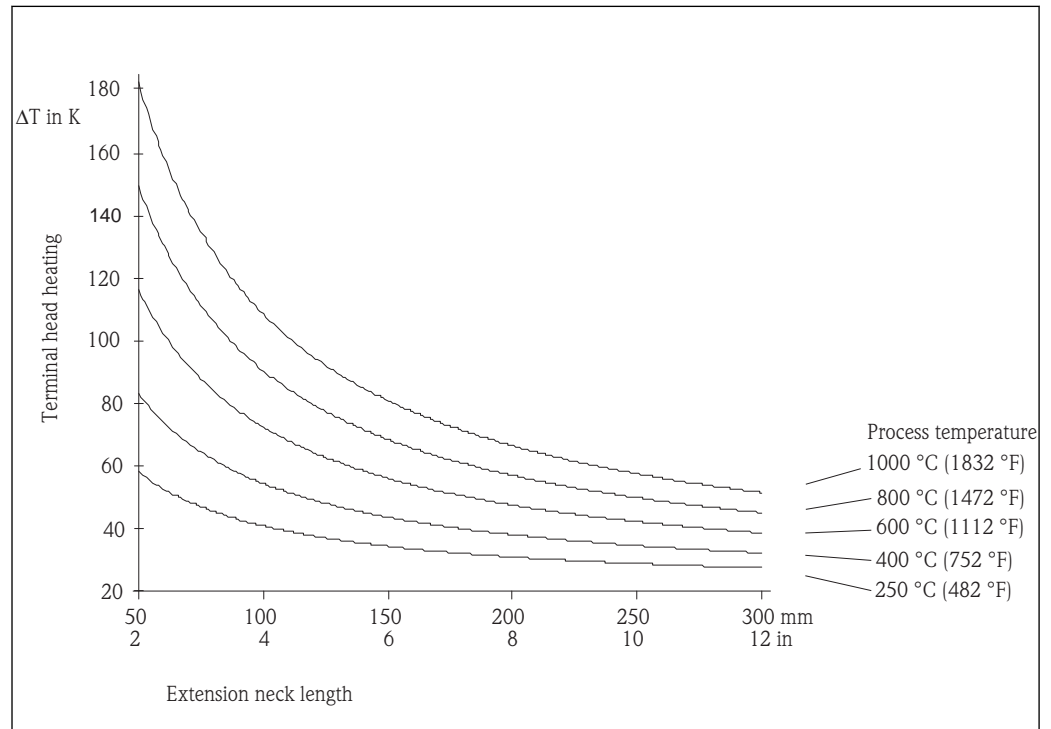

A0012701-EN

- 5 Heating of the terminal head as a function of the process temperature. Temperature in terminal head = ambient temperature 20 °C (68 °F) +  $\Delta T$

## Certificates and approvals

<b>CE Mark</b>	The device meets the legal requirements of the EC directives if applicable. Endress+Hauser confirms that the device has been successfully tested by applying the CE mark.
<b>Hazardous area approvals</b>	For further details on the available Ex versions (ATEX, CSA, FM etc.), please contact your nearest Endress +Hauser sales organization. All relevant data for hazardous areas can be found in separate Ex documentation.
<b>Other standards and guidelines</b>	<ul style="list-style-type: none"><li>■ EN 60079: ATEX certification for hazardous areas</li><li>■ IEC 60529: Degree of protection of housing (IP code)</li><li>■ IEC 61010-1: Protection Measures for Electrical Equipment for Measurement, Control, Regulation and Laboratory Procedures.</li><li>■ IEC 60751: Industrial platinum resistance thermometers</li><li>■ IEC 60584 and ASTM E230/ANSI MC96.1: Thermocouples</li><li>■ DIN EN 50446: Terminal heads</li><li>■ IEC 61326-1: Electromagnetic compatibility (EMC requirements)</li></ul>
<b>PED approval</b>	The thermometer complies with paragraph 3.3 of the Pressure Equipment Directive 97/23/CE and is not marked separately.
<b>Test report and calibration</b>	The "Factory calibration" is carried out according to an internal procedure in a laboratory of Endress+Hauser accredited by the European Accreditation Organization (EA) according to ISO/IEC 17025. A calibration which is performed according to EA guidelines (SIT/Accredia or DKD/DAKks calibration) may be requested separately. The calibration is performed on the replaceable insert of the thermometer. In the case of thermometers without a replaceable insert, the entire thermometer - from the process connection to the tip of the thermometer - is calibrated.

## Ordering information

Detailed ordering information is available from the following sources:

- In the Product Configurator on the Endress+Hauser website: [www.endress.com](http://www.endress.com) → Select country → Instruments → Select device → Product page function: Configure this product
- From your Endress+Hauser Sales Center: [www.endress.com/worldwide](http://www.endress.com/worldwide)









### Product Configurator - the tool for individual product configuration

- Up-to-the-minute configuration data
- Depending on the device: Direct input of measuring point-specific information such as measuring range or operating language
- Automatic verification of exclusion criteria
- Automatic creation of the order code and its breakdown in PDF or Excel output format
- Ability to order directly in the Endress+Hauser Online Shop

## Accessories

Various accessories, which can be ordered with the device or subsequently from Endress+Hauser, are available for the device. Detailed information on the order code in question is available from your local Endress+Hauser sales center or on the product page of the Endress+Hauser website: [www.endress.com](http://www.endress.com).



Communication-specific accessories		
Configuration kit TXU10	Configuration kit for PC-programmable transmitter with setup software and interface cable for PC with USB port Order code: TXU10-xx	
Commubox FXA195 HART	For intrinsically safe HART communication with FieldCare via the USB interface.  For details, see "Technical Information" TI00404F	
Commubox FXA291	Connects Endress+Hauser field devices with a CDI interface (= Endress+Hauser Common Data Interface) and the USB port of a computer or laptop.  For details, see "Technical Information" TI00405C	
HART Loop Converter HMX50	Is used to evaluate and convert dynamic HART process variables to analog current signals or limit values.  For details, see "Technical Information" TI00429F and Operating Instructions BA00371F	
Wireless HART adapter SWA70	Is used for the wireless connection of field devices. The WirelessHART adapter can be easily integrated into field devices and existing infrastructures, offers data protection and transmission safety and can be operated in parallel with other wireless networks with minimum cabling complexity.  For details, see Operating Instructions BA061S	
Fieldgate FXA320	Gateway for the remote monitoring of connected 4-20 mA measuring devices via a Web browser.  For details, see "Technical Information" TI00025S and Operating Instructions BA00053S	
Fieldgate FXA520	Gateway for the remote diagnostics and remote configuration of connected HART measuring devices via a Web browser.  For details, see "Technical Information" TI00025S and Operating Instructions BA00051S	
Field Xpert SFX100	Compact, flexible and robust industry handheld terminal for remote configuration and for obtaining measured values via the HART current output (4-20 mA).  For details, see Operating Instructions BA00060S	

### Service-specific accessories

Accessories	Description
Applicator	<p>Software for selecting and sizing Endress+Hauser measuring devices:</p> <ul style="list-style-type: none"> <li>■ Calculation of all the necessary data for identifying the optimum measuring device: e.g. pressure loss, accuracy or process connections.</li> <li>■ Graphic illustration of the calculation results</li> </ul> <p>Administration, documentation and access to all project-related data and parameters over the entire life cycle of a project.</p> <p>Applicator is available:</p> <ul style="list-style-type: none"> <li>■ Via the Internet: <a href="https://wapps.endress.com/applicator">https://wapps.endress.com/applicator</a></li> <li>■ On CD-ROM for local PC installation.</li> </ul>

Konfigurator <sup>+</sup> temperature	<p>Software for selecting and configuring the product depending on the measuring task, supported by graphics. Includes a comprehensive knowledge database and calculation tools:</p> <ul style="list-style-type: none"> <li>■ For temperature competence</li> <li>■ Quick and easy design and sizing of temperature measuring points</li> <li>■ Ideal measuring point design and sizing to suit the processes and needs of a wide range of industries</li> </ul> <p>The Konfigurator is available: On request from your Endress+Hauser sales office on a CD-ROM for local PC installation.</p>
W@M	<p>Life cycle management for your plant W@M supports you with a wide range of software applications over the entire process: from planning and procurement, to the installation, commissioning and operation of the measuring devices. All the relevant device information, such as the device status, spare parts and device-specific documentation, is available for every device over the entire life cycle.</p> <p>The application already contains the data of your Endress+Hauser device. Endress +Hauser also takes care of maintaining and updating the data records.</p> <p>W@M is available:</p> <ul style="list-style-type: none"> <li>■ Via the Internet: <a href="http://www.endress.com/lifecyclemanagement">www.endress.com/lifecyclemanagement</a></li> <li>■ On CD-ROM for local PC installation.</li> </ul>
FieldCare	<p>FDT-based plant asset management tool from Endress+Hauser. It can configure all smart field units in your system and helps you manage them. By using the status information, it is also a simple but effective way of checking their status and condition.</p> <p> For details, see Operating Instructions BA00027S and BA00059S</p>

**System components**

Accessories	Description
Field display unit RIA16	<p>The display unit records the analog measuring signal from the head transmitter and shows this on the display. The LC display shows the current measured value in digital form and as a bar graph indicating a limit value violation. The display unit is looped into the 4 to 20 mA circuit and gets the required energy from there.</p> <p> For details, see the "Technical Information" document TI00144R/09/en</p>
RN221N	<p>Active barrier with power supply for safe separation of 4-20 mA standard signal circuits. Offers bidirectional HART transmission.</p> <p> For details, see "Technical Information" TI00073R and Operating Instructions BA00202R</p>
RNS221	<p>Supply unit for powering two 2-wire measuring devices solely in the non-Ex area. Bidirectional communication is possible via the HART communication jacks.</p> <p> For details, see "Technical Information" TI00081R and Brief Operating Instructions KA00110R</p>

## Documentation

### Technical Information:

- iTEMP® Temperature head transmitter:
  - TMT180, PC-programmable, single-channel, Pt100 (TI088R/09/en)
  - PCP TMT181, PC-programmable, single-channel, RTD, TC, Ω, mV (TI00070R/09/en)
  - HART® TMT182, single-channel, RTD, TC, Ω, mV (TI078R/09/en)
  - HART® TMT82, two-channel, RTD, TC, Ω, mV (TI01010T/09/en)
  - PROFIBUS® PA TMT84, two-channel, RTD, TC, Ω, mV (TI138R/09/en)
  - FOUNDATION Fieldbus™ TMT85, two-channel, RTD, TC, Ω, mV (TI134R/09/en)
- Inserts:
  - Resistance thermometer insert Omniset TPR100 (TI268t/02/en)
  - Thermocouple insert Omniset TPC100 (TI278t/02/en)
  - iTHERM® TS111 Insert for installation in thermometers (TI01014T/09/en)
- Application example:
  - RN221N Active barrier, for supplying loop-powered transmitters (TI073R/09/en)
  - RIA16 Field display unit, loop-powered (TI00144R/09/en)

Technical information thermowells:

Schutzrohrtyp			
TA535	TI250T/02/en	TA565	TI160T/02/en
TA540	TI00166T/09/en	TA566	TI177T/02/en
TA550	TI153T/02/en	TA570	TI161T/02/en
TA555	TI154T/02/en	TA571	TI178T/02/en
TA557	TI156T/02/en	TA572	TI179T/02/en
TW15	TI00265T/02/en	TA575	TI162T/02/en
TA560	TI159T/02/en	TA576	TI163T/02/en
TA562	TI00230T/09/en		

### Supplementary ATEX documentation:

- Omnigrad TRxx, TCxx, TSTxxx, TxCxxx; Omniset TPR100, TET10x, TPC100, TEC10x, iTHERM® TS111 ATEX II 3GD Ex nA (XA00044R/09/a3)
- RTD/TC Thermometer Omnigrad TRxx, TCxx, TxCxxx, ATEX II 1GD or II 1/2GD Ex ia IIC T6...T1 (XA00072R/09/a3)
- Inserts Omniset TPR100, TPC100, ATEX II 1G (XA087R/09/a3)
- iTHERM® TS111, TM211 Omnigrad TST310, TSC310 Omniset TPR100, TPC100 IECEx Ex ia IIC T6...T1 (XA00100R/09/a3)

---

## Instruments International

Endress+Hauser  
Instruments International AG  
Kaegenstrasse 2  
4153 Reinach  
Switzerland

Tel.+41 61 715 81 00  
Fax+41 61 715 25 00  
[www.endress.com](http://www.endress.com)  
[info@ii.endress.com](mailto:info@ii.endress.com)

**Endress+Hauser**   
People for Process Automation