



Dial Thermometers - TG 100

- Used where industrial accuracy is needed.
- Used with gas and liquids which do not attack stainless steel 316L.
- With its capillary tubing Thermometer's body can be mounted away from heat source (max. 5mt)
- In vibrating environments silicon oil filled types should be used.
- As an option electric contacts can be added on request.

Industry Sector: Petro-chemical plants, Machinery Manufacturing, Heating, ventilation, & conditioning (HVAC) and vessel manufacturers



Usage Properties

Conformity	· EN 13190
Accuracy Class	· CL 1.0
Protection Rate	· IP 51
Storage Temperature	· -40 ... +70 °C

Constructive Properties

Mounting Type	· Bottom Connection
Scale Range (T)	· -40/+40°C · -40/+60°C · 0/+120°C · 0/+160°C · · · 0/+300°C · 0/+350°C · 0/+400°C · 0/+500°C
Case	· Stainless Steel AISI-304
Bezel	· Stainless Steel AISI-304
Window	· Glass
Connection	· G 1/2" B
Dial	· Aluminum
Pointer	· Aluminum
Temperature Element	· Gas Actuated
Thermowell	· Stainless Steel AISI-316L
Immersion Length	· 200mm
Capillary Tube Length	· 3m · 5m

Technical Drawings - TG 100

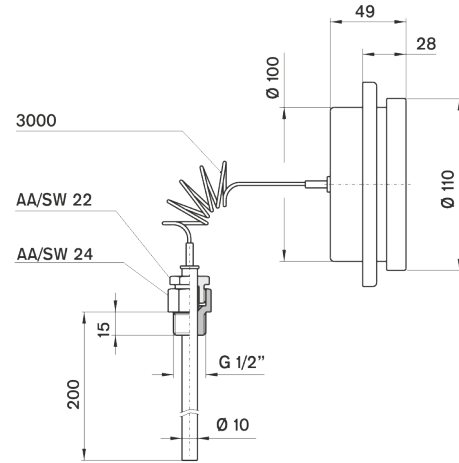
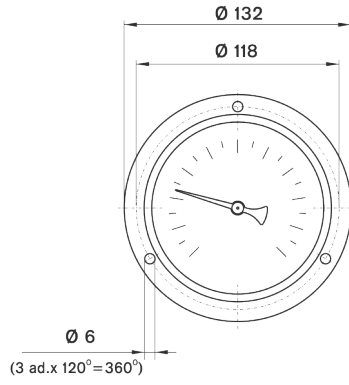

100 612 /

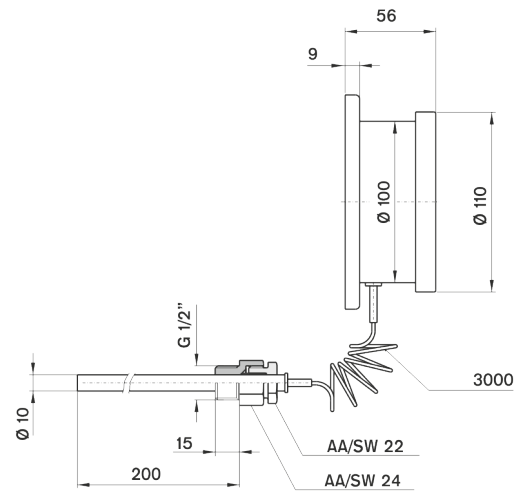
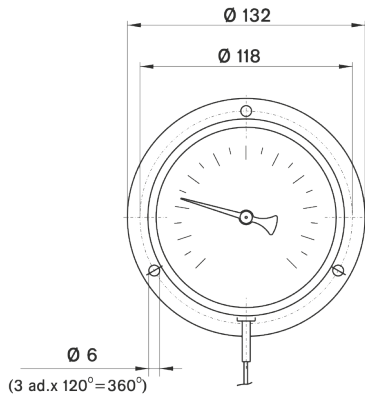

100 611 /