

# Process transmitter

## With welded metal measuring cell

### Models IPT-20, IPT-21

WIKA data sheet PE 86.06



for further approvals  
see page Seite 11



## Applications

- Chemical and petrochemical industries
- Process engineering
- Pharmaceutical industry
- Food and beverage industry
- Hazardous areas

## Special features

- Ex protection per ATEX and IECEx
- For applications to SIL 2 (SIL 3)
- Welded metal measuring cell
- Seven different case variants
- Configuration via EDD and DTM (Device Type Manager) in accordance with the FDT (Field Device Tool) concept, e.g. PACTware



**Fig. left: Model IPT-20, with pressure port**  
**Fig. right: Model IPT-21, with flush diaphragm**

## Description

With its 4 ... 20 mA, 4 ... 20 mA HART®, PROFIBUS® PA or FOUNDATION Fieldbus™ output signals, combined with either intrinsic safety or flameproof enclosure ignition protection type (in accordance with ATEX and IECEx), the model IPT-2x is ideally suited to applications with the highest demands on the measurement technology.

### Versatile in application

As a result of the available measuring ranges of 0 ... 0.1 bar to 0 ... 4,000 bar [0 ... 0.15 to 0 ... 60,000 psi] and a freely-selectable turndown, the instrument can be used in almost any application. The large number of process connections and the extensive possibilities offered by the metal measuring cell enables use in all industries.

There are seven different case variants available, and thus it is possible to select a variant suited to every operating environment.

The case itself can be rotated through 330° and is available in plastic, aluminium and stainless steel.

An electropolished stainless steel case (316L) is available to meet the high demands of the food and pharmaceutical industries.

### Easy configuration and operation

Service and configuration at the instrument is carried out using the optional display and operating module, which can be fitted in four positions. The operating menu has a simple and self-explanatory structure and has nine selectable languages as standard. Alternatively, the operating parameters can be set using the PACTware™ free and non-proprietary configuration software. An instrument-specific DTM enables easy integration into corresponding process control systems.

# Specifications

## Instrument versions and measuring cells

Version	Measuring cell
Standard version	Metal measuring cell with piezoresistive sensor or thin-film sensor (depending on measuring range)
Version with cooling element (extended medium temperature range)	Metal measuring cell with piezoresistive sensor or thin-film sensor (depending on measuring range)
High-temperature version	Ceramic/metal measuring cell (→ for medium temperatures up to 200 °C [392 °F], see operating conditions)

## Measuring ranges

Gauge pressure				
bar	0 ... 0.1 <sup>2)</sup>	0 ... 0.4	0 ... 1	0 ... 2.5
	0 ... 5	0 ... 10	0 ... 25	0 ... 40
	0 ... 100	0 ... 250	0 ... 600	0 ... 1,000 <sup>1)</sup>
	0 ... 1,600 <sup>1)</sup>	0 ... 2,500 <sup>1)</sup>	0 ... 4,000 <sup>1)</sup>	
psi	0 ... 1.5 <sup>2)</sup>	0 ... 5	0 ... 15	0 ... 30
	0 ... 75	0 ... 150	0 ... 300	0 ... 500
	0 ... 1,450	0 ... 3,000	0 ... 9,000	0 ... 15,000 <sup>1)</sup>
	0 ... 30,000 <sup>1)</sup>	0 ... 50,000 <sup>1)</sup>	0 ... 60,000 <sup>1)</sup>	

Absolute pressure				
bar	0 ... 0.1 <sup>2)</sup>	0 ... 0.4 <sup>2)</sup>	0 ... 1	0 ... 2.5
	0 ... 5	0 ... 10	0 ... 25	0 ... 40
psi	0 ... 1.5	0 ... 5	0 ... 15	0 ... 30
	0 ... 150	0 ... 300	0 ... 500	

Vacuum and +/- measuring range				
bar	-0.05 ... +0.05 <sup>2)</sup>	-0.2 ... +0.2	-0.5 ... +0.5	-1 ... 0
	-1 ... +1.5	-1 ... +5	-1 ... +10	-1 ... +25
	-1 ... 40			
psi	-0.7 ... +0.7	-3 ... +3	-7 ... +7	-14.5 ... 0
	-14.5 ... +20	-14.5 ... +75	-14.5 ... +150	-14.5 ... +300
	-14.5 ... +500			

1) Only for model IPT-20

2) Only for high-temperature version

Other measuring ranges can be set via turndown (scaling).

Maximum setting range of the pressure value: -20 ... +120 %

For example, a 0 ... 10 bar [0 ... 150 psi] instrument can also be used from -1 ... +10 bar [-14.5 ... +150 psi].

Values of less than 0 bar abs. [0 psia] cannot be set or measured.

Vacuum/overload safety	
Vacuum safety	Yes (not for oxygen applications)
Overload safety (standard version, version with cooling element)	
Measuring range ≤ 40 bar [500 psi]	3 times
Measuring range 40 ... 1,000 bar [500 ... 15,000 psi]	2 times

Vacuum/overload safety	
Measuring range 1,600 bar [30,000 psi]	1.5 times
Measuring range 2,500 bar [50,000 psi]	1.4 times
Measuring range 4,000 bar [60,000 psi]	1.25 times
Overload safety (high-temperature version)	
Measuring range 0.1 bar [1.5 psi]	15 bar [220 psi]
Measuring range 0.4 bar [5 psi]	30 bar [430 psi]
Measuring range 1.0 bar [15 psi]	35 bar [510 psi]
Measuring ranges from 2.5 ... 25 bar [30 ... 300 psi]	50 bar [720 psi]

## Output signals

Output signals	
<b>Signal types</b>	<ul style="list-style-type: none"> <li>■ 4 ... 20 mA</li> <li>■ 4 ... 20 mA with a superimposed HART® communication signal (option: SIL qualification)</li> <li>■ HART® specification: 7.3</li> <li>■ FOUNDATION™ Fieldbus</li> <li>■ PROFIBUS® PA</li> <li>■ Slave electronics for electrical differential pressure (option: SIL qualification)</li> </ul>
<b>Load in <math>\Omega</math></b>	$(U_B - U_{Bmin}) / 0.022 \text{ A}$ $U_B$ = Applied supply voltage (→ see table "Supply voltage") $U_{Bmin}$ = Minimum supply voltage (→ see table "Supply voltage")
<b>Dampening</b>	0 ... 999 s, adjustable After the set dampening time the instrument outputs 63 % of the applied pressure as output signal. Example: A pressure impulse increases from 0 to 10 bar with a dampening of 2 seconds. After the 2 seconds a pressure of 6.3 bar is displayed.
<b>Step response time</b>	< 80 ms (= dead time < 25 ms + rise time 10 ... 90 % < 55 ms)

## Accuracy specifications

Accuracy specifications		
<b>Accuracy at room temperature <sup>1)</sup></b>		
Measuring range $\leq$ 1,000 bar [15,000 psi]	0.1 % of span (options: 0.075 % / 0.2 %)	
Measuring range > 1,000 bar [15,000 psi]	0.5 % of span	
<b>Adjustability</b>		
Zero point	-20 ... +95 % (downwards, the adjustability is always limited by the minimum pressure of 0 bar abs.)	
Span	Measuring range $\leq$ 1,000 bar [15,000 psi]	-120 ... +120 % with a difference between zero point and span of max. 120 % of the nominal measuring range
	Measuring range > 1,000 bar [15,000 psi]	(0 bar abs.) ... +105 % (downwards, the adjustability is always limited by the minimum pressure of 0 bar abs.)
Turndown	Unlimited	
	Measuring range $\leq$ 1,000 bar [15,000 psi]	Maximum recommended turndown 20:1
	Measuring range > 1,000 bar [15,000 psi]	Maximum recommended turndown 2:1
	SIL applications	Max. turndown 10:1
<b>Non-linearity per BFSL (per IEC 61298-2)</b>		
Measuring range $\leq$ 1,000 bar [15,000 psi]	$\leq$ 0.05 % of span	
Measuring range > 1,000 bar [15,000 psi]	$\leq$ 0.25 % of span	

Accuracy specifications		
<b>Non-repeatability (per IEC 61298-2)</b>		
Measuring range ≤ 1,000 bar [15,000 psi]	≤ 0.1 % of span	
Measuring range > 1,000 bar [15,000 psi]	≤ 0.5 % of span	
<b>Behaviour with turndown</b>		
1:1 ... 5:1 with measuring range 0.1 ... 1,000 bar [1.5 ... 15,000 psi]	No change in accuracy	
> 5:1 with measuring range 0.1 ... 1,000 bar [1.5 ... 15,000 psi]	(basic accuracy / 5) x turndown	
1:1 ... 2:1 with measuring range > 1,000 bar [15,000 psi]	< 0.5 % x turndown	
<b>Long-term stability at reference conditions (standard version, version with cooling element)</b>		
Measuring range < 1 bar [15 psi]	≤ (0.35 % x turndown) / year	
Measuring range = 1 bar [15 psi]	≤ (0.15 % x turndown) / year	
Measuring range > 1 bar [15 psi]	≤ (0.10 % x turndown) / year	
Measuring range > 1,000 bar [15,000 psi]	≤ (0.50 % x turndown) / year	
<b>Long-term stability at reference conditions (high-temperature version)</b>	≤ (0.05 % x turndown) / year	
<b>Thermal change, zero point and span (reference temperature 20 °C [68 °F])</b>		
In compensated range 10 ... 70 °C [50 ... 158 °F]	Measuring range ≤ 1,000 bar [15,000 psi]	< 0.075 % / 10 K (max. 0.15 %)
	Measuring range > 1,000 bar [15,000 psi]	No compensated range
Outside compensated range	Measuring range ≤ 1,000 bar [15,000 psi]	< 0.15 % + 0.075 % / 10 K
	Measuring range > 1,000 bar [15,000 psi]	< 0.5 % + 0.2 % / 10 K
<b>Thermal change of the current output (reference temperature 20 °C [68 °F])</b>	< 0.05 % / 10 K (max. 0.15 %) for 4 ... 20 mA output at -40 ... +80 °C [-40 ... +176 °F]	
<b>Deviations through strong electromagnetic fields within the scope of EN 61326-1</b>	< ±150 µA	

1) Including non-linearity, hysteresis, zero offset and end value deviation (corresponds to measured error per IEC 61298-2). Calibrated in vertical mounting position with process connection facing downwards.

For use in hydrogen applications, observe the Technical information IN 00.40 at [www.wika.com](http://www.wika.com) regarding long-term stability.

## Reference conditions (per IEC 61298-1)

Reference conditions (per IEC 61298-1)	
<b>Temperature</b>	18 ... 30 °C [64 ... 86 °F]
<b>Atmospheric pressure</b>	860 ... 1,060 mbar [86 ... 106 kPa, 12.5 ... 15.4 psig]
<b>Air humidity</b>	45 ... 75 % r. h.
<b>Characteristic curve determination</b>	Terminal method per IEC 61298-2
<b>Curve characteristics</b>	Linear
<b>Reference mounting position</b>	Vertical, diaphragm points downward

## Voltage supply

### Supply voltage (non-Ex and Ex d)

Signal type	Backlighting	
	Inactive	Active
4 ... 20 mA	DC 9.6 ... 35 V	DC 16 ... 35 V
4 ... 20 mA with a superimposed HART® communication signal	DC 9.6 ... 35 V	DC 16 ... 35 V
FOUNDATION™ Fieldbus	DC 9 ... 32 V	DC 13.5 ... 32 V
PROFIBUS® PA	DC 9 ... 32 V	DC 13.5 ... 32 V

### Supply voltage (Ex ia)

Signal type	Backlighting	
	Inactive	Active
4 ... 20 mA	DC 9.6 ... 30 V	DC 16 ... 30 V
4 ... 20 mA with a superimposed HART® communication signal	DC 9.6 ... 30 V	DC 16 ... 30 V
FOUNDATION™ Fieldbus	DC 9 ... 24 V (DC 9 ... 17.5 V Fisco)	DC 13.5 ... 24 V (DC 13.5 ... 17.5 V Fisco)
PROFIBUS® PA	DC 9 ... 24 V (DC 9 ... 17.5 V Fisco)	DC 13.5 ... 24 V (DC 13.5 ... 17.5 V Fisco)

## Process connections

### Standard process connections for model IPT-20

EN 837	<ul style="list-style-type: none"> <li>■ G ½ B</li> <li>■ M20 x 1.5</li> <li>■ G ¼ B female, G ½ B male (for high-temperature version with metal/ceramic measuring cell)</li> </ul>
ANSI / ASME B1.20.1	<ul style="list-style-type: none"> <li>■ ½ NPT</li> <li>■ ½ NPT female</li> <li>■ ¼ NPT female, ½ NPT male</li> </ul>

### Standard high-pressure connections for model IPT-20 from 1,600 bar [30,000 psi]

-	<ul style="list-style-type: none"> <li>■ M16 x 1.5 female</li> <li>■ M20 x 1.5 female</li> <li>■ 9/16-18 UNF female</li> <li>■ 1 ½ -12 UNF female thread</li> </ul>
---	---

### Aseptic process connections for model IPT-21

Flush	<ul style="list-style-type: none"> <li>■ G ½ B</li> <li>■ G 1 B</li> <li>■ G 1 ½ B</li> <li>■ G 1 hygienic</li> </ul>
ANSI / ASME B1.20.1	½ NPT (for high-temperature version)
-	<ul style="list-style-type: none"> <li>■ M44 x 1.25 with union nut (for version with cooling element)</li> <li>■ M44 x 1.25 with union nut (for high-temperature version)</li> </ul>
TRI-CLAMP®	<ul style="list-style-type: none"> <li>■ 1 ½"</li> <li>■ 2"</li> </ul>
VARINLINE®	<ul style="list-style-type: none"> <li>■ Form F</li> <li>■ Form N</li> </ul>
Grooved union nut DIN 11851	<ul style="list-style-type: none"> <li>■ DN 25</li> <li>■ DN 40</li> <li>■ DN 50</li> </ul>

Aseptic process connections for model IPT-21	
NEUMO BioControl®	<ul style="list-style-type: none"> <li>■ Size 50</li> <li>■ Size 65</li> </ul>
Clamp connection per DIN 11864-3	<ul style="list-style-type: none"> <li>■ DN 40</li> <li>■ DN 50</li> </ul>

BioControl® is a registered trademark of NEUMO.

Pressure transmission medium		
Standard version and extended medium temperature range		
Model IPT-20	Measuring range ≤ 40 bar [500 psi]	Synthetic oil, halocarbon oil
	Measuring range > 40 bar [500 psi]	Dry measuring cell
Model IPT-21	Synthetic oil, halocarbon oil	
High-temperature version		
Models IPT-20 and IPT-21	Medicinal white mineral oil	

Halocarbon oil, generally with oxygen applications, not with vacuum and absolute pressure < 1 bar abs. The application demands special cleaning processes which ensure oil and grease-free surfaces.

Optionally FDA-listed media for the food industry are available. All media are silicone-free.

### Diaphragm seal

By using diaphragm seals, it is possible to adapt the process transmitter to even the most difficult of conditions in the process industry. Thus, the transmitter can be used at extreme temperatures, and with aggressive, corrosive, heterogeneous, abrasive, highly viscous or toxic media. As a result of the wide variety of aseptic connections (such as clamp, threaded pipe or DIN 11864 aseptic connections) measuring assemblies meet the high demands of sterile process engineering.



## Materials

Materials				
Wetted parts				
Standard version, version with cooling element	Model IPT-20	Measuring ranges ≤ 40 bar [500 psi]: Stainless steel 316L/1.4404		
		Measuring ranges > 40 bar [500 psi]: Stainless steel 316L/1.4404 + Elgiloy 2.4711		
		Measuring ranges > 1,000 bar [15,000 psi]: Stainless steel XM-13/1.4534		
	Model IPT-21	Standard	Stainless steel 316L/1.4404	
		Option	Hastelloy C276/2.4819	
Option		Gold-plated 20 μ		
Option	Gold/rhodium-plated 5 μ/1 μ			
High-temperature version	Model IPT-20, IPT-21	Stainless steel 316L / Hastelloy HC276		
O-ring (only for model IPT-21)	NBR, FKM, EPDM, FFKM, FEPM			

316L stainless steel, corresponds to 1.4404 or 1.4435

316Ti stainless steel, corresponds to 1.4571

Case	Material
Single chamber case, plastic	PBT, polyester
Single chamber case, aluminium	Die-casting AlSi10Mg, powder-coated on PE basis
Single chamber case, cast stainless steel	Stainless steel 316L
Single chamber case, electropolished stainless steel, deep-drawn	Stainless steel 316L
Double chamber case, plastic	PBT, polyester

Case	Material
Double chamber case, aluminium	Die-casting AlSi10Mg, powder-coated on PE basis
Double chamber case, cast stainless steel	Stainless steel 316L

## Electrical connection

Electrical connection		
<b>Spring-loaded terminals</b>	Wire cross-section: Wire or strand: 0.2 ... 2.5 mm <sup>2</sup> (AWG 24 ... 14) Strand with end splice: 0.2 ... 1.5 mm <sup>2</sup> (AWG 24 ... 16)	
<b>Cable glands M20 x 1.5</b>		
Plastic, PA	Sealing	NBR
	Cable diameter	<ul style="list-style-type: none"> <li>■ 5 ... 9 mm [0.2 ... 0.35 in]</li> <li>■ 6 ... 12 mm [0.24 ... 0.47 in]</li> <li>■ 10 ... 14 mm [0.39 ... 0.55 in]</li> </ul>
Brass, nickel-plated	Sealing	NBR
	Cable diameter	9 ... 13 mm [0.35 ... 0.51 in] (for armoured cable)
Stainless steel	Sealing	NBR
	Cable diameter	7 ... 12 mm [0.28 ... 0.47 in]
<b>Cable glands ½ NPT</b>		
Sealed with blind plug		
Plastic, PA	Cable diameter	5 ... 9 mm [0.2 ... 0.35 in]
Brass, nickel-plated	Cable diameter	6 ... 12 mm [0.24 ... 0.47 in]
Brass, nickel-plated	Cable diameter	9 ... 13 mm [0.35 ... 0.51 in] (for armoured cable)
<b>Angular connector DIN 175301-803A with mating connector</b>	Wire cross-section: max. 1.5 mm <sup>2</sup> (AWG 16) Ingress protection: IP65 <sup>1)</sup>	
<b>Circular connector M12 x 1 (4-pin) without mating connector</b>	Ingress protection: IP65 <sup>1)</sup>	
<b>Electrical safety</b>	Reverse polarity protection	

1) The stated ingress protection only applies when plugged in using mating connectors that have the appropriate ingress protection.

### Connection compartment for single chamber case

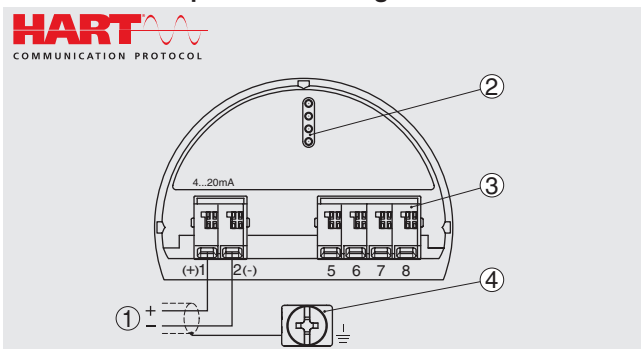

#### 4 ... 20 mA / HART®

①	Voltage supply / signal output
②	Interface of digital display
③	Connection terminals for external display and operating unit
④	Ground terminal for cable shield

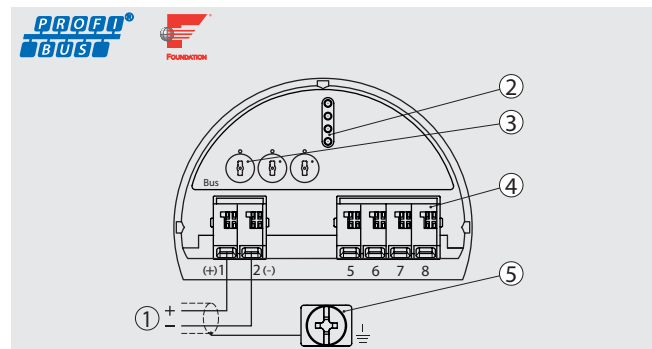

#### PROFIBUS® PA / FOUNDATION™ Fieldbus

①	Voltage supply / signal output
②	Interface of digital display
③	<ul style="list-style-type: none"> <li>■ For FOUNDATION™ Fieldbus simulation switch (1 = operation with simulation release)</li> <li>■ For PROFIBUS® PA: Adjustment of the Profibus settings via 3 switches</li> </ul>
④	Connection terminals for external display and operating unit
⑤	Ground terminal for cable shield

## Differential pressure measurement, master/slave

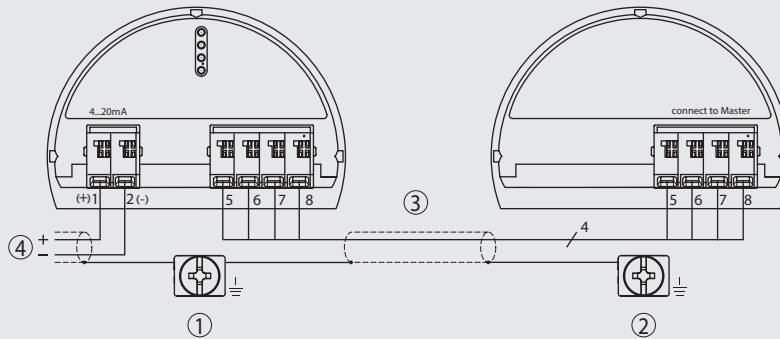

### Master/slave

①	Master
②	Slave
③	Master/slave connection cable, 4-wire (included in delivery) (standard cable length 5 m, maximum cable length 25 m)
④	Voltage supply / signal output (master) (→ see “Voltage supply”)

## Electronic differential pressure measurement with two process transmitters

Two model IPT-2x or CPT-2x process transmitters can be electrically connected into a measuring arrangement in order to be used for electronic differential pressure measurement. The measurement also functions with a combination of both models, though the instruments must both be either absolute pressure or gauge pressure instruments. Another requirement is that one of the instruments is a HART® or BUS-capable instrument that is used as the master and the other is the slave instrument. The instrument must be ordered with this specification in advance.



The process transmitters are connected to each other using an internal BUS cable (→ see figure).

The setting as a master-slave arrangement is made in the master instrument. Thus this instrument takes control of both sensors. As an output signal, the process pressure of the master and the slave, and also the differential pressure are determined.

Electronic differential pressure measurement is used in many applications for detecting the level in tanks and other vessels. Compared to measurement via a differential pressure transmitter and two capillary lines, electronic differential pressure measurement involves bridging the distances between the measuring locations with a current cable. Thus the temperature error of the capillary of a diaphragm seal assembly is completely avoided.

For this measurement procedure, the relation between the static pressure (process pressure) and the differential pressure to be measured is critical. If the static pressure is higher than the differential pressure by a factor of 20, the turndown causes a measurement error that is usually greater than the thermal effect with the same arrangement with capillaries.



## Display and operating unit (option)

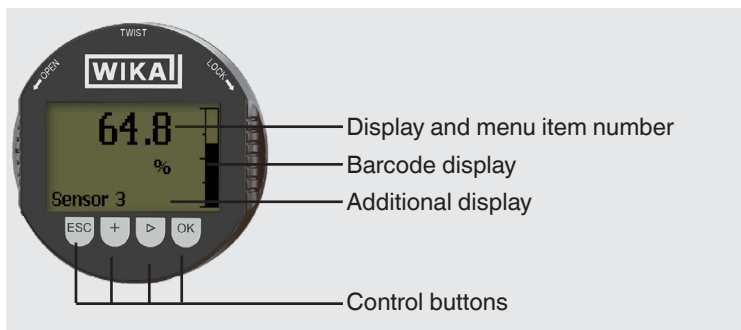

Specifications				
<b>Backlighting</b>	Yes			
<b>Background</b>	Grey, black digits			
<b>Upgradable</b>	Yes (→ For order numbers, see “Accessories”)			
<b>Menu languages</b>	German English French Spanish	Polish Italian Dutch Japanese	Chinese Russian Portuguese Czech	Turkish
Adjustable units				
Pressure units	<ul style="list-style-type: none"> <li>■ bar</li> <li>■ psi</li> <li>■ mbar</li> <li>■ MPa</li> <li>■ kPa</li> </ul>	<ul style="list-style-type: none"> <li>■ Pa</li> <li>■ mmH<sub>2</sub>O</li> <li>■ inH<sub>2</sub>O</li> <li>■ mmHg</li> <li>■ inHg</li> </ul>		
Level units	<ul style="list-style-type: none"> <li>■ m</li> <li>■ cm</li> <li>■ ft</li> <li>■ in</li> </ul>			
<b>Display size</b>	5-digit measured value display, adjustable (option: bar graph display) Max. 5 digits, size 7 x 13 mm [0.28 x 0.51 in]			
<b>Ingress protection per IEC/EN 60529</b>	IP20 (loose) IP40 (built-in without cover)			
<b>Material</b>	Case from ABS, window from polyester film			



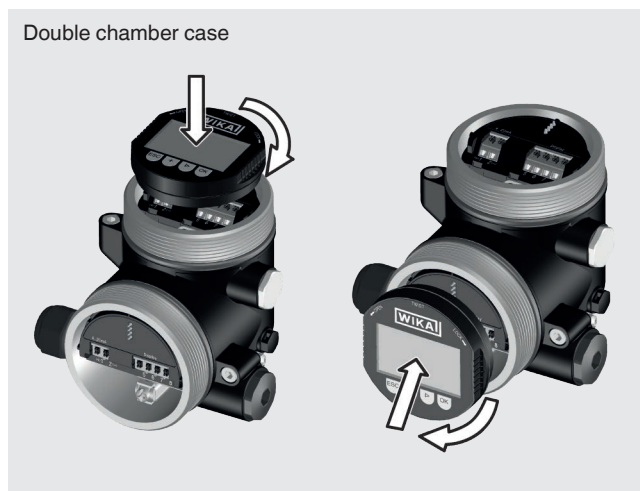
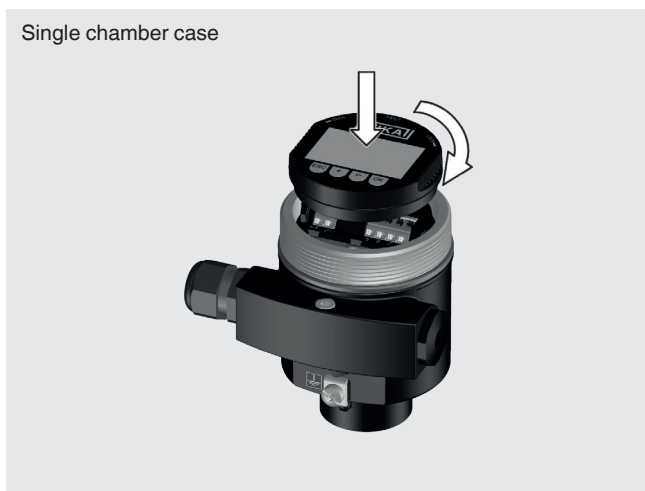



## Mounting positions



## Operating conditions

Operating conditions	
<b>Permissible temperature ranges (standard version, version with cooling element)</b>	
Ambient	<ul style="list-style-type: none"> <li>■ -15 ... +70 °C [5 ... 158 °F] (with digital display)</li> <li>■ -40 ... +80 °C [-40 ... 176 °F] (without digital display)</li> </ul>
Medium	<ul style="list-style-type: none"> <li>■ -40 ... +105 °C [-40 ... 221 °F]</li> <li>■ -20 ... +150 °C [-4 ... 302 °F] (version with cooling element)</li> <li>■ -20 ... +60 °C [-4 ... 140 °F] (for oxygen applications)</li> </ul>
Storage	<ul style="list-style-type: none"> <li>■ -60 ... +80 °C [-76 ... 176 °F] (with digital display)</li> <li>■ -40 ... +80 °C [-40 ... +176 °F] (without digital display)</li> </ul>
<b>Restrictions to medium temperature due to sealing material</b>	For oxygen applications max. 60 °C [140 °F]
FKM	<ul style="list-style-type: none"> <li>■ -20 ... +105 °C (option: -20 ... +150 °C)</li> <li>■ -4 ... +221 °F [option: -4 ... +302 °F]</li> </ul>
EPDM	<ul style="list-style-type: none"> <li>■ -20 ... +105 °C (option: -20 ... +150 °C)</li> <li>■ -4 ... +221 °F [option: -4 ... +302 °F]</li> </ul>
NBR	-15 ... +105 °C [5 ... 221 °F]
FFKM	<ul style="list-style-type: none"> <li>■ -15 ... +105 °C (option -15 ... +150 °C)</li> <li>■ 5 ... 221 °F [option: 5 ... 302 °F]</li> </ul>
FEPM	-5 ... +105 °C [23 ... 221 °F]
<b>Permissible temperature ranges (high-temperature version)</b>	
Ambient	<ul style="list-style-type: none"> <li>■ -12 ... +70 °C [-4 ... 158 °F] (with digital display)</li> <li>■ -12 ... +80 °C [-40 ... 176 °F] (without digital display)</li> </ul>
Medium	<ul style="list-style-type: none"> <li>■ -12 ... +180 °C [-10.4 ... +356 °F]</li> <li>■ -12 ... +200 °C [-10.4 ... +392 °F] (with shield sheet)</li> </ul>
Storage	<ul style="list-style-type: none"> <li>■ -60 ... +80 °C [-76 ... 176 °F] (with digital display)</li> <li>■ -40 ... +80 °C [-40 ... +176 °F] (without digital display)</li> </ul>
<b>Vibration resistance per EN 60068-2-6 (vibration under resonance)</b>	4 g (5 ... 200 Hz) per GL characteristic curve 2 Double chamber case from stainless steel: 0.75 g per GL characteristic curve 1
<b>Shock resistance per IEC 60068-2-27</b>	Measuring range ≤ 1,000 bar [15,000 psi]      50 g (2.3 ms) per IEC 60068-2-27
	Measuring range > 1,000 bar [15,000 psi]      20 g (4.6 ms) per IEC 60068-2-27
	Double chamber case from stainless steel with cooling element      20 g
<b>Instrument safety</b>	
Ingress protection per IEC/EN 60529	<ul style="list-style-type: none"> <li>■ IP66/67</li> <li>■ IP66/IP68 (0.2 bar) for absolute pressure sensors</li> <li>■ Option: IP66/IP68 (1 bar) or IP66/IP68 (25 bar)</li> </ul>
Electrical safety	Overvoltage category III, protection class II
SIL per IEC 61508:2010	Single-channel operation up to SIL 2 Multi-channel operation (homogeneous, redundant) up to SIL 3

## Approvals

Logo	Description	Country
	<b>EU declaration of conformity</b> EMC directive Pressure equipment directive RoHS directive	European Union
	<b>ATEX directive</b> Hazardous areas - Ex i Zone 0 gas [II 1G Ex ia IIC T6 ... T1 Ga] Zone 1 gas mounting to zone 0 gas [II 1/2G Ex ia IIC T6 ... T1 Ga/Gb] Zone 1 gas [II 2G Ex ia IIC T6 ... T1 Gb] Zone 20 dust [II 1D Ex ia IIC T135 Da] Zone 21 dust [II 2D Ex ia IIC T135 Db]  - Ex d Zone 1 gas mounting to zone 0 gas [II 1/2G Ex db ia IIC T6 ... T1 Ga/Gb] Zone 2 gas [II 2G Ex db ia IIC T6 ... T1 Gb] Zone 21 dust [II 2D Ex db ia IIC T135 Db]	
	<b>IECEX</b> Hazardous areas - Ex i Zone 0 gas [Ex ia IIC T6 ... T1 Ga] Zone 1 gas mounting to zone 0 gas [Ex ia IIC T6 ... T1 Ga/Gb] Zone 1 gas [Ex ia IIC T6 ... T1 Gb] Zone 20 dust [Ex ia IIC T135 Da] Zone 21 dust [Ex ia IIC T135 Db]  - Ex d Zone 1 gas mounting to zone 0 gas [Ex db ia IIC T6 ... T1 Ga/Gb] Zone 2 gas [Ex db ia IIC T6 ... T1 Gb] Zone 21 dust [Ex db ia IIC T135 Db]	International
	<b>GOST</b> Metrology, measurement technology	Russia
	<b>UkrSEPRO</b> Metrology, measurement technology	Ukraine
	<b>3-A</b> Food  This instrument is 3-A marked, based on a third party verification for conformance to the 3-A standard.	International
	<b>EHEDG</b> Hygienic Equipment Design	European Union

→ Approvals and certificates, see website

## Manufacturer's information and certificates

Logo	Description
	<b>SIL 2 (option) <sup>1)</sup></b> Functional safety <ul style="list-style-type: none"> <li>■ Single-channel operation up to SIL 2</li> <li>■ Multi-channel operation (homogeneous, redundant) up to SIL 3</li> </ul>
-	<b>NAMUR recommendations</b> NE21 - Electrical compatibility of equipment NE43 - Signal level for failure information NE53 - Compatibility of field instruments NE107 - Self-monitoring and diagnostics

1) Only for output signal 4 ... 20 mA with HART® and with SIL  
Max. turndown for SIL applications 10:1

### **NAMUR recommendations**

NAMUR is the automation technology interest group for the process industry in Germany. The published NAMUR recommendations are considered standards in field instrumentation, and also have the character of international standards.

The instrument fulfils the requirements of the following NAMUR recommendations:

- NE21 - Electromagnetic compatibility of equipment
- NE43 - Signal level for failure information for transmitters
- NE53 - Compatibility of field instruments and display and operating components
- NE107 - Self-monitoring and diagnostics of field instruments

→ For further information, see [www.namur.net/en](http://www.namur.net/en)

### **NACE**

NACE is a term for an organisation (National Association of Corrosion Engineers) concerned with the topic of corrosion. The results of this organisation are published as NACE standards and regularly updated.

The instruments and, in particular, the weld seams fulfil:

- NACE MR0103 - Applications in oil refineries
- NACE MR0175 - Oil extraction and processing

### **FDA compliant filling and sealing**

The FDA is the American supervisory authority for the area of "food and drugs", which also controls all goods placed on the market. An important topic is the use of substances that can come into contact with foodstuffs. Stainless steels are generally not critical, but plastics (e.g. sealings) and liquids (e.g. pressure transmission media) for use in food, pharmaceutical and biotechnology applications must be designed in accordance with the requirements of the FDA.

Some of the substances in these instruments are classified as FDA compliant.

## **Certificates (option)**

- Test certificate for the measurement accuracy included in delivery (5 measuring points in the scaled range)
- 2.2 test report
- 3.1 inspection certificate
- Manufacturer's declaration regarding regulation (EC) 1935/2004
- Manufacturer's declaration regarding regulation (EC) 2023/2006 (GMP)
- DKD/DAkkS calibration per IEC 17025

→ Approvals and certificates, see website

## Dimensions in mm [in]

### Standard process connections for model IPT-20

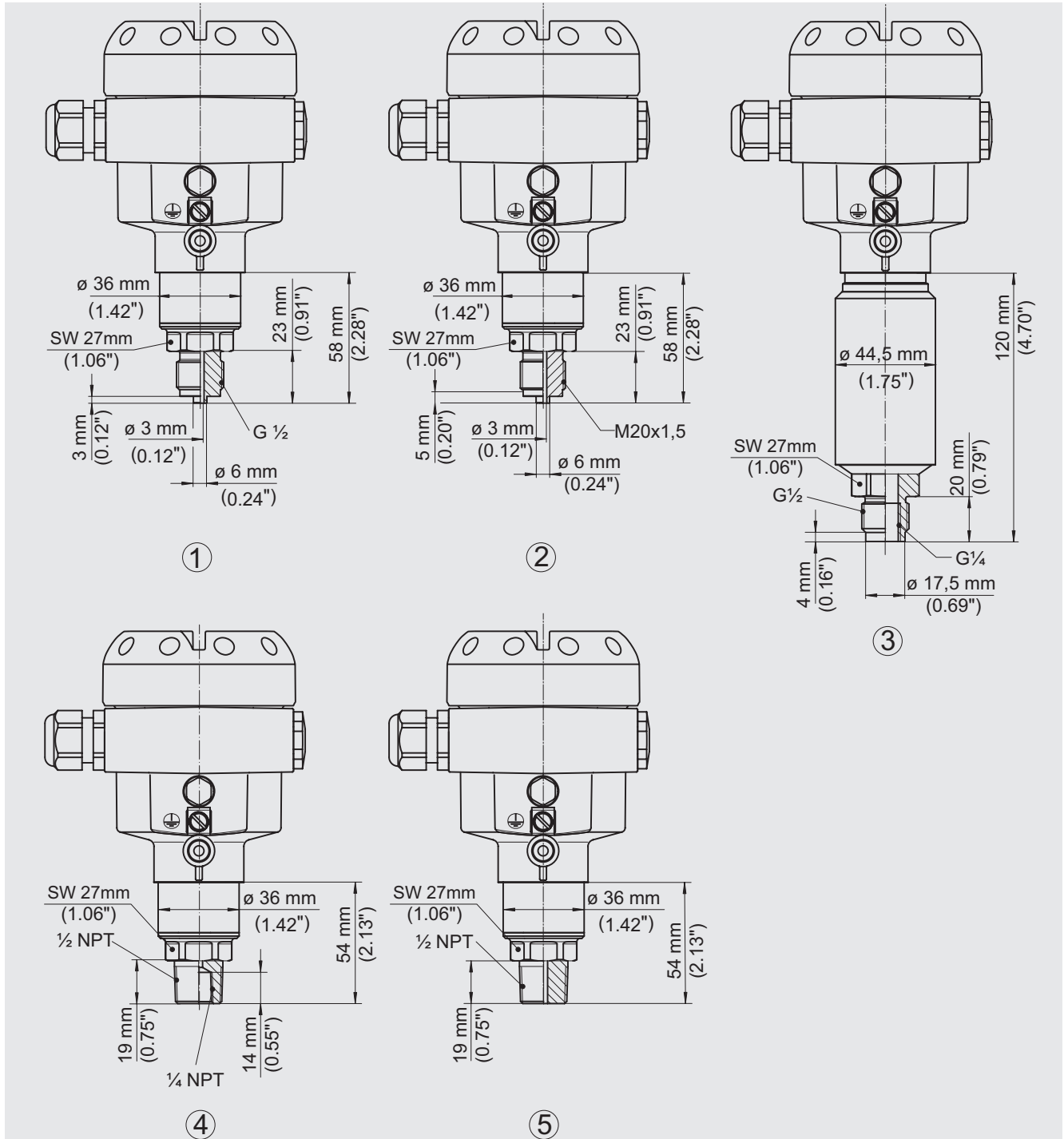

### Standard process connections for model IPT-20

①	EN 837	G 1/2 B
②	DIN 16288	M20 x 1.5
③	ISO 228	G 1/4 B female, G 1/2 B male (for high-temperature version with metal/ceramic measuring cell)
④	ANSI / ASME B1.20.1	1/4 NPT female, 1/2 NPT
⑤	ANSI / ASME B1.20.1	1/2 NPT

## High-pressure process connections for model IPT-20

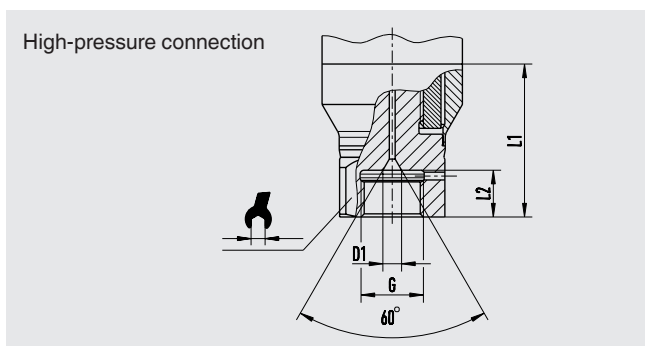

G	L1	D1	SW
M16 x 1.5	12 [0.47]	4.8 [0.19]	27 [1.06]
M20 x 1.5	15 [0.59]	4.8 [0.19]	27 [1.06]

M16 x 1.5 for measuring ranges from 100 bar [1,500 psi] to 4,000 bar [60,000 psi]  
 M20 x 1.5 for measuring ranges from 1,600 bar [30,000 psi] to 4,000 bar [60,000 psi]

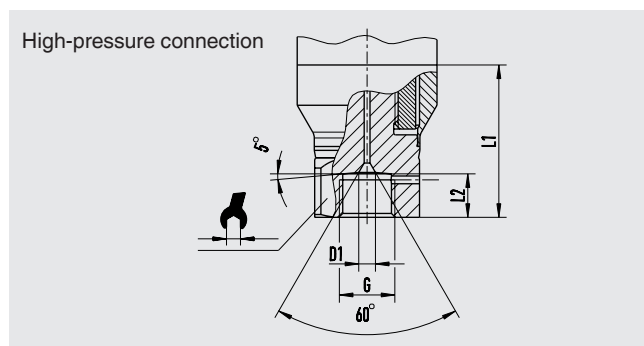

G	L1	D1	SW
9/16-18 UNF female F 250-C	11.2 [0.44]	4.3 [0.17]	27 [1.06]
1 1/8 -12 UNF female F 562-C	19.1 [0.75]	9.7 [0.38]	41 [1.6]

Measuring ranges from 100 bar [1,500 psi] to 4,000 bar [60,000 psi]

Flush process connections for model IPT-21

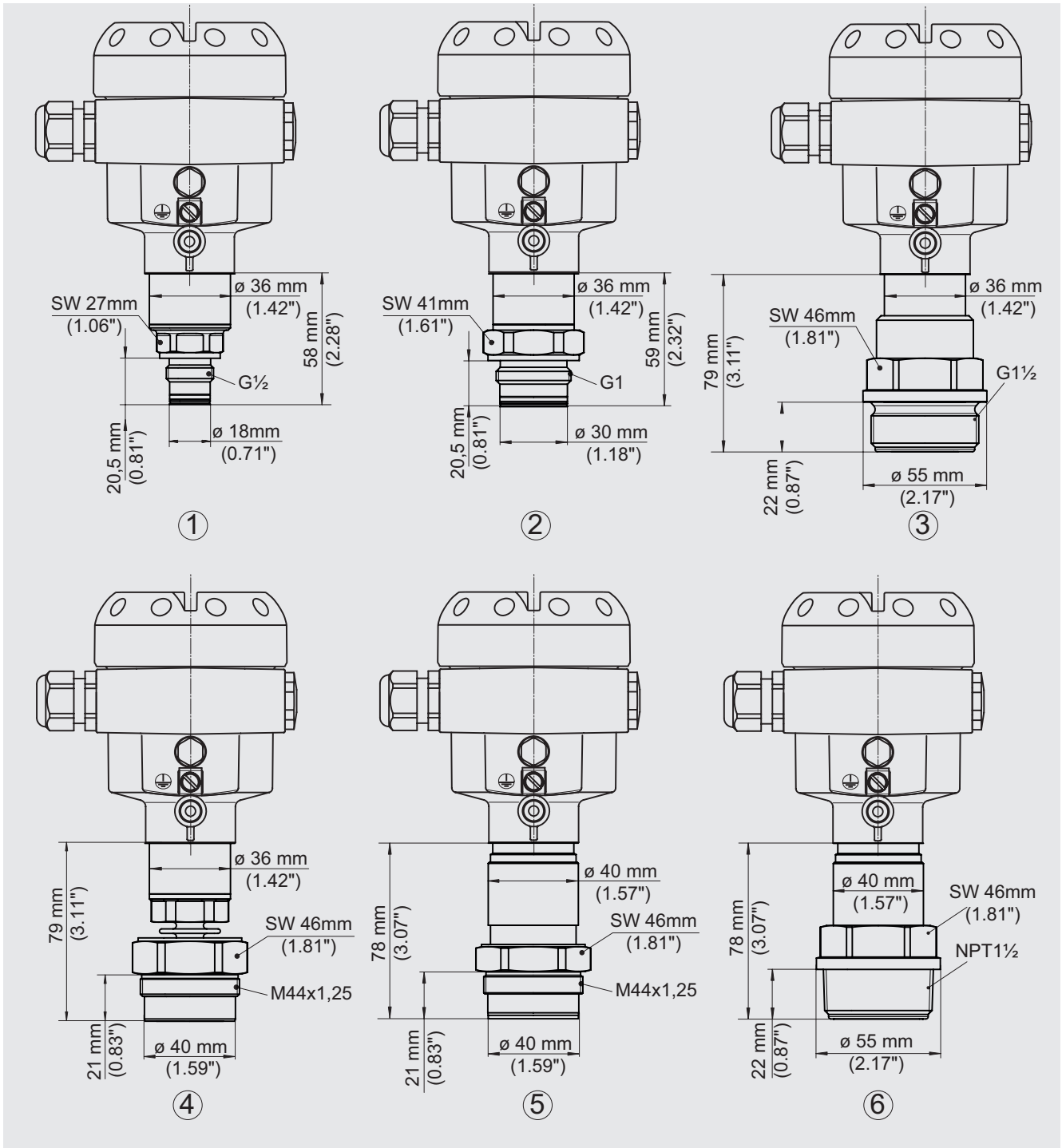

Flush process connections for model IPT-21		
①	EN 837	G ½" B flush with O-ring
②	EN 837	G 1" B flush with O-ring
③	EN 837	G 1 ½" B flush without ring
④	DIN 13	Version with cooling element / Pressure screw: Aluminium
⑤	DIN 13	High-temperature version / Pressure screw: 316L
⑥	ANSI / ASME B1.20.1	1 ½ NPT for high-temperature version

Aseptic process connections for model IPT-21

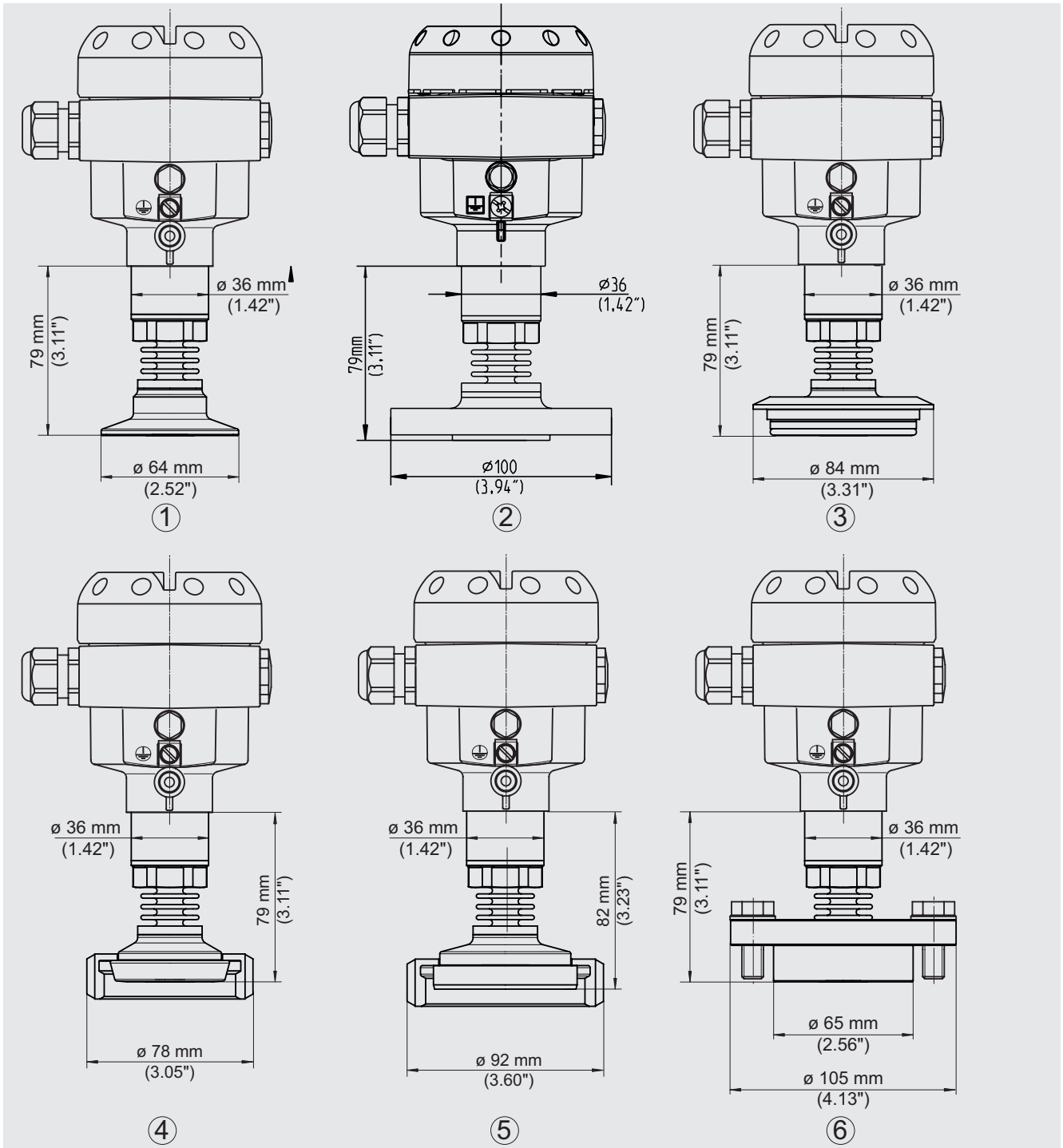

Aseptic process connections for model IPT-21 (version with cooling element)

①	DIN 32676, ISO 2852	Clamp 2", DN 50, PN 16
②	NEUMO BioConnect®	Flange DN 40, form V
③	VARINLINE®	Form N50-40, diameter 68 mm [2.68 in], PN 25
④	DIN 11851	Liner DN 40, PN 40
⑤	DIN 11864	DN 50 liner, RD 78 x 1/8 grooved union nut, PN 40
⑥	DRD retainer flange	PN 40



## Aseptic process connections for model IPT-21

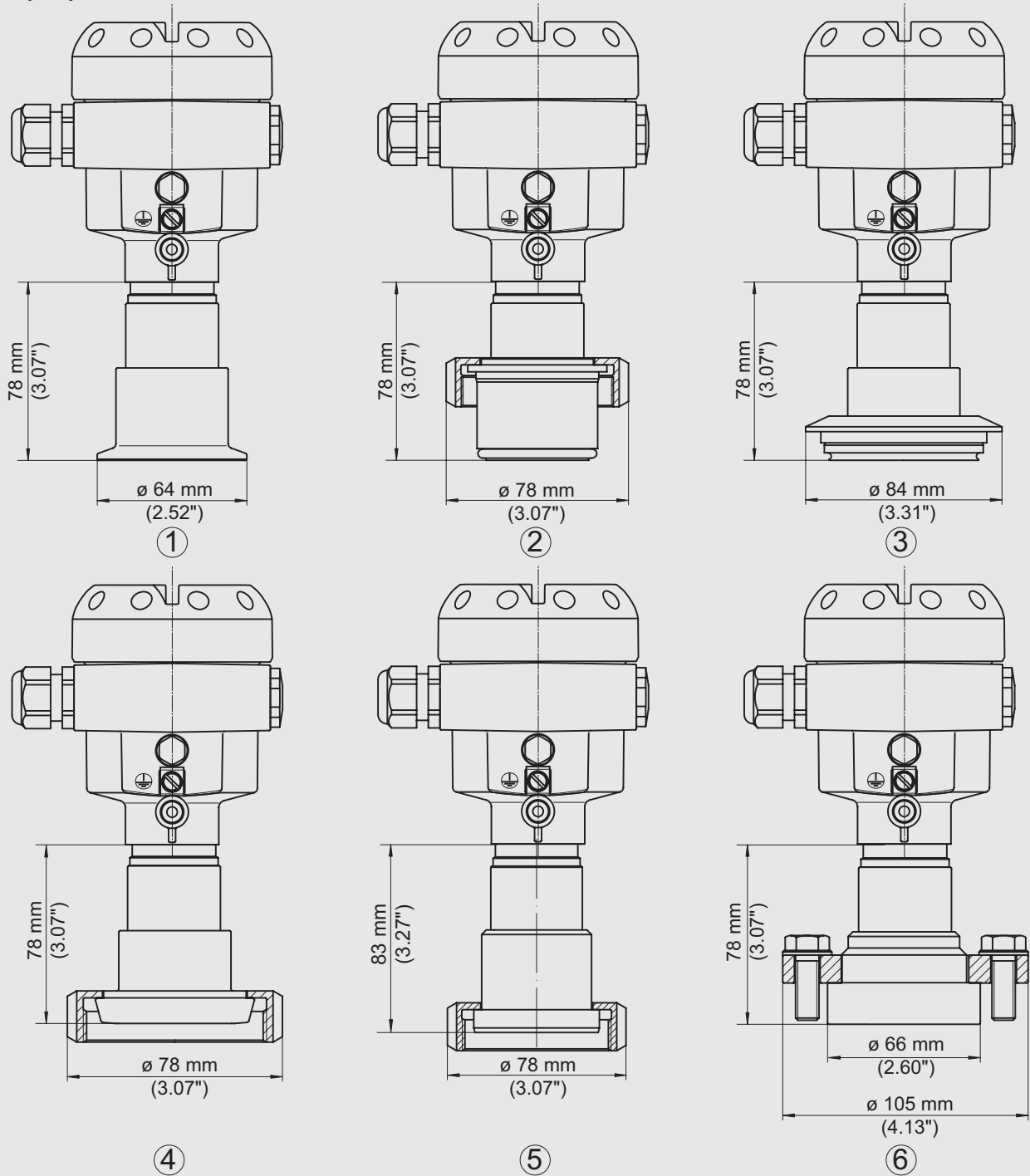

### Aseptic process connections for model IPT-21 (high-temperature version)

①	DIN 32676, ISO 2852	Clamp 2", DN 50, PN 16
②	Aseptic connection with grooved union nut	F40, PN 25
③	VARINLINE®	Form N50-40, diameter 68 mm [2.68 in], PN 25
④	DIN 11851	Liner DN 40, PN 40
⑤	DIN 11864	DN 40 liner, RD 65 x 1/2 grooved union nut, PN 40
⑥	DRD retainer flange	PN 40

## Case dimensions

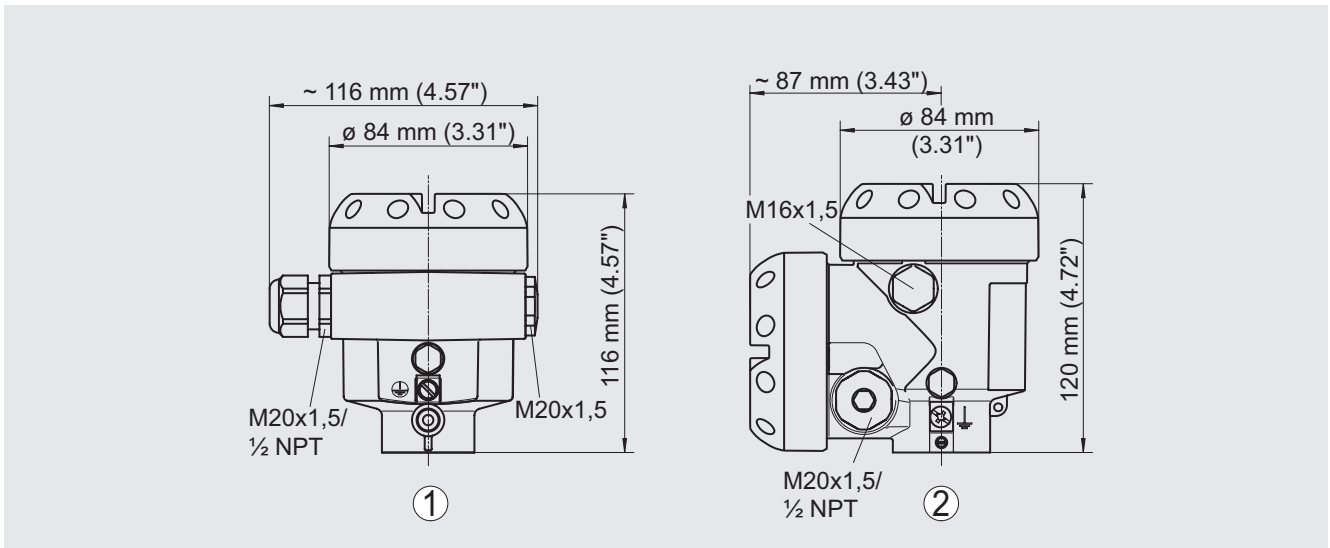

### Case (aluminium)

- ① Single chamber case, powder-coated aluminium
- ② Double chamber case, powder-coated aluminium

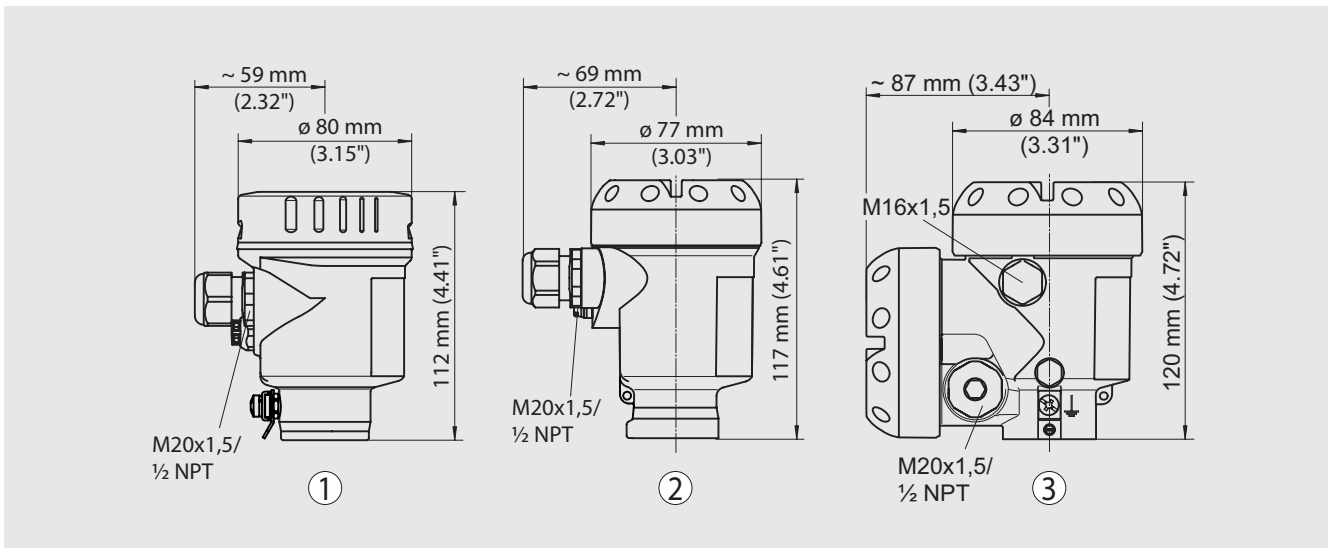

### Case

- ① Single chamber case, deep-drawn and electropolished stainless steel, e.g. for hygienic applications
- ② Single chamber case, plastic ABS or precision-cast stainless steel
- ③ Double chamber case, plastic ABS or precision-cast stainless steel

## User interface DTM

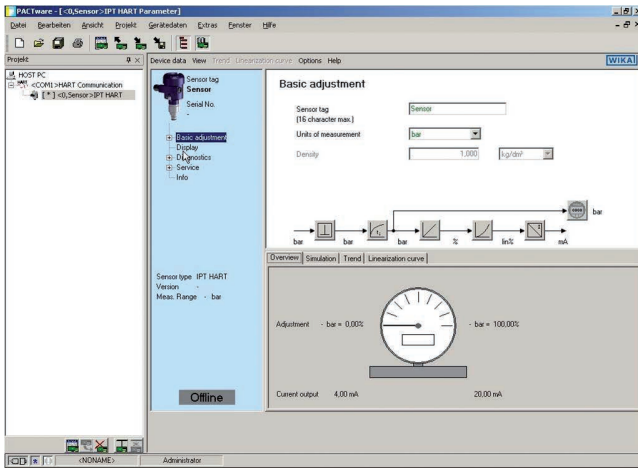

For HART®, PROFIBUS® PA and FF output signals, a DTM is available in accordance with the FDT standard. The DTM provides a self-explanatory and clear user interface for all setup and control processes of the transmitter. For testing purposes, it is also possible to simulate process values and archive the parameter data.

Recording of the measured values is available for diagnostic purposes.

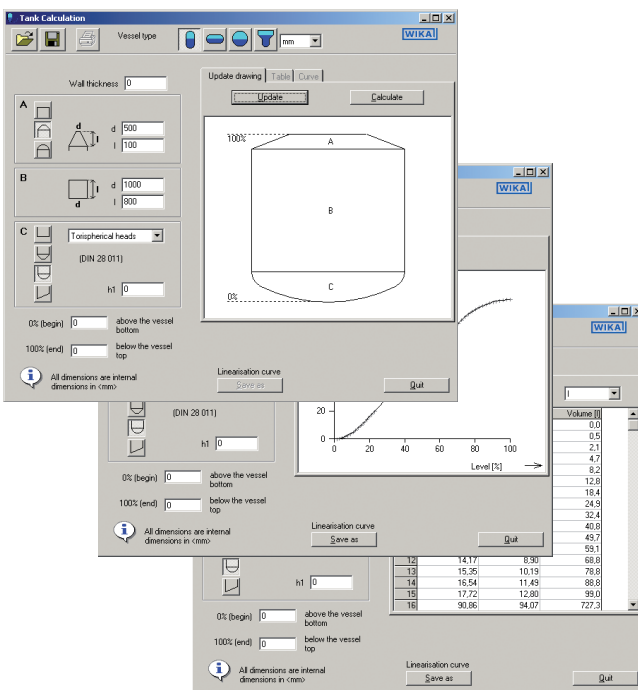

## Tank volume calculation

The additional tank volume calculation of the DTM function can be used to reproduce any optional tank geometry. The corresponding linearisation table is generated automatically. The linearisation table can be transferred directly to the transmitter.

## Accessories

Description	Order number	
 <p><b>Display module, model DIH52-F</b> 5-digit display, 20-segment bar graph, without separate power supply, with additional HART® functionality. Automatic adjustment of measuring range and span. Secondary-master functionality: Setting the measuring range and unit of the connected transmitter using HART® standard commands possible. Optional: Explosion protection per ATEX</p>	On request	
	HART® modem for USB interface, specifically designed for use with notebooks (model 010031)	11025166
	HART® modem for RS-232 interface (model 010001)	7957522
	HART® modem for Bluetooth interface Ex ia IIC (model 010041)	11364254
	PowerXpress HART® modem, with optional power supply (model 010031P)	14133234
	Welding socket for process connection G ½ flush	1192299
	Welding socket for process connection G 1 flush	1192264
	Welding socket for process connection G ½ flush	2158982
	Welding socket for process connection G 1 hygienic flush	2166011
 <p><b>Instrument mounting bracket</b> for wall or pipe mounting, stainless steel</p>	14309985	
	Overvoltage limit for transmitters, 4 ... 20 mA, ½ NPT, series connection, Ex i and Ex d	14013656
	Overvoltage limit for transmitters, 4 ... 20 mA, M20 x 1.5, series connection, Ex i and Ex d	14002489
	Overvoltage limit for transmitters, FF / PROFIBUS, ½ NPT, series connection, Ex i and Ex d	14013658
	Model DI-PT-R display and operating module, case cover aluminium with window	12298884
	Model DI-PT-R display and operating module, case cover electropolished cast stainless steel with safety window	13315269
	Model DI-PT-R display and operating module, case cover plastic with window	13315277
	Model DI-PT-R display and operating module, case cover cast stainless steel with window for single chamber case	12298906
	Model DI-PT-R display and operating module, case cover cast stainless steel with window for double chamber case	14045598
	Model DI-PT-E external display and operating module, aluminium case	12354954
	Model DI-PT-E external display and operating module, cast stainless steel case	12355101
	Model DI-PT-E external display and operating module, plastic case	14134247

### Ordering information

Model / Approval / Case design / Cable and length / Digital display / Output signal / Electrical connection / Measuring range / Process connection / Sealing / Accuracy / Cleaning / Sensor filling / Certificates / Additional requirements

© 04/2018 WIKA Alexander Wiegand SE & Co. KG, all rights reserved.  
The specifications given in this document represent the state of engineering at the time of publishing.  
We reserve the right to make modifications to the specifications and materials.

