

Rosemount™ 2051 Pressure Transmitter



- Rosemount™ Coplanar™ platform enables integration of primary elements, manifolds, and remote seal solutions
- Best-in-class performance with up to 0.05 percent high accuracy option
- IEC 62591 (*WirelessHART*®) enables cost effective installations
- Local Operator Interface (LOI) offers easy to use configuration capabilities at the transmitter
- Protocols available include 4–20 mA HART®, FOUNDATION™ Fieldbus, PROFIBUS® PA, and HART 1–5 Vdc Low Power
- Selectable HART Revision prepares your plant for the latest HART capabilities while ensuring seamless integration with today's systems
- SIL2/3 safety certification to IEC 61508 is available with the full 4–20 mA HART offering to simplify compliance

Contents

Rosemount 2051 Pressure Transmitter product offering..... 2

Rosemount 2051C Coplanar Pressure Transmitter ordering information..... 4

Rosemount 2051T In-line Pressure Transmitter ordering information..... 15

Rosemount 2051G In-line Pressure Transmitter ordering information..... 24

Rosemount™ 2051CF Flow Meters..... 31

Rosemount 2051L Liquid Level Transmitter..... 63

Specifications..... 73

Product certifications..... 89

Dimensional drawings..... 112

Options..... 126

Rosemount 2051 Pressure Transmitter product offering



Foundation of reliable measurement

- Differential, gage, and absolute pressure measurement
- Select from an extensive offering of DP flow meters, liquid level, manifolds, and flanges
- Available with variety of protocols and materials

Best-in-class capabilities extended to IEC 62591 (WirelessHART Protocol)

- Cost effectively implement wireless on the industry's most proven platform
- Optimize safety with the industry's only intrinsically safe power module
- Eliminate wiring design and construction complexities to lower costs by 40–60 percent
- Quickly deploy new pressure, level, and flow measurements in 70 percent less time

Innovative, integrated DP flow meters

- Fully assembled and leak tested for out-of-the-box installation
- Reduce straight pipe requirements, lower permanent pressure loss, and achieve accurate measurement in small line sizes
- Up to two percent volumetric flow accuracy at 5:1 turndown

Proven, reliable, and innovative DP level technologies

- Connect to virtually any process with a comprehensive offering of process connections, fill fluids, direct mount or capillary connections, and materials.
- Quantify and optimize total system performance with QZ option.
- Optimize level measurement with cost efficient Tuned-System™ Assemblies

Instrument manifolds — quality, convenient, and easy

- Designed and engineered for optimal performance with Rosemount transmitters
- Save installation time and money with factory assembly
- Offers a variety of styles, materials, and configurations

Access information when you need it with asset tags

Newly shipped devices include a unique QR code asset tag that enables you to access serialized information directly from the device. With this capability, you can:

- Access device drawings, diagrams, technical documentation, and troubleshooting information in your MyEmerson account
- Improve mean time to repair and maintain efficiency
- Ensure confidence that you have located the correct device
- Eliminate the time-consuming process of locating and transcribing nameplates to view asset information

Rosemount 2051C Coplanar Pressure Transmitter ordering information

Rosemount 2051C Coplanar Pressure Transmitter



- Performance up to 0.05% of span accuracy
- Patented coplanar technology allows direct mounting to pressure, flow or level solutions for installation flexibility
- Delivered fully assembled to manifolds, diaphragm seals or primary flow elements for straightforward installation
- Local Operator Interface offers easy-to-use menus and built-in configuration buttons for streamline commissioning
- SIL 2/3 certified to IEC 61508 (via 3rd party) and prior-use certificate of FMEDA data for safety installations

[CONFIGURE >](#)

[VIEW PRODUCT >](#)

Online product configurator

Many products are configurable online using our Product Configurator. Select the **Configure** button or visit our [website](#) to start. With this tool's built-in logic and continuous validation, you can configure your products more quickly and accurately.

Specifications and options

See the Specifications and options section for more details on each configuration. Specification and selection of product materials, options, or components must be made by the purchaser of the equipment. See the Material selection section for more information.

Model codes

Model codes contain the details related to each product. Exact model codes will vary; an example of a typical model code is shown in [Figure 1](#).

Figure 1: Model Code Example

3051C D 2 X 2 2 M5 B4

1 2

1. Required model components (choices available on most)
2. Additional options (variety of features and functions that may be added to products)

Optimizing lead time

The starred offerings (★) represent the most common options and should be selected for best delivery. The non-starred offerings are subject to additional delivery lead time.

Required model components

Model

Code	Description	
2051C	Coplanar Pressure Transmitter	★

Measurement type

Code	Description	
D	Differential	★
G	Gage	★

Pressure range

Code	Differential (Rosemount 2051CD)	Gage (Rosemount 2051CG)	
1	-25 to 25 inH ₂ O (-62.2 to 62.2 mbar)	-25 to 25 inH ₂ O (-62.2 to 62.2 mbar)	★
2	-250 to 250 inH ₂ O (-623 to 623 mbar)	-250 to 250 inH ₂ O (-623 to 623 mbar)	★
3	-1000 to 1000 inH ₂ O (-2.5 to 2.5 bar)	-393 to 1000 inH ₂ O (-0.98 to 2.5 bar)	★
4	-300 to 300 psi (-20.7 to 20.7 bar)	-14.2 to 300 psi (-0.98 to 20.7 bar)	★
5	-2000 to 2000 psi (-137.9 to 137.9 bar)	-14.2 to 2000 psi (-0.98 to 137.9 bar)	★

Transmitter output

Code	Description	
A ⁽¹⁾	4–20 mA with digital signal based on HART® Protocol	★
F	FOUNDATION™ Fieldbus Protocol	★
W ⁽²⁾	PROFIBUS® PA Protocol	★
X ⁽³⁾	Wireless	★
M ⁽⁴⁾	Low-power, 1–5 Vdc with digital signal based on HART Protocol	

(1) HART Revision 5 is the default HART output. The Rosemount 2051 with Selectable HART can be factory or field configured to HART Revision 7. To order HART Revision 7 factory configured, add option code HR7.

(2) For local addressing and configuration, M4 (LOI) is required. Not available with product certification codes E4, EM, EP, I6, IM, KD, KL, KM, KP, KS, N3

(3) Only available with intrinsically safe approvals.

(4) Only available with Housing Codes A and J and with C6, E2,E5, I5, K5, EM, EP, KB, and E8 product certifications.

Transmitter flange type, material, drain/vent

Code	Description	Flange material	Drain/vent	
2	Coplanar	SST	SST	★
3 ⁽¹⁾		Cast C-276	Alloy C-276	
5		Plated CS	SST	★
7 ⁽¹⁾		SST	Alloy C-276	★
8 ⁽¹⁾		Plated CS	Alloy C-276	★
0	Alternate process connection			★

(1) Materials of construction comply with recommendations per NACE® MR0175/ISO 15156 for sour oil field production environments. Environmental limits apply to certain materials. Consult latest standard for details. Selected materials also conform to NACE MR0103 for sour refining environments. Order with Q15 or Q25 to receive a NACE certificate.

Isolating diaphragm

Code	Description	
2	316L SST	★
3	Alloy C-276	★
5 ⁽¹⁾⁽²⁾	Tantalum	

(1) Available in ranges 2–5 only.

(2) Not available with output code X.

O-ring

Code	Description	
A	Glass-filled PTFE	★
B	Graphite-filled PTFE	★

Sensor fill fluid

Code	Description	
1	Silicone	★
2 ⁽¹⁾	Inert (differential and gage only)	★

(1) Not available with wireless output (code X).

Housing material

Code	Description	Conduit entry size	
A	Aluminum	½–14 NPT	★
B	Aluminum	M20 x 1.5	★
E	Aluminum, ultra low copper	½–14 NPT	★
F	Aluminum, ultra low copper	M20 x 1.5	★
J	SST	½–14 NPT	★
K	SST	M20 x 1.5	★
P ⁽¹⁾	Engineered polymer	No conduit entries	★

D ⁽²⁾	Aluminum	G½	★
M ⁽²⁾	SST	G½	

(1) Only available with output code X.

(2) Transmitter conduit entry will be ½ NPT and a ½ NPT to G½ thread adapter will be provided. This option is only available with product certifications options I1, I2, I3, I7, IA, IB, IM, KA, N1, N3, N7. Housing code D is also available with E4, and IG.

Wireless options

Requires wireless output code X and engineered polymer housing code P.

Wireless transmit rate, operating frequency, and protocol

Code	Description	
WA3	User configurable transmit rate, 2.4 GHz WirelessHART ®	★

Antenna and SmartPower™

Code	Description	
WP5	Internal antenna, compatible with Green Power Module (I.S. Power Module sold separately)	★

Additional options

Extended product warranty

Code	Description	
WR3	3-year limited warranty	★
WR5	5-year limited warranty	★

Plantweb™ control functionality

Code	Description	
A01	FOUNDATION™ Fieldbus advance control function block suite	★

Alternate flange

The alternate flange option code requires the 0 code in materials of construction for alternate process connection.

Code	Description	
H2	Traditional flange, 316 SST, SST drain/vent	★
H3 ⁽¹⁾	Traditional flange, alloy C, alloy C-276 drain/vent	★
H7 ⁽¹⁾	Traditional flange, 316 SST, alloy C-276 drain/vent	★
HJ	DIN-compliant traditional flange, SST, 7/16-in. (10 mm) adapter/manifold bolting	★
FA	Level flange, SST, 2-in. (51 mm), ANSI Class 150, vertical mount	★
FB	Level flange, SST, 2-in. (51 mm), ANSI Class 300, vertical mount	★
FC	Level flange, SST, 3-in. (76 mm), ANSI Class 150, vertical mount	★
FD	Level flange, SST, 3-in. (76 mm), ANSI Class 300, vertical mount	★

FP	DIN level flange, SST, DN 50, PN 40, vertical mount	★
FQ	DIN level flange, SST, DN 80, PN 40, vertical mount	★
HK ⁽²⁾	DIN compliant traditional flange, SST, 10 mm adapter/manifold bolting	
HL	DIN compliant traditional flange, SST, 12 mm adapter/manifold bolting	

- (1) *Materials of construction comply with recommendations per NACE MR0175/ISO 15156 for sour oil field production environments. Environmental limits apply to certain materials. Consult latest standard for details. Selected materials also conform to NACE MR0103 for sour refining environments. Order with Q15 or Q25 to receive a NACE certificate.*
- (2) *Not valid with optional code P9 for 4500 psi static pressure.*

Manifold assembly

“Assemble-to” items are specified separately and require a completed model number.

Code	Description	
S5	Assemble to Rosemount 305 Integral Manifold	★
S6	Assemble to Rosemount 304 Manifold or Connection System	★

Integral mount primary element

Not valid with option code P9 for 4500 static pressure. “Assemble-to” items are specified separately and require a completed model number.

Code	Description	
S3	Assemble to Rosemount 405 Compact Orifice Plate	★
S4 ⁽¹⁾	Assemble to Rosemount Annubar™ or Rosemount 1195 Integral Orifice	★

- (1) *Transmitter flange limited to coplanar (option codes 2, 3, 5, 7, or 8) or traditional (option codes H2, H3, or H7).*

Seal assemblies

“Assemble-to” items are specified separately and require a completed model number.

Code	Description	
S1 ⁽¹⁾	Assemble to one Rosemount 1199 seal	★
S2 ⁽²⁾	Assemble to two Rosemount 1199 seals	★

- (1) *Not valid with option code D9 for RC1/2 adapters.*
- (2) *Not valid for option codes DF and D9 for adapters.*

Mounting brackets

Code	Description	
B1	Traditional flange bracket for 2-in. pipe mounting, CS bolts	★
B2	Traditional flange bracket for panel mounting, CS bolts	★
B3	Traditional flange flat bracket for 2-in. pipe mounting, CS bolts	★
B4	Coplanar flange bracket for 2-in. pipe or panel mounting, all SST	★
B7	B1 bracket with Series 300 SST bolts	★
B8	B2 bracket with Series 300 SST bolts	★
B9	B3 bracket with Series 300 SST bolts	★
BA	SST B1 bracket with Series 300 SST bolts	★

Code	Description	
BC	SST B3 bracket with Series 300 SST bolts	★

Product certifications

Code	Description	
E8	ATEX Flameproof and Dust Certification	★
I1 ⁽¹⁾	ATEX Intrinsic Safety and Dust	★
IA	ATEX FISCO Intrinsic Safety; for FOUNDATION™ Fieldbus or PROFIBUS® PA Protocol only	★
N1	ATEX Type n Certification and Dust	★
K8	ATEX Flameproof, Intrinsic Safety, Type n, Dust (combination of E8, I1 and N1)	★
E4	TIIS Flame-proof	★
I4	TIIS Intrinsic Safety	★
E5	USA Explosion-proof, Dust Ignition-Proof	★
I5 ⁽²⁾	USA Intrinsically Safe, Nonincendive	★
C6	Canada Explosion-proof, Dust Ignition-proof, Intrinsically Safe, and Division 2	★
E6	Canada Explosion-proof, Dust Ignition-proof, Division 2	★
I6	Canada Intrinsic Safety	★
K6	Canada and ATEX Explosion-proof, Intrinsically Safe, and Division 2 (combination of C6, E8, and I1)	★
E7	IECEX Flameproof, Dust Ignition-proof	★
I7	IECEX Intrinsic Safety	★
N7	IECEX Type n Certification	★
K7	IECEX Flame-proof, Dust Ignition-proof, Intrinsic Safety, and Type n (combination of I7, N7, and E7)	★
IG	IECEX FISCO Intrinsically Safe; for FOUNDATION Fieldbus or PROFIBUS PA Protocols only	★
K5	USA Explosion-proof, Dust Ignition-Proof, Intrinsically Safe, and Division 2	★
E2	INMETRO Flameproof001	★
I2	INMETRO Intrinsic Safety	★
IB	INMETRO FISCO intrinsically safe; for FOUNDATION Fieldbus or PROFIBUS PA Protocols only	★
K2	INMETRO Flameproof, Intrinsic Safety	★
E3	China Flameproof	★
I3	China Intrinsic Safety	★
N3	China Type n	★
EM	Technical Regulations Customs Union (EAC) Flameproof	★
IM	Technical Regulations Customs Union (EAC) Intrinsic Safety	★
KM	Technical Regulations Customs Union (EAC) Flameproof and Intrinsic Safety	★
KB	USA and Canada Explosion-proof, Dust Ignition Proof, Intrinsically Safe, and Division 2 (combination of K5 and C6)	★
KD	USA, Canada, and ATEX Explosion-proof, Intrinsically Safe (combination of K5, C6, I1, and E8)	★

KL ⁽³⁾	USA, Canada, IECEx, ATEX Intrinsic Safety Combination	★
KS	USA, Canada, IECEx, ATEX Explosion Proof, Intrinsically Safe, Dust, Non-Incendive, Type-N, Div. 2	★
EP	Republic of Korea Flameproof	★
IP	Republic of Korea Intrinsic Safety	★
KP	Republic of Korea Flameproof, Intrinsic Safety	★

- (1) Dust approval not applicable to output code X.
- (2) Nonincendive certification not provided with output code (X).
- (3) Only available with output code X.

Drinking water approval

This approval is not available with Alloy C-276 isolator (code 3), tantalum isolator (code 5), all cast C-276 flanges, all plated carbon steel (CS) flanges, all DIN flanges, all level flanges, assemble-to manifolds (codes S5 and S6), assemble-to seals (codes S1 and S2), assemble-to primary elements (codes S3 and S4), surface finish certification (code Q16), and remote seal system report (code QZ).

Code	Description	
DW	NSF drinking water approval	★

Shipboard approvals

Shipboard approvals are not available with wireless output (code X).

Code	Description	
SBS	American Bureau of Shipping	★
SBV	Bureau Veritas (BV)	★
SDN	Det Norske Veritas	★
SLL	Lloyds Register (LR)	★

SST tagging

Code	Description	
Y2	316SST Nameplate, top tag, wire-on tag, and fasteners	

Bolting material

Code	Description	
L4	Austenitic 316 SST bolts	★
L5	ASTM A 193, grade B7M bolts	★
L6	Alloy K-500 bolts	★
L8	ASTM A 193 Class 2, Grade B8M bolts	★

Display and interface options

Code	Description	
M4 ⁽¹⁾	LCD display with LOI	★

M5	LCD display	★
----	-------------	---

(1) Not available with FOUNDATION™ Fieldbus (output code F) or wireless (output code X).

Hardware adjustments

Code	Description	
D4 ⁽¹⁾	Zero and span configuration buttons	★
DZ ⁽²⁾	Digital zero trim	★

(1) Only available with 4-20 mA HART® (output code A) and Low Power (output code M)

(2) Only available with 4-20 mA HART (output code A), Low Power (output code M), and wireless (output code X)

Flange adapters

This option is not valid with alternate process connection options S3, S4, S5, or S6.

Code	Description	
DF	½–14 NPT flange adapters	★

Conduit plug

Not available with output code X. Transmitter is shipped with 316 SST conduit plug (uninstalled) in place of standard CS conduit plug.

Code	Description	
DO	316 SST conduit plug	★

RC¼ RC½ process connection

This option is not available with alternate process connection, DIN flanges, and level flanges.

Code	Description	
D9	RC¼ flange with RC½ flange adapter - SST	

Ground screw

The ground screw option is not available with wireless output (code X). The V5 option is not needed with the T1 option; external ground screw assembly is included with the T1 option.

Code	Description	
V5	External ground screw assembly	★

Performance

Available with 4–20 mA HART (output code A), wireless (output code X), FOUNDATION Fieldbus (output code F), Rosemount 2051C Ranges 2–5 or Rosemount 2051T Ranges 1–4, SST and, alloy C-276 diaphragms and silicone fill fluid. High performance option includes 0.05 percent reference accuracy, and five year stability. See Performance specifications for details.

Code	Description	
P8	High performance option	★

Transient protection

The transient protection option is not available with wireless output (code X). The T1 option is not needed with FISCO Product Certifications; transient protection is included in the FISCO product certification codes IA, IB, and IE.

Code	Description	
T1	Transient protection terminal block	★

Software configuration

The software configuration option is only available with HART 4–20 mA output (output code A) and wireless output (output code X).

Code	Description	
C1	Custom software configuration (completed Rosemount 2051 Configuration Data Sheet or Rosemount 2051 Wireless Configuration Data Sheet .)	★

Alarm limit

The option is not available with FOUNDATION™ Fieldbus (output code F) or wireless (output code X).

Code	Description	
C4	NAMUR alarm and saturation levels, high alarm	★
CN	NAMUR alarm and saturation levels, low alarm	★
CR	Custom alarm and saturation signal levels, high alarm (requires C1 and Configuration Data Sheet)	★
CS	Custom alarm and saturation signal levels, low alarm (requires C1 and Configuration Data Sheet)	★
CT	Low alarm (standard Rosemount alarm and saturation levels)	★

Pressure testing

Code	Description	
P1 ⁽¹⁾	Hydrostatic testing with certificate	★

(1) Not available with pressure range 0.

Cleaning process area

This option is not valid with alternate process connection S5.

Code	Description	
P2	Cleaning for special service	
P3	Cleaning for < 1 ppm chlorine/fluorine	

Maximum static line pressure

Code	Description	
P9	4500 psig (310 bar) static pressure limit (Rosemount 2051CD Ranges 2–5 only)	★

Calibration certificate

Code	Description	
Q4	Calibration Certificate	★
QG ⁽¹⁾	Calibration Certificate and GOST Verification Certificate	★
QP	Calibration certification and tamper evident seal	★

(1) Contact an Emerson representative for availability.

Material traceability certification

Code	Description	
Q8	Material traceability certification per EN 10204 3.1	★

Positive material identification (PMI)

Code	Description	
Q76	PMI verification and certificate	★

Quality certification for safety

The quality certification for safety is only available with HART® 4–20 mA output (code A).

Code	Description	
QT	Safety certified to IEC 61508 with certificate of FMEDA	★

Surface finish

Code	Description	
Q16	Surface finish certification for sanitary remote seals	★

Toolkit total system performance reports

Code	Description	
QZ	Remote seal system performance calculation report	★

Conduit electrical connector

The conduit electrical connector option is not available with wireless output (code X).

Code	Description	
GE	M12, 4-pin, male connector (eurofast®)	★
GM	A size mini, 4-pin, male connector (minifast®)	★

NACE® Certificate

Note that NACE-compliant wetted materials are required. Materials of construction must comply with recommendations per NACE MR0175/ISO 15156 for sour oil field production environments. Environmental limits apply to certain materials. Consult the latest standard for details. All selected materials must also conform to NACE MR0103 for sour refining environments.

Code	Description	
Q15	Certificate of Compliance to NACE MR0175/ISO 15156 for wetted materials	★
Q25	Certificate of Compliance to NACE MR0103 for wetted materials	★

HART revision configuration

Only available with 4–20 mA HART® (output code A).

Code	Description	
HR5 ⁽¹⁾	Configured for HART Revision 5	★
HR7 ⁽²⁾	Configured for HART Revision 7	★

(1) Configures the HART output to HART Revision 5. The device can be field configured to HART Revision 7 if needed.

(2) Configures the HART output to HART Revision 7. The device can be field configured to HART Revision 5 if needed.

Wireless power accessory

This option is only available with output code X.

Code	Description	
HS	Hot swap power adapter for power module replacement	

Rosemount 2051T In-line Pressure Transmitter ordering information

Rosemount 2051T In-line Pressure Transmitter ordering information



- Intuitive Local Operator Interface streamlines commissioning for simple and cost-effective installation
- SIL 2/3 certified to IEC 61508 (via 3rd party) and prior-use certificate of FMEDA data for safety installations

[CONFIGURE >](#) [VIEW PRODUCT >](#)

Online product configurator

Many products are configurable online using our Product Configurator. Select the **Configure** button or visit our [website](#) to start. With this tool's built-in logic and continuous validation, you can configure your products more quickly and accurately.

Specifications and options

See the Specifications and options section for more details on each configuration. Specification and selection of product materials, options, or components must be made by the purchaser of the equipment. See the Material selection section for more information.

Model codes

Model codes contain the details related to each product. Exact model codes will vary; an example of a typical model code is shown in [Figure 2](#).

Figure 2: Model Code Example

3051C D 2 X 2 2 M5 B4

1 2

1. Required model components (choices available on most)
2. Additional options (variety of features and functions that may be added to products)

Optimizing lead time

The starred offerings (★) represent the most common options and should be selected for best delivery. The non-starred offerings are subject to additional delivery lead time.

Required model components

Model

Code	Description	
2051T	In-Line Pressure Transmitter	★

Pressure type

Code	Description	
G	Gage	★
A ⁽¹⁾	Absolute	★

(1) *Wireless (output code X) only available in absolute measurement type in range 1–5 with ½–14 NPT process connection (code 2B), and housing (code P).*

Pressure range

Code	Gage (Rosemount 2051TG)	Absolute (Rosemount 2051TA)	
0	–5 to 5 psi (–344.74 to 344.74 mbar)	N/A	★
1	–14.7 to 30 psi (–1.0 to 2.1 bar)	0 to 30 psia (0 to 2.1 bar)	★
2	–14.7 to 150 psi (–1.0 to 10.3 bar)	0 to 150 psi (0 to 10.3 bar)	★
3	–14.7 to 800 psi (–1.0 to 55 bar)	0 to 800 psi (0 to 55 bar)	★
4	–14.7 to 4000 psi (0 to 276 bar)	0 to 4000 psi (0 to 276 bar)	★
5	–14.7 to 10000 psi (–1.0 to 689 bar)	0 to 10000 psi (0 to 689 bar)	★

Transmitter output

Code	Description	
A ⁽¹⁾	4–20 mA with digital signal based on HART® Protocol	★
F	FOUNDATION™ Fieldbus Protocol	★
W ⁽²⁾	PROFIBUS® PA Protocol	★
X ⁽³⁾	Wireless	★
M ⁽⁴⁾	Low-power, 1–5 Vdc with digital signal based on HART Protocol	

(1) *HART Revision 5 is the default HART output. The Rosemount 2051 with Selectable HART can be factory or field configured to HART Revision 7. To order HART Revision 7 factory configured, add option code HR7.*

(2) *For local addressing and configuration, M4 (LOI) is required. Not available with product certification codes E4, EM, EP, I6, IM, KD, KL, KM, KP, KS, N3*

(3) *Only available with intrinsically safe approvals.*

(4) *Only available with Housing Codes A and J and with C6, E2, E5, I5, K5, EM, EP, KB, and E8 product certifications.*

Process connection style

Code	Description	
2B	½–14 NPT female	★
2C ⁽¹⁾	G½ A DIN 16288 male	★
2F ⁽²⁾	Coned and threaded, compatible with autoclave type F-250-C (range 5 only)	

(1) Wireless (output code X) only available in G½ A DIN 16288 Male process connection (code 2C) with range 1–4, 316 SST isolating diaphragm (code 2), silicone fill fluid (code 1), and housing (code P).

(2) Not available with output code X.

Isolating diaphragm

Code	Isolating diaphragm	Process connection wetted parts material	
2	316L SST	316L SST	★
3	Alloy C-276	Alloy C-276	★

Sensor fill fluid

Code	Description	
1	Silicone	★
2 ⁽¹⁾	Inert	★

(1) Not available with output code X.

Housing material

Code	Description	Conduit entry size	
A	Aluminum	½–14 NPT	★
B	Aluminum	M20 x 1.5	★
E	Aluminum, ultra low copper	½–14 NPT	★
F	Aluminum, ultra low copper	M20 x 1.5	★
J	SST	½–14 NPT	★
K	SST	M20 x 1.5	★
P ⁽¹⁾	Engineered polymer	No conduit entries	★
D ⁽²⁾	Aluminum	G½	★
M ⁽²⁾	SST	G½	

(1) Only available with output code X.

(2) Transmitter conduit entry will be ½ NPT and a ½ NPT to G½ thread adapter will be provided. This option is only available with product certifications options I1, I2, I3, I7, IA, IB, IM, KA, N1, N3, N7. Housing code D is also available with E4, and IG.

Wireless options

Requires wireless output code X and engineered polymer housing code P.

Wireless transmit rate, operating frequency, and protocol

Code	Description	
WA3	User configurable transmit rate, 2.4 GHz <i>WirelessHART</i> ®	★

Antenna and SmartPower™

Code	Description	
WP5	Internal antenna, compatible with Green Power Module (I.S. Power Module sold separately)	★

Additional options

Extended product warranty

Code	Description	
WR3	3-year limited warranty	★
WR5	5-year limited warranty	★

Plantweb™ control functionality

Code	Description	
A01	FOUNDATION Fieldbus advanced control function block suite	★

Manifold assemblies

“Assemble-to” items are specified separately and require a completed model number.

Code	Description	
S5	Assemble to Rosemount 306 Integral Manifold	★

Seal assemblies

“Assemble-to” items are specified separately and require a completed model number.

Code	Description	
S1	Assemble to one Rosemount 1199 diaphragm seal	★

Mounting bracket

Code	Description	
B4	Bracket for 2-in. pipe or panel mounting, all SST	★

Product certifications

Code	Description	
E8	ATEX Flameproof and Dust Certification	★
I1 ⁽¹⁾	ATEX Intrinsic Safety and Dust	★
IA	ATEX FISCO Intrinsic Safety; for FOUNDATION™ Fieldbus or PROFIBUS® PA Protocol only	★
N1	ATEX Type n Certification and Dust	★
K8	ATEX Flameproof, Intrinsic Safety, Type n, Dust (combination of E8, I1 and N1)	★
E4	TIIS Flame-proof	★
I4	TIIS Intrinsic Safety	★
E5	USA Explosion-proof, Dust Ignition-Proof	★
I5 ⁽²⁾	USA Intrinsically Safe, Nonincendive	★
C6	Canada Explosion-proof, Dust Ignition-proof, Intrinsically Safe, and Division 2	★
E6	Canada Explosion-proof, Dust Ignition-proof, Division 2	★
I6	Canada Intrinsic Safety	★
K6	Canada and ATEX Explosion-proof, Intrinsically Safe, and Division 2 (combination of C6, E8, and I1)	★
E7	IECEX Flameproof, Dust Ignition-proof	★
I7	IECEX Intrinsic Safety	★
N7	IECEX Type n Certification	★
K7	IECEX Flame-proof, Dust Ignition-proof, Intrinsic Safety, and Type n (combination of I7, N7, and E7)	★
IG	IECEX FISCO Intrinsically Safe; for FOUNDATION Fieldbus or PROFIBUS PA Protocols only	★
K5	USA Explosion-proof, Dust Ignition-Proof, Intrinsically Safe, and Division 2	★
E2	INMETRO Flameproof001	★
I2	INMETRO Intrinsic Safety	★
IB	INMETRO FISCO intrinsically safe; for FOUNDATION Fieldbus or PROFIBUS PA Protocols only	★
K2	INMETRO Flameproof, Intrinsic Safety	★
E3	China Flameproof	★
I3	China Intrinsic Safety	★
N3	China Type n	★
EM	Technical Regulations Customs Union (EAC) Flameproof	★
IM	Technical Regulations Customs Union (EAC) Intrinsic Safety	★
KM	Technical Regulations Customs Union (EAC) Flameproof and Intrinsic Safety	★
KB	USA and Canada Explosion-proof, Dust Ignition Proof, Intrinsically Safe, and Division 2 (combination of K5 and C6)	★
KD	USA, Canada, and ATEX Explosion-proof, Intrinsically Safe (combination of K5, C6, I1, and E8)	★
KL ⁽³⁾	USA, Canada, IECEX, ATEX Intrinsic Safety Combination	★
KS	USA, Canada, IECEX, ATEX Explosion Proof, Intrinsically Safe, Dust, Non-Incendive, Type-N, Div. 2	★
EP	Republic of Korea Flameproof	★
IP	Republic of Korea Intrinsic Safety	★

KP	Republic of Korea Flameproof, Intrinsic Safety	★
----	--	---

- (1) Dust approval not applicable to output code X.
- (2) Nonincendive certification not provided with output code (X).
- (3) Only available with output code X.

Drinking water approval

This option is not available with coned and threaded connection (2F code), assemble-to manifold (S5 code), assemble-to seal (S1 code), surface finish certification (Q16 code), remote seal system report (QZ code).

Code	Description	
DW	NSF drinking water approval	★

Shipboard approvals

Shipboard approvals are not available with wireless output (code X).

Code	Description	
SBS	American Bureau of Shipping	★
SBV	Bureau Veritas (BV)	★
SDN	Det Norske Veritas	★
SLL	Lloyds Register (LR)	★

SST tagging

Code	Description	
Y2	316SST Nameplate, top tag, wire-on tag, and fasteners	

Display and interface options

Code	Description	
M4 ⁽¹⁾	LCD display with LOI	★
M5	LCD display	★

- (1) Not available with FOUNDATION™ Fieldbus (output code F) or wireless (output code X).

Hardware adjustments

Code	Description	
D4 ⁽¹⁾	Zero and span configuration buttons	★
DZ ⁽²⁾	Digital zero trim	★

- (1) Only available with 4-20 mA HART® (output code A) and Low Power (output code M)
- (2) Only available with 4-20 mA HART (output code A), Low Power (output code M), and wireless (output code X)

Wireless SST sensor module

This option is only available with output code X.

Code	Description	
WSM	Wireless SST sensor module	★

Conduit plug

Not available with output code X. Transmitter is shipped with 316 SST conduit plug (uninstalled) in place of standard CS conduit plug.

Code	Description	
DO	316 SST conduit plug	★

Ground screw

This option is not available with output code x. The V5 option is not needed with the T1 option; external ground screw assembly is included with the T1 option.

Code	Description	
V5	External ground screw assembly	★

Performance

Available with 4–20 mA HART (output code A), wireless (output code X), FOUNDATION Fieldbus (output code F), Rosemount 2051C Ranges 2–5 or Rosemount 2051T Ranges 1–4, SST and, alloy C-276 diaphragms and silicone fill fluid. High performance option includes 0.05 percent reference accuracy, and five year stability. See Performance specifications for details.

Code	Description	
P8	High performance option	★

Terminal blocks

This option is not available with output code x. The T1 option is not needed with FISCO Product Certifications; transient protection is included in the FISCO product certification codes IA and IE.

Code	Description	
T1	Transient protection terminal block	★

Software configuration

The software configuration option is only available with HART 4–20 mA output (output code A) and wireless output (output code X).

Code	Description	
C1	Custom software configuration (completed Rosemount 2051 Configuration Data Sheet or Rosemount 2051 Wireless Configuration Data Sheet .)	★

Alarm limit

The option is not available with FOUNDATION Fieldbus (output code F) or wireless (output code X).

Code	Description	
C4	NAMUR alarm and saturation levels, high alarm	★
CN ⁽¹⁾	NAMUR alarm and saturation levels, low alarm	★
CR	Custom alarm and saturation signal levels, high alarm (requires C1 and Configuration Data Sheet)	★
CS	Custom alarm and saturation signal levels, low alarm (requires C1 and Configuration Data Sheet)	★

Code	Description	
CT	Low alarm (standard Rosemount alarm and saturation levels)	★

(1) Only available with 4–20 mA HART (output code A).

Pressure testing

Code	Description	
P1 ⁽¹⁾	Hydrostatic testing with certificate	★

(1) Not available with pressure range 0.

Cleaning process area

This option is not valid with alternate process connection S5.

Code	Description	
P2	Cleaning for special service	
P3	Cleaning for < 1 ppm chlorine/fluorine	

Calibration certification

Code	Description	
Q4	Calibration certificate	★

Material traceability certification

Code	Description	
Q8	Material traceability certification per EN 10204 3.1	★

Positive material identification (PMI)

Code	Description	
Q76	PMI verification and certificate	★

Quality certification for safety

This option is only available with 4–20 mA HART (output code A).

Code	Description	
QT	Safety certified to IEC 61508 with certificate of FMEDA	★

Surface finish

Code	Description	
Q16	Surface finish certification for sanitary remote seals	★

Toolkit total system performance reports

Code	Description	
QZ	Remote seal system performance calculation report	★

Conduit electrical connector

This option is not available with output code X.

Code	Description	
GE	M12, 4-pin, male connector (eurofast®)	★
GM	A size mini, 4-pin, male connector (minifast®)	★

NACE® certificate

NACE Compliant wetted materials are identified by materials of construction that comply with recommendations per NACE MR0175/ISO 15156 for sour oil field production environments. Environmental limits apply to certain materials. Consult latest standard for details. Selected materials also conform to NACE MR0103 for sour refining).

Code	Description	
Q15	Certificate of compliance to NACE MR0175/ISO 15156 for wetted materials	★
Q25	Certificate of compliance to NACE MR0103 for wetted materials	★

HART revision configuration

Available with 4–20 mA HART (output code A), wireless (output code X), FOUNDATION™ Fieldbus (output code F), Rosemount 2051C Ranges 2–5 or Rosemount 2051T Ranges 1–4, SST and Alloy C 276 diaphragms and silicone fill fluid. High performance option includes 0.05 percent reference accuracy, and five year stability.

Code	Description	
HR5 ⁽¹⁾	Configured for HART Revision 5	★
HR7 ⁽²⁾	Configured for HART Revision 7	★

(1) Configures the HART output to HART Revision 5. The device can be field configured to HART Revision 7 if needed.

(2) Configures the HART output to HART Revision 7. The device can be field configured to HART Revision 5 if needed.

Wireless power accessory

This option is only available with output code X.

Code	Description	
HS	Hot swap power adapter for power module replacement	

Rosemount 2051G In-line Pressure Transmitter ordering information



- Patented coplanar technology allows direct mounting to pressure, flow or level solutions for installation flexibility
- Delivered fully assembled to manifolds, diaphragm seals or primary flow elements for straightforward installation
- Local Operator Interface offers easy-to-use menus and built-in configuration buttons for streamline commissioning

Online product configurator

Many products are configurable online using our Product Configurator. Select the **Configure** button or visit our [website](#) to start. With this tool's built-in logic and continuous validation, you can configure your products more quickly and accurately.

Specifications and options

See the Specifications and options section for more details on each configuration. Specification and selection of product materials, options, or components must be made by the purchaser of the equipment. See the Material selection section for more information.

Model codes

Model codes contain the details related to each product. Exact model codes will vary; an example of a typical model code is shown in [Figure 3](#).

Figure 3: Model Code Example

3051C D 2 X 2 2 M5 B4

1 2

1. Required model components (choices available on most)
2. Additional options (variety of features and functions that may be added to products)

Optimizing lead time

The starred offerings (★) represent the most common options and should be selected for best delivery. The non-starred offerings are subject to additional delivery lead time.

Required model components

Model

Code	Description	
2051G	In-line pressure transmitter	★

Pressure type

Code	Description		
P	Gage	★	
A	Absolute	★	
	Rosemount 2051GP	Rosemount 2051GA	
1	-14.7 to 30 psi (-1.0 to 2.1 bar)	0 to 30 psi (0 to 2.1 bar)	★
2	-14.7 to 150 psi (-1.0 to 10.3 bar)	0 to 150 psi (0 to 10.3 bar)	★
3	-14.7 to 800 psi (-1.0 to 55 bar)	0 to 800 psi (0 to 55 bar)	★
4	-14.7 to 4000 psi (-1.0 to 276 bar)	0 to 4000 psi (0 to 276 bar)	★

Transmitter output

Code	Description	
A	4–20 mA with digital signal based on HART® Protocol	★

Process connection style

Code	Description	
2B	½–14 NPT female	★
2C	G½ A DIN 16288 male	★

Isolating diaphragm and process connection wetted parts material

Materials of construction comply with recommendations per NACE® MR0175/ISO 15156 for sour oil field production environments. Environmental limits apply to certain materials. Consult latest standard for details. Selected materials also conform to NACE MR0103 for sour refining environments.

Code	Description	
2	316L SST	★
3	Alloy C-276	★

Sensor fill fluid

Code	Description	
1	Silicone	★

Code	Description	
2	Inert	★

Housing material

Code	Material	Conduit entry size	
A	Aluminum	½–14 NPT	★
B	Aluminum	M20 x 1.5	★
D	Aluminum	G½	★

Additional options

Extended product warranty

Code	Description	
WR3	3-year limited warranty	★
WR5	5-year limited warranty	★

Integral manifold assembly

“Assemble-to” items are specified separately and require a completed model number.

Code	Description	
S5	Assemble to Rosemount 306 Integral Manifold	★

Seal assemblies

“Assemble-to” items are specified separately and require a completed model number.

Code	Description	
S1	Assemble to one Rosemount 1199 Diaphragm Seal	★

Mounting bracket

Panel mounting bolts are not supplied.

Code	Description	
B4	Bracket for 2-in. pipe or panel mounting, all SST	★
BE	316 SST B4 bracket with 316 SST bolts	★

Product certifications

Consult an Emerson representative for availability of product certifications.

Code	Description	
E1	ATEX Flameproof	

Code	Description
I1	ATEX Intrinsic Safety
K1	ATEX Flameproof, Intrinsic Safety, Type n, Dust
N1	ATEX Type n
ND	ATEX Dust
E2	INMETRO Flameproof
I2	INMETRO Intrinsically Safe
K2	INMETRO Flameproof, Intrinsic Safety
E3	China Flameproof
I3	China Intrinsic Safety
N3	China Type n
E5	USA Explosion-proof, Dust Ignition-proof
I5	USA Intrinsically Safe, Division 2
K5	USA Explosion-proof, Dust Ignition-proof, Intrinsic Safety, Division 2
KB	USA and Canada Explosion-proof, Dust Ignition-proof, Intrinsic Safety, and Division 2 (combo of K5 and K6)
KD	USA, Canada and ATEX Explosion proof, Intrinsically Safety (combination of K5, K6 I1, and E1)
KL	USA, Canada, IECEx, ATEX Intrinsic Safety Combination
KS	USA, Canada, IECEx, ATEX Explosion Proof, Intrinsically Safe, Dust, Non-Incendive, Type-N, Div. 2
E6	Canada Explosion-proof, Dust Ignition-proof, Division 2
I6	Canada intrinsically Safe
K6	Canada Explosion-proof, Dust Ignition-proof, Intrinsic Safety, Division 2
KA	Canada and ATEX Explosion proof, Dust Ignition-proof, Intrinsic Safety, division (combo of E1, I1, and K6)
E7	IECEx Flameproof
I7	IECEx Intrinsic Safety
K7	IECEx Flameproof, Intrinsic Safety, Type n and Dust
N7	IECEx Type n
NK	IECEx Dust
EM	Technical Regulations Customs Union (EAC) Flameproof
IM	Technical Regulations Customs Union (EAC) Intrinsic Safety
KM	Technical Regulations Customs Union (EAC) Flame-proof, Intrinsic Safety
EP	Republic of Korea Flameproof
IP	Republic of Korea Intrinsic Safety
KP	Republic of Korea Flame-proof, Intrinsic Safety
EW	India (CCOE) Flameproof Approval
IW	India (CCOE) Intrinsic Safety

Drinking water approval

This option is not available with coned and threaded connection (2F code), assemble-to manifold (S5 code), assemble-to seal (S1 code), surface finish certification (Q16 code), remote seal system report (QZ code).

Code	Description	
DW	NSF drinking water approval	★

Pressure testing

Code	Description	
P1 ⁽¹⁾	Hydrostatic testing with certificate	★

(1) Not available with pressure range 0.

Cleaning process area

This option is not valid with alternate process connection S5.

Code	Description	
P2	Cleaning for special service	★
P3	Cleaning for < 1 ppm chlorine/fluorine	★

Calibration certification

Code	Description	
Q4	Calibration certificate	★

Material traceability certification

Code	Description	
Q8	Material traceability certification per EN 10204 3.1	★

Positive material identification (PMI)

Code	Description	
Q76	PMI verification and certificate	★

Quality certification for safety

This option is only available with 4–20 mA HART (output code A).

Code	Description	
QT	Safety certified to IEC 61508 with certificate of FMEDA	★

Configuration buttons

Code	Description	
D4	Analog zero and span	★
DZ	Digital zero trim	★

Conduit plug

Transmitter is shipped with 316 SST conduit plug (uninstalled) in place of standard CS conduit plug.

Code	Description	
DO	316 SST conduit plug	★

Ground screw

The V5 option is not needed with the T1 option; external ground screw assembly is included with the T1 option.

Code	Description	
V5	External ground screw assembly	★

Performance

High performance option includes 0.05 percent reference accuracy, and five year stability. See Performance specifications for details.

Code	Description	
P8	High performance option	★

Display and interface options

Select configuration buttons (option code D4 or DZ) if local configuration buttons are required.

Code	Description	
M4	LCD display with LOI	★
M5	LCD display	★

Transient terminal block

Code	Description	
T1	Transient protection terminal block	★

Software configuration

Code	Description	
C1	Custom software configuration (requires Rosemount 2051 Configuration Data Sheet)	★

Alarm levels

Code	Description	
C4	Analog output levels compliant with NAMUR recommendation NE 43, high alarm	★
CN	Analog output levels compliant with NAMUR recommendation NE 43, low alarm	★
CR	Custom alarm and saturation signal levels, high alarm (requires C1 and Configuration Data Sheet)	★
CS	Custom alarm and saturation signal levels, low alarm (requires C1 and Configuration Data Sheet)	★
CT	Low alarm (standard Rosemount alarm and saturation levels)	★

HART revision configuration

Only available with 4–20 mA HART® (output code A).

Code	Description	
HR5 ⁽¹⁾	Configured for HART Revision 5	★
HR7 ⁽²⁾	Configured for HART Revision 7	★

(1) Configures the HART output to HART Revision 5. The device can be field configured to HART Revision 7 if needed.

(2) Configures the HART output to HART Revision 7. The device can be field configured to HART Revision 5 if needed.

Surface finish

Code	Description	
Q16	Surface finish certification for sanitary remote seals	★

Toolkit total system performance reports

Code	Description	
QZ	Remote seal system performance calculation report	★

Conduit electrical connection

Code	Description	
GE	M12, 4-pin, male connector (eurofast®)	★
GM	A size mini, 4-pin, male connector (minifast®)	★

NACE® certificate

NACE Compliant wetted materials are identified by materials of construction that comply with recommendations per NACE MR0175/ISO 15156 for sour oil field production environments. Environmental limits apply to certain materials. Consult latest standard for details. Selected materials also conform to NACE MR0103 for sour refining).

Code	Description	
Q15	Certificate of compliance to NACE MR0175/ISO 15156 for wetted materials	★
Q25	Certificate of compliance to NACE MR0103 for wetted materials	★

SST tagging

Code	Description
Y2	316 SST nameplates, labels, tags, and fasteners

Rosemount™ 2051CF Flow Meters

Rosemount 2051CF Flow Meters combine the proven Rosemount 2051 Pressure Transmitter and the latest primary element technologies. All flow meters are fully assembled, calibrated, configured, and leak tested for out-of-the-box installation and are available with wired or wireless capabilities to meet all of your application needs.

Rosemount 2051CFA Annubar Flow Meter



Rosemount Annubar technology minimizes permanent pressure loss while delivering best in class accuracy.

- Lowest material costs for large line sizes.
- Flo-tap enables installation without process shutdown.
- Realize up to 96 percent less permanent pressure loss compared to traditional orifice plate installations.

Rosemount 2051CFC Compact Conditioning Flow Meter



Rosemount Compact Conditioning technologies provide unprecedented performance with minimal straight-run requirements. Solutions include conditioning orifice plate or Rosemount Annubar primary elements.

- Conditioning orifice requires only two pipe diameters upstream and downstream.
- Eliminate swirl and regular profiles resulting in more stable and accurate flow measurement.
- Savings up to 55 percent when compared to a traditional orifice plate installation can be realized.

Rosemount 2051CFP Integral Orifice Flow Meter



Rosemount Integral Orifice Flow Meters deliver highly accurate small-bore flow measurement capability with minimal installation and maintenance requirements.

- Best performance for small line sizes ½- to 1½-in. (15 to 40 mm).
- Precision honed pipe section and tight machining tolerances deliver higher installed performance.
- Reduces uncertainty by up to five percent compared to traditional orifice plate installation.

Rosemount CFA Annubar™ ordering information



- Patented T-shape Annubar creates a fixed separation point for DP signal improvement over a wider flow rate
- Complete flow assemblies are leak-tested and calibrated to reduce leak points up to 70 percent and simplify installation
- T-shape design of averaging pitot tube ensures very low permanent pressure loss
- Local operator interface offers easy-to-use menus and built-in configuration buttons for streamlined commissioning
- Sensor stagnation zone positioned to reduce noise, measurement inaccuracies and keeps particulates from clogging
- SIL 2/3 certified to IEC 61508 (via 3rd party) and prior-use certificate of FMEDA data for safety installations

[VIEW PRODUCT >](#)

Online product configurator

Many products are configurable online using our Product Configurator. Select the **Configure** button or visit our [website](#) to start. With this tool's built-in logic and continuous validation, you can configure your products more quickly and accurately.

Specifications and options

See the Specifications and options section for more details on each configuration. Specification and selection of product materials, options, or components must be made by the purchaser of the equipment. See the Material selection section for more information.

Model codes

Model codes contain the details related to each product. Exact model codes will vary; an example of a typical model code is shown in Figure 4.

Figure 4: Model Code Example

3051C D 2 X 2 2 M5 B4

1 2

1. Required model components (choices available on most)
2. Additional options (variety of features and functions that may be added to products)

Optimizing lead time

The starred offerings (★) represent the most common options and should be selected for best delivery. The non-starred offerings are subject to additional delivery lead time.

Required model components

Model

Code	Description	
2051CFA	Annubar Flow Meter	★

Measurement type

Code	Description	
D	Differential	★

Fluid type

Code	Description	
L	Liquid	★
G	Gas	★
S	Steam	★

Line size

Code	Description	
020	2-in. (50 mm)	★
025	2½-in. (63.5 mm)	★
030	3-in. (80 mm)	★
035	3½-in. (89 mm)	★

040	4-in. (100 mm)	★
050	5-in. (125 mm)	★
060	6-in. (150 mm)	★
070	7-in. (175 mm)	★
080	8-in. (200 mm)	★
100	10-in. (250 mm)	★
120	12-in. (300 mm)	★

Pipe I.D. range

See the Rosemount DP Flow Meters and Primary Elements [Product Data Sheet](#) for pipe I.D. table.

Code	Description	
Z	Custom manufactured for customer's supplied pipe ID	

Pipe and mounting assembly material

Code	Description	
C	CS (A105)	★
S	316 SST	★
0 ⁽¹⁾	No mounting (customer supplied)	
G	Chrome-moly grade F-11	
N	Chrome-moly grade F-22	
J	Chrome-moly grade F-91	

(1) Provide the "A" dimension for flanged and pak-lok shown in "Dimensional drawings" section.

Pipe orientation

Code	Description	
H	Horizontal piping	★
D	Vertical piping with downward flow	★
U	Vertical piping with upward flow	★

Rosemount Annubar type

Code	Description	
P	Pak-lok	★
F	Flanged with opposite side support	★

Sensor material

Code	Description	
S	316 SST	★

Sensor size

Code	Description	
1	Sensor size 1 — line sizes 2- to 8-in. (50 to 200 mm)	★
2	Sensor size 2 — line sizes 6- to 96-in. (150 to 2400 mm)	★
3	Sensor size 3 — line sizes greater than 12-in. (300 mm)	★

Mounting type

Code	Description	
T1	Compression or threaded connection	★
A1	Class 150 RF ASME B16.5	★
A3	Class 300 RF ASME B16.5	★
A6	Class 600 RF ASME B16.5	★
D1	PN16 EN-1092-1 RF	★
D3	PN40 EN-1092-1 RF	★
D6	PN100 EN-1092-1 RF	★
R1	Class 150 RTJ ASME B16.5	
R3	Class 300 RTJ ASME B16.5	
R6	Class 600 RTJ ASME B16.5	

Opposite side support or packing gland

Code	Description	
0	No opposite side support or packing gland (required for pak-lok models)	★

Opposite side support (required for flanged models)

Code	Description	
C	NPT threaded opposite support assembly — extended tip	★
D	Welded opposite support assembly — extended tip	★

Isolation valve

Provide the "A" dimension for flanged and pak-lok shown in "Dimensional drawings" section.

Code	Description	
0	Not applicable or customer supplied	★

Temperature measurement

Code	Description	
T	Integral RTD — not available with flanged model greater than Class 600	★

0	No temperature sensor	★
R	Remote thermowell and RTD	

Transmitter connection platform

Code	Description	
3	Direct mount, Integral 3-valve manifold — not available with flanged model greater than Class 600	★
5	Direct mount, 5-valve manifold — not available with flanged model greater than Class 600	★
7	Remote mount NPT connections (½-in. FNPT)	★
8	Remote mount SW connections (½-in.)	

Differential pressure range

Code	Description	
1	0 to 25 inH ₂ O (0 to 62.16 mbar)	★
2	0 to 250 inH ₂ O (0 to 621.6 mbar)	★
3	0 to 1000 inH ₂ O (0 to 2.49 bar)	★

Transmitter output

Code	Description	
A ⁽¹⁾	4–20 mA with digital signal based on HART® Protocol	★
F	FOUNDATION™ Fieldbus Protocol	★
W ⁽²⁾	PROFIBUS® PA Protocol	★
X ⁽³⁾	Wireless	★
M ⁽⁴⁾	Low-power, 1–5 Vdc with digital signal based on HART Protocol	

(1) HART Revision 5 is the default HART output. The Rosemount 2051 with Selectable HART can be factory or field configured to HART Revision 7. To order HART Revision 7 factory configured, add option code HR7.

(2) For local addressing and configuration, M4 (LOI) is required. Not available with product certification codes E4, EM, EP, I6, IM, KD, KL, KM, KP, KS, N3

(3) Only available with intrinsically safe approvals.

(4) Only available with Housing Codes A and J and with C6, E2,E5, I5, K5, EM, EP, KB, and E8 product certifications.

Transmitter housing material

Code	Description	Conduit entry size	
A	Aluminum	½–14 NPT	★
B	Aluminum	M20 x 1.5	★
E	Aluminum, ultra low copper	½–14 NPT	★
F	Aluminum, ultra low copper	M20 x 1.5	★
J	SST	½–14 NPT	★
K	SST	M20 x 1.5	★
p ⁽¹⁾	Engineered polymer	No conduit entries	★

Code	Description	Conduit entry size	
D ⁽²⁾	Aluminum	G½	
M ⁽²⁾	SST	G½	

(1) Only available with output code X.

(2) Transmitter conduit entry will be ½ NPT and a ½ NPT to G½ thread adapter will be provided. This option is only available with product certifications options I1, I2, I3, I7, IA, IB, IM, KA, N1, N3, N7. Housing code D is also available with E4, and IG.

Transmitter performance class

Code	Description	
1	2.0% flow rate accuracy, 5:1 flow turndown, 2-year stability	★

Wireless options

Requires wireless output code X and engineered polymer housing code P.

Wireless transmit rate, operating frequency, and protocol

Code	Description	
WA3	User configurable transmit rate, 2.4 GHz WirelessHART ®	★

Antenna and SmartPower™

Code	Description	
WP5	Internal antenna, compatible with Green Power Module (I.S. Power Module sold separately)	★

Additional options

Extended product warranty

Code	Description	
WR3	3-year limited warranty	★
WR5	5-year limited warranty	★

Special cleaning

This option is not available with low power (output code M).

Code	Description	
P2	Cleaning for special processes	

Material testing

Not available with low power (output code M).

Code	Description	
V1	Dye penetrant exam	

Material examination

Not available with low power (output code M).

Code	Description	
V2	Radiographic examination	

Special inspection

Not available with low power (output code M).

Code	Description	
QC1	Visual and dimensional inspection with certificate	★
QC7	Inspection and performance certificate	★

Surface finish

Not available with low power (output code M).

Code	Description	
RL	Surface finish for low pipe Reynolds number in gas and steam	★
RH	Surface finish for high pipe Reynolds number in liquid	★

Material traceability certification

This option is not available with low power (output code M).

This option is only valid with FOUNDATION™ Fieldbus (output code F).

Code	Description	
Q8	Material traceability certification per EN 10474:2004 3.1	★

Positive material identification (PMI)

Code	Description	
Q76	PMI verification and certificate	★

Code conformance

This option is not available with low power (output code M).

Code	Description	
J2	ANSI/ASME B31.1	
J3	ANSI/ASME B31.3	

Materials conformance

This option is not available with low power (output code M).

This option is only valid with FOUNDATION™ Fieldbus (output code F).

Code	Description	
J5	NACE MR-0175/ISO 15156	

Country certification

This option is not available with low power (output code M).

Code	Description	
J6	European Pressure Directive (PED)	★
J1	Canadian registration	

Instrument connections for remote mount options

This option is not available with low power (output code M).

Code	Description	
G2	Needle valves, SST	★
G6	OS&Y gate valve, SST	★
G1	Needle valves, CS	
G3	Needle valves, alloy C-276	
G5	OS&Y gate valve, CS	
G7	OS&Y gate valve, alloy C-276	

Special shipment

This option is not available with low power (output code M).

Code	Description	
Y1	Mounting hardware shipped separately	★

Product certifications

Code	Description	
E8	ATEX Flameproof and Dust Certification	★
I1 ⁽¹⁾	ATEX Intrinsic Safety and Dust	★
IA	ATEX FISCO Intrinsic Safety; for FOUNDATION™ Fieldbus or PROFIBUS® PA Protocol only	★
N1	ATEX Type n Certification and Dust	★
K8	ATEX Flameproof, Intrinsic Safety, Type n, Dust (combination of E8, I1 and N1)	★
E4	TIIS Flame-proof	★
I4	TIIS Intrinsic Safety	★
E5	USA Explosion-proof, Dust Ignition-Proof	★

I5 ⁽²⁾	USA Intrinsically Safe, Nonincendive	★
C6	Canada Explosion-proof, Dust Ignition-proof, Intrinsically Safe, and Division 2	★
E6	Canada Explosion-proof, Dust Ignition-proof, Division 2	★
I6	Canada Intrinsic Safety	★
K6	Canada and ATEX Explosion-proof, Intrinsically Safe, and Division 2 (combination of C6, E8, and I1)	★
E7	IECEX Flameproof, Dust Ignition-proof	★
I7	IECEX Intrinsic Safety	★
N7	IECEX Type n Certification	★
K7	IECEX Flame-proof, Dust Ignition-proof, Intrinsic Safety, and Type n (combination of I7, N7, and E7)	★
IG	IECEX FISCO Intrinsically Safe; for FOUNDATION Fieldbus or PROFIBUS PA Protocols only	★
K5	USA Explosion-proof, Dust Ignition-Proof, Intrinsically Safe, and Division 2	★
E2	INMETRO Flameproof001	★
I2	INMETRO Intrinsic Safety	★
IB	INMETRO FISCO intrinsically safe; for FOUNDATION Fieldbus or PROFIBUS PA Protocols only	★
K2	INMETRO Flameproof, Intrinsic Safety	★
E3	China Flameproof	★
I3	China Intrinsic Safety	★
N3	China Type n	★
EM	Technical Regulations Customs Union (EAC) Flameproof	★
IM	Technical Regulations Customs Union (EAC) Intrinsic Safety	★
KM	Technical Regulations Customs Union (EAC) Flameproof and Intrinsic Safety	★
KB	USA and Canada Explosion-proof, Dust Ignition Proof, Intrinsically Safe, and Division 2 (combination of K5 and C6)	★
KD	USA, Canada, and ATEX Explosion-proof, Intrinsically Safe (combination of K5, C6, I1, and E8)	★
KL ⁽³⁾	USA, Canada, IECEX, ATEX Intrinsic Safety Combination	★
KS	USA, Canada, IECEX, ATEX Explosion Proof, Intrinsically Safe, Dust, Non-Incendive, Type-N, Div. 2	★
EP	Republic of Korea Flameproof	★
IP	Republic of Korea Intrinsic Safety	★
KP	Republic of Korea Flameproof, Intrinsic Safety	★

(1) Dust approval not applicable to output code X.

(2) Nonincendive certification not provided with output code (X).

(3) Only available with output code X.

Sensor fill fluid and O-ring options

This option is not available with low power (output code M).

Code	Description	
L1 ⁽¹⁾	Inert sensor fill fluid	★
L2	Graphite-filled (PTFE) O-ring	★

LA ⁽¹⁾	Inert sensor fill fluid and graphite-filled (PTFE) O-ring	★
-------------------	---	---

(1) Not available with output code X.

Display and interface options

This option is not available with low power (output code M).

Code	Description	
M4 ⁽¹⁾	LCD display with LOI	★
M5	LCD display	★

(1) Not available with FOUNDATION™ Fieldbus (output code F) or wireless (output code X).

Transmitter calibration certification

This option is not available with low power (output code M).

Code	Description	
Q4	Calibration certificate for transmitter	★

Quality certification for safety

The quality certification for safety is only available with HART® 4–20 mA output (code A).

Code	Description	
QT	Safety certified to IEC 61508 with certificate of FMEDA	★

Transient protection

This option is not available with low power (output code M).

This option is not available with output code X.

This option is not available with housing code 00, 5A, or 7J. The T1 option is not needed with FISCO Product Certifications, transient protection is included with the FISCO Product Certification code IA.

Code	Description	
T1	Transient terminal block	★

Manifold for remote mount option

This option is not available with low power (output code M).

Code	Description	
F2	3-valve manifold, SST	★
F6	5-valve manifold, SST	★

Configuration buttons

This option is not available with low power (output code M).

Code	Description	
D4 ⁽¹⁾	Zero and span hardware adjustments	★
DZ ⁽²⁾	Digital zero trim	★

(1) Only available with 4–20 mA HART® (output codes A and M).

(2) Only available with 4–20 mA HART (output codes A and M) and wireless output (code X).

Alarm limit

This option is not available with low power (output code M).

This option is only available with 4–20 mA HART® (output codes A and M).

Code	Description	
C4	NAMUR alarm and saturation levels, high alarm	★
CN	NAMUR alarm and saturation levels, low alarm	★
CR	Custom alarm and saturation signal levels, high alarm (requires C1 and Configuration Data Sheet)	★
CS	Custom alarm and saturation signal levels, low alarm (requires C1 and Configuration Data Sheet)	★
CT	Low alarm (standard Rosemount alarm and saturation levels)	★

Ground screw

This option is not available with low power (output code M).

This option is not available with output code X.

The V5 option is not needed with the T1 option; external ground screw assembly is included with the T1 option.

Code	Description	
V5	External ground screw assembly	★

HART revision configuration

This option is not available with low power (output code M).

This option is only available with 4–20 mA HART® (output codes A and M).

Code	Description	
HR5 ⁽¹⁾	Configured for HART Revision 5	★
HR7 ⁽²⁾	Configured for HART Revision 7	★

(1) Configures the HART output to HART Revision 5. The device can be field configured to HART Revision 7 if needed.

(2) Configures the HART output to HART Revision 7. The device can be field configured to HART Revision 5 if needed.

Rosemount 2051CFC Compact Flow Meter ordering information



- Complete flow assemblies are leak-tested and calibrated to reduce leak points up to 70% and simplify installation
- Primary element design delivers reliable and accurate flow measurement for gas, liquid and steam service
- Orifice plate available in 0.5 - 12 in. (15 - 300 mm) line sizes for application flexibility
- Local operator interface offers easy-to-use menus and built-in configuration buttons for streamlined commissioning
- SIL 2/3 certified to IEC 61508 (via 3rd party) and prior-use certificate of FMEDA data for safety installations

[VIEW PRODUCT >](#)

Online product configurator

Many products are configurable online using our Product Configurator. Select the **Configure** button or visit our [website](#) to start. With this tool's built-in logic and continuous validation, you can configure your products more quickly and accurately.

Specifications and options

See the Specifications and options section for more details on each configuration. Specification and selection of product materials, options, or components must be made by the purchaser of the equipment. See the Material selection section for more information.

Model codes

Model codes contain the details related to each product. Exact model codes will vary; an example of a typical model code is shown in [Figure 5](#).

Figure 5: Model Code Example

3051C D 2 X 2 2 M5 B4

1 2

1. Required model components (choices available on most)
2. Additional options (variety of features and functions that may be added to products)

Optimizing lead time

The starred offerings (★) represent the most common options and should be selected for best delivery. The non-starred offerings are subject to additional delivery lead time.

Required model components

Model

Code	Description	
2051CFC	Compact flow meter	★

Measurement type

Code	Description	
D	Differential	★

Primary element technology

Code	Description	
A	Rosemount Annubar™ averaging pitot tube	
C	Conditioning orifice plate	★
P	Orifice plate	★

Material type

Code	Description	
S	316 SST	★

Line size

Code	Description	
005 ⁽¹⁾	½-in. (15 mm)	★
010 ⁽¹⁾	1-in. (25 mm)	★
015 ⁽¹⁾	1½-in. (40 mm)	★
020	2-in. (50 mm)	★
030	3-in. (80 mm)	★
040	4-in. (100 mm)	★
060	6-in. (150 mm)	★
080	8-in. (200 mm)	★
100 ⁽²⁾⁽³⁾	10-in. (250 mm)	★
120 ⁽¹⁾⁽³⁾	12-in. (300 mm)	★

(1) Not available for primary element technology C.

(2) For the 10- and 12-in. (250 and 300 mm) line size, the alignment ring must be ordered (installation accessories).

(3) 10- and 12-in. (250 and 300 mm) line sizes not available with primary element technology A.

Primary element type

Code	Description	
N000	Rosemount Annubar sensor size 1	★
N040	0.40 beta ratio	★
N050	0.50 beta ratio	★
N065 ⁽¹⁾	0.65 beta ratio	★

(1) For 2-in. (50 mm) line sizes the primary element type is 0.6 for primary element technology code C.

Temperature measurement

Code	Description	
0	No temperature sensor	★
T ⁽¹⁾	Integral RTD	
R	Remote thermowell and RTD	

(1) Available with primary element technology A only.

Transmitter connection platform

Code	Description	
3	Direct mount	★
7	Remote mount, NPT connections	★

Differential pressure range

Code	Description	
1	0 to 25 inH ₂ O (0 to 62.16 mbar)	★
2	0 to 250 inH ₂ O (0 to 621.6 mbar)	★
3	0 to 1000 inH ₂ O (0 to 2.49 bar)	★

Transmitter output

Code	Description	
A ⁽¹⁾	4–20 mA with digital signal based on HART [®] Protocol	★
F	FOUNDATION [™] Fieldbus Protocol	★
W ⁽²⁾	PROFIBUS [®] PA Protocol	★
X ⁽³⁾	Wireless	★
M ⁽⁴⁾	Low-power, 1–5 Vdc with digital signal based on HART Protocol	

(1) HART Revision 5 is the default HART output. The Rosemount 2051 with Selectable HART can be factory or field configured to HART Revision 7. To order HART Revision 7 factory configured, add option code HR7.

(2) For local addressing and configuration, M4 (LOI) is required. Not available with product certification codes E4, EM, EP, I6, IM, KD, KL, KM, KP, KS, N3

(3) Only available with intrinsically safe approvals.

(4) Only available with Housing Codes A and J and with C6, E2, E5, I5, K5, EM, EP, KB, and E8 product certifications.

Transmitter housing material

Code	Description	Conduit entry size	
A	Aluminum	½–14 NPT	★
B	Aluminum	M20 x 1.5	★
E	Aluminum, ultra low copper	½–14 NPT	★
F	Aluminum, ultra low copper	M20 x 1.5	★
J	SST	½–14 NPT	★
K	SST	M20 x 1.5	★
P ⁽¹⁾	Engineered polymer	No conduit entries	★
D ⁽²⁾	Aluminum	G½	
M ⁽²⁾	SST	G½	

(1) Only available with output code X.

(2) Transmitter conduit entry will be ½ NPT and a ½ NPT to G½ thread adapter will be provided. This option is only available with product certifications options I1, I2, I3, I7, IA, IB, IM, KA, N1, N3, N7. Housing code D is also available with E4, and IG.

Transmitter performance class

Code	Description	
1	Up to ±2.25% flow rate accuracy, 5:1 flow turndown, 2-year stability	★

Wireless options

Requires wireless output code X and engineered polymer housing code P.

Wireless transmit rate, operating frequency, and protocol

Code	Description	
WA3	User configurable transmit rate, 2.4 GHz WirelessHART ®	★

Antenna and SmartPower™

Code	Description	
WP5	Internal antenna, compatible with Green Power Module (I.S. Power Module sold separately)	★

Additional options

Extended product warranty

Code	Description	
WR3	3-year limited warranty	★
WR5	5-year limited warranty	★

Installation accessories

This option is not available with low power (output code M).

Code	Description	
AB	ANSI alignment ring (Class 150) (only required for 10- and 12-in. [250 and 300 mm] line sizes)	★
AC	ANSI alignment ring (Class 300) (only required for 10- and 12-in. [250 and 300 mm] line sizes)	★
AD	ANSI alignment ring (Class 600) (only required for 10- and 12-in. [250 and 300 mm] line sizes)	★
DG	DIN alignment ring (PN 16)	★
DH	DIN alignment ring (PN 40)	★
DJ	DIN alignment ring (PN 100)	★
JB	JIS alignment ring (10K)	
JR	JIS alignment ring (20K)	
JS	JIS alignment ring (40K)	

Remote adapters

This option is not available with low power (output code M).

Code	Description	
FE	Flange adapters 316 SST (½-in. NPT)	★

High temperature application

This option is not available with low power (output code M).

Code	Description	
HT	Graphite valve packing ($T_{max} = 850\text{ }^{\circ}\text{F}$)	

Flow calibration

This option is not available with low power (output code M).

This option is not available with primary element technology P.

Code	Description	
WC	Flow calibration, 3 Pt, conditioning orifice option C (all pipe schedules)	
WD	Flow calibration, 10 Pt, conditioning option C (all schedules), Rosemount Annubar option A (schedule 40)	

Pressure testing

This option is not available with low power (output code M).

Code	Description	
P1	Hydrostatic testing with certificate	

Special cleaning

This option is not available with low power (output code M).

Code	Description	
P2	Cleaning for special processes	

Special inspection

Not available with low power (output code M).

Code	Description	
QC1	Visual and dimensional inspection with certificate	★
QC7	Inspection and performance certificate	★

Transmitter calibration certification

This option is not available with low power (output code M).

Code	Description	
Q4	Calibration certificate for transmitter	★

Quality certification for safety

The quality certification for safety is only available with HART® 4–20 mA output (code A).

Code	Description	
QT	Safety certified to IEC 61508 with certificate of FMEDA	★

Material traceability certification

This option is not available with low power (output code M).

Code	Description	
Q8	Material traceability certification per EN 10204:2004 3.1	★

Positive material identification (PMI)

Code	Description	
Q76	PMI verification and certificate	★

Code conformance

This option is not available with low power (output code M).

Code	Description	
J2	ANSI/ASME B31.1	
J3	ANSI/ASME B31.3	
J4	ANSI/ASME B31.8	

Materials conformance

This option is not available with low power (output code M).

Materials of Construction comply with metallurgical requirements within NACE MR0175/ISO for sour oil field production environments. Environmental limits apply to certain materials. Consult latest standard for details. Selected materials also conform to NACE MR0103 for sour refining environments.

Code	Description	
J5	NACE MR-0175/ISO 15156	

Country certification

This option is not available with low power (output code M).

Code	Description	
J1	Canadian registration	

Product certifications

Code	Description	
E8	ATEX Flameproof and Dust Certification	★
I1 ⁽¹⁾	ATEX Intrinsic Safety and Dust	★
IA	ATEX FISCO Intrinsic Safety; for FOUNDATION™ Fieldbus or PROFIBUS® PA Protocol only	★
N1	ATEX Type n Certification and Dust	★
K8	ATEX Flameproof, Intrinsic Safety, Type n, Dust (combination of E8, I1 and N1)	★
E4	TIIS Flame-proof	★
I4	TIIS Intrinsic Safety	★
E5	USA Explosion-proof, Dust Ignition-Proof	★
I5 ⁽²⁾	USA Intrinsically Safe, Nonincendive	★
C6	Canada Explosion-proof, Dust Ignition-proof, Intrinsically Safe, and Division 2	★
E6	Canada Explosion-proof, Dust Ignition-proof, Division 2	★
I6	Canada Intrinsic Safety	★
K6	Canada and ATEX Explosion-proof, Intrinsically Safe, and Division 2 (combination of C6, E8, and I1)	★
E7	IECEX Flameproof, Dust Ignition-proof	★
I7	IECEX Intrinsic Safety	★
N7	IECEX Type n Certification	★
K7	IECEX Flame-proof, Dust Ignition-proof, Intrinsic Safety, and Type n (combination of I7, N7, and E7)	★
IG	IECEX FISCO Intrinsically Safe; for FOUNDATION Fieldbus or PROFIBUS PA Protocols only	★
K5	USA Explosion-proof, Dust Ignition-Proof, Intrinsically Safe, and Division 2	★
E2	INMETRO Flameproof001	★
I2	INMETRO Intrinsic Safety	★
IB	INMETRO FISCO intrinsically safe; for FOUNDATION Fieldbus or PROFIBUS PA Protocols only	★

K2	INMETRO Flameproof, Intrinsic Safety	★
E3	China Flameproof	★
I3	China Intrinsic Safety	★
N3	China Type n	★
EM	Technical Regulations Customs Union (EAC) Flameproof	★
IM	Technical Regulations Customs Union (EAC) Intrinsic Safety	★
KM	Technical Regulations Customs Union (EAC) Flameproof and Intrinsic Safety	★
KB	USA and Canada Explosion-proof, Dust Ignition Proof, Intrinsically Safe, and Division 2 (combination of K5 and C6)	★
KD	USA, Canada, and ATEX Explosion-proof, Intrinsically Safe (combination of K5, C6, I1, and E8)	★
KL ⁽³⁾	USA, Canada, IECEx, ATEX Intrinsic Safety Combination	★
KS	USA, Canada, IECEx, ATEX Explosion Proof, Intrinsically Safe, Dust, Non-Incendive, Type-N, Div. 2	★
EP	Republic of Korea Flameproof	★
IP	Republic of Korea Intrinsic Safety	★
KP	Republic of Korea Flameproof, Intrinsic Safety	★

(1) Dust approval not applicable to output code X.

(2) Nonincendive certification not provided with output code (X).

(3) Only available with output code X.

Sensor fill fluid and O-ring options

This option is not available with low power (output code M).

Code	Description	
L1 ⁽¹⁾	Inert sensor fill fluid	★
L2	Graphite-filled (PTFE) O-ring	★
LA ⁽¹⁾	Inert sensor fill fluid and graphite-filled (PTFE) O-ring	★

(1) Not available with output code X.

Display and interface options

This option is not available with low power (output code M).

Code	Description	
M4 ⁽¹⁾	LCD display with LOI	★
M5	LCD display	★

(1) Not available with FOUNDATION™ Fieldbus (output code F) or wireless (output code X).

Transient protection

This option is not available with low power (output code M).

This option is not available with output code X.

This option is not available with housing code 00, 5A, or 7J. The T1 option is not needed with FISCO Product Certifications, transient protection is included with the FISCO Product Certification code IA.

Code	Description	
T1	Transient terminal block	★

Manifold for remote mount option

This option is not available with low power (output code M).

Code	Description	
F2	3-valve manifold, SST	★
F6	5-valve manifold, SST	★

Alarm limit

This option is not available with low power (output code M).

This option is only available with 4–20 mA HART® (output codes A and M).

Code	Description	
C4	NAMUR alarm and saturation levels, high alarm	★
CN	NAMUR alarm and saturation levels, low alarm	★
CR	Custom alarm and saturation signal levels, high alarm (requires C1 and Configuration Data Sheet)	★
CS	Custom alarm and saturation signal levels, low alarm (requires C1 and Configuration Data Sheet)	★
CT	Low alarm (standard Rosemount alarm and saturation levels)	★

Plantweb control functionality

This option is not available with low power (output code M).

This option is only valid with FOUNDATION™ Fieldbus (output code F).

Code	Description	
A01	FOUNDATION Fieldbus advanced control function block suite	★

Configuration buttons

This option is not available with low power (output code M).

Code	Description	
D4 ⁽¹⁾	Zero and span hardware adjustments	★
DZ ⁽²⁾	Digital zero trim	★

(1) Only available with 4–20 mA HART® (output codes A and M).

(2) Only available with 4–20 mA HART (output codes A and M) and wireless output (code X).

Ground screw

This option is not available with low power (output code M).

This option is not available with output code X.

The V5 option is not needed with the T1 option; external ground screw assembly is included with the T1 option.

Code	Description	
V5	External ground screw assembly	★

HART revision configuration

This option is not available with low power (output code M).

This option is only available with 4–20 mA HART® (output codes A and M).

Code	Description	
HR5 ⁽¹⁾	Configured for HART Revision 5	★
HR7 ⁽²⁾	Configured for HART Revision 7	★

(1) Configures the HART output to HART Revision 5. The device can be field configured to HART Revision 7 if needed.

(2) Configures the HART output to HART Revision 7. The device can be field configured to HART Revision 5 if needed.

Rosemount 2051CFP Integral Orifice Flow Meter ordering information



- Complete flow assemblies are leak-tested and calibrated to reduce leak points up to 70 percent and simplify installation
- Primary element integrated in a meter run for ease of installation
- Orifice plate suitable for small line sizes 0.5- 1.5 in. (15 - 40 mm) for flow measurement accuracy and repeatability
- Local operator interface offers easy-to-use menus and built-in configuration buttons for streamlined commissioning
- SIL 2/3 certified to IEC 61508 (via 3rd party) and prior-use certificate of FMEDA data for safety installations

[VIEW PRODUCT >](#)

Online product configurator

Many products are configurable online using our Product Configurator. Select the **Configure** button or visit our [website](#) to start. With this tool's built-in logic and continuous validation, you can configure your products more quickly and accurately.

Specifications and options

See the Specifications and options section for more details on each configuration. Specification and selection of product materials, options, or components must be made by the purchaser of the equipment. See the Material selection section for more information.

Model codes

Model codes contain the details related to each product. Exact model codes will vary; an example of a typical model code is shown in [Figure 6](#).

Figure 6: Model Code Example

3051C D 2 X 2 2 M5 B4
1 2

1. Required model components (choices available on most)
2. Additional options (variety of features and functions that may be added to products)

Optimizing lead time

The starred offerings (★) represent the most common options and should be selected for best delivery. The non-starred offerings are subject to additional delivery lead time.

Required model components

Model

Code	Description	
2051CFP	Integral orifice flow meter	★

Measurement type

Code	Description	
D	Differential	★

Material type

Code	Description	
S	316 SST	★

Line size

Code	Description	
005	½-in. (15 mm)	★
010	1-in. (25 mm)	★
015	1½-in. (40 mm)	★

Process connections

Code	Description	
T1	NPT female body (not available with thermowell and RTD)	★
S1 ⁽¹⁾	Socket weld body (not available with thermowell and RTD)	★
P1	Pipe ends: NPT threaded	★
P2	Pipe ends: beveled	★
D1	Pipe ends: flanged, PN16 EN-1092-1 RF, slip-on	★
D2	Pipe ends: flanged, PN40 EN-1092-1 RF, slip-on	★
D3	Pipe ends: flanged, PN100 EN-1092-1 RF, slip-on	★
W1	Pipe ends: flanged, RF, Class 150 RF ASME B16.5, weld-neck	★
W3	Pipe ends: flanged, RF, Class 300 RF ASME B16.5, weld-neck	★
W6	Pipe ends: flanged, RF, Class 600 RF ASME B16.5, weld-neck	★
A1	Pipe ends: flanged, Class 150 RF ASME B16.5, slip-on	
A3	Pipe ends: flanged, Class 300 RF ASME B16.5, slip-on	
A6	Pipe ends: flanged, Class 600 RF ASME B16.5, slip-on	
R1	Pipe ends: flanged, Class 150 RTJ ASME B16.5, slip-on	

Code	Description	
R3	Pipe ends: flanged, Class 300 RTJ ASME B16.5, slip-on	
R6	Pipe ends: flanged, Class 600 RTJ ASME B16.5, slip-on	

(1) To improve pipe perpendicularity for gasket sealing, socket diameter is smaller than standard pipe O.D.

Orifice plate material

Code	Description	
S	316 SST	★

Bore size

Code	Description	
0066	0.066-in. (1,68 mm) for ½-in. pipe	★
0109	0.109-in. (2,77 mm) for ½-in. pipe	★
0160	0.160-in. (4,06 mm) for ½-in. pipe	★
0196	0.196-in. (4,98 mm) for ½-in. pipe	★
0260	0.260-in. (6,60 mm) for ½-in. pipe	★
0340	0.340-in. (8,64 mm) for ½-in. pipe	★
0150	0.150-in. (3,81 mm) for 1-in. pipe	★
0250	0.250-in. (6,35 mm) for 1-in. pipe	★
0345	0.345-in. (8,76 mm) for 1-in. pipe	★
0500	0.500-in. (12,70 mm) for 1-in. pipe	★
0630	0.630-in. (16,00 mm) for 1-in. pipe	★
0800	0.800-in. (20,32 mm) for 1-in. pipe	★
0295	0.295-in. (7,49 mm) for 1½-in. pipe	★
0376	0.376-in. (9,55 mm) for 1½-in. pipe	★
0512	0.512-in. (13,00 mm) for 1½-in. pipe	★
0748	0.748-in. (19,00 mm) for 1½-in. pipe	★
1022	1.022-in. (25,96 mm) for 1½-in. pipe	★
1184	1.184-in. (30,07 mm) for 1½-in. pipe	★
0010	0.010-in. (0,25 mm) for ½-in. pipe	
0014	0.014-in. (0,36 mm) for ½-in. pipe	
0020	0.020-in. (0,51 mm) for ½-in. pipe	
0034	0.034-in. (0,86 mm) for ½-in. pipe	

Transmitter connection platform

Code	Description	
D3	Direct mount, 3-valve manifold, SST	★
D5	Direct mount, 5-valve manifold, SST	★
R3	Remote mount, 3-valve manifold, SST	★
R5	Remote mount, 5-valve manifold, SST	★

Differential pressure range

Code	Description	
1	0 to 25 inH ₂ O (0 to 62.16 mbar)	★
2	0 to 250 inH ₂ O (0 to 621.6 mbar)	★
3	0 to 1000 inH ₂ O (0 to 2.49 bar)	★

Transmitter output

Code	Description	
A ⁽¹⁾	4–20 mA with digital signal based on HART® Protocol	★
F	FOUNDATION™ Fieldbus Protocol	★
W ⁽²⁾	PROFIBUS® PA Protocol	★
X ⁽³⁾	Wireless	★
M ⁽⁴⁾	Low-power, 1–5 Vdc with digital signal based on HART Protocol	

- (1) HART Revision 5 is the default HART output. The Rosemount 2051 with Selectable HART can be factory or field configured to HART Revision 7. To order HART Revision 7 factory configured, add option code HR7.
- (2) For local addressing and configuration, M4 (LOI) is required. Not available with product certification codes E4, EM, EP, I6, IM, KD, KL, KM, KP, KS, N3
- (3) Only available with intrinsically safe approvals.
- (4) Only available with Housing Codes A and J and with C6, E2, E5, I5, K5, EM, EP, KB, and E8 product certifications.

Transmitter housing material

Code	Description	Conduit entry size	
A	Aluminum	½–14 NPT	★
B	Aluminum	M20 x 1.5	★
E	Aluminum, ultra low copper	½–14 NPT	★
F	Aluminum, ultra low copper	M20 x 1.5	★
J	SST	½–14 NPT	★
K	SST	M20 x 1.5	★
P ⁽¹⁾	Engineered polymer	No conduit entries	★
D ⁽²⁾	Aluminum	G½	
M ⁽²⁾	SST	G½	

- (1) Only available with output code X.

(2) Transmitter conduit entry will be ½ NPT and a ½ NPT to G½ thread adapter will be provided. This option is only available with product certifications options I1, I2, I3, I7, IA, IB, IM, KA, N1, N3, N7. Housing code D is also available with E4, and IG.

Transmitter performance class

Code	Description	
1	Up to ±2.25% flow rate accuracy, 5:1 flow turndown, 2-year stability	★

Wireless options

Requires wireless output code X and engineered polymer housing code P.

Wireless transmit rate, operating frequency, and protocol

Code	Description	
WA3	User configurable transmit rate, 2.4 GHz <i>WirelessHART</i> ®	★

Antenna and SmartPower™

Code	Description	
WP5	Internal antenna, compatible with Green Power Module (I.S. Power Module sold separately)	★

Additional options

Extended product warranty

Code	Description	
WR3	3-year limited warranty	★
WR5	5-year limited warranty	★

Temperature sensor

This option is not available with low power (output code M). Thermowell material is the same as the body material.

Code	Description	
RT	Thermowell and RTD	

Optional connection

This option is not available with low power (output code M).

Code	Description	
G1	DIN 19213 transmitter connection	★

Pressure testing

This option is not available with low power (output code M).

This option does not apply to process connection codes T1 and S1.

Code	Description	
P1	Hydrostatic testing with certificate	

Special cleaning

This option is not available with low power (output code M).

Code	Description	
P2	Cleaning for special processes	

Material testing

Not available with low power (output code M).

Code	Description	
V1	Dye penetrant exam	

Material examination

Not available with low power (output code M).

Code	Description	
V2	Radiographic examination	

Flow calibration

This option is not available with low power (output code M).

This option is not available for bore sizes 0010, 0014, 0020, or 0034.

Code	Description	
WD	Discharge coefficient verification	

Special inspection

Not available with low power (output code M).

Code	Description	
QC1	Visual and dimensional inspection with certificate	★
QC7	Inspection and performance certificate	★

Material traceability certification

This option is not available with low power (output code M).

Code	Description	
Q8	Material traceability certification per EN 10204:2004 3.1	★

Positive material identification (PMI)

Code	Description	
Q76	PMI verification and certificate	★

Code conformance

This option is not available with low power (output code M).

This option is not available with DIN process connection codes D1, D2, or D3.

Code	Description	
J2	ANSI/ASME B31.1	
J3	ANSI/ASME B31.3	
J4	ANSI/ASME B31.8	

Materials conformance

This option is not available with low power (output code M).

Materials of Construction comply with metallurgical requirements within NACE MR0175/ISO for sour oil field production environments. Environmental limits apply to certain materials. Consult latest standard for details. Selected materials also conform to NACE MR0103 for sour refining environments.

Code	Description	
J5	NACE MR-0175/ISO 15156	

Country certification

This option is not available with low power (output code M).

Code	Description	
J6	European Pressure Directive (PED)	★
J1	Canadian registration	

Transmitter calibration certification

This option is not available with low power (output code M).

Code	Description	
Q4	Calibration certificate for transmitter	★

Quality certification for safety

The quality certification for safety is only available with HART® 4–20 mA output (code A).

Code	Description	
QT	Safety certified to IEC 61508 with certificate of FMEDA	★

Product certifications

Code	Description	
E8	ATEX Flameproof and Dust Certification	★
I1 ⁽¹⁾	ATEX Intrinsic Safety and Dust	★
IA	ATEX FISCO Intrinsic Safety; for FOUNDATION™ Fieldbus or PROFIBUS® PA Protocol only	★
N1	ATEX Type n Certification and Dust	★
K8	ATEX Flameproof, Intrinsic Safety, Type n, Dust (combination of E8, I1 and N1)	★
E4	TIIS Flame-proof	★
I4	TIIS Intrinsic Safety	★
E5	USA Explosion-proof, Dust Ignition-Proof	★
I5 ⁽²⁾	USA Intrinsically Safe, Nonincendive	★
C6	Canada Explosion-proof, Dust Ignition-proof, Intrinsically Safe, and Division 2	★
E6	Canada Explosion-proof, Dust Ignition-proof, Division 2	★
I6	Canada Intrinsic Safety	★
K6	Canada and ATEX Explosion-proof, Intrinsically Safe, and Division 2 (combination of C6, E8, and I1)	★
E7	IECEX Flameproof, Dust Ignition-proof	★
I7	IECEX Intrinsic Safety	★
N7	IECEX Type n Certification	★
K7	IECEX Flame-proof, Dust Ignition-proof, Intrinsic Safety, and Type n (combination of I7, N7, and E7)	★
IG	IECEX FISCO Intrinsically Safe; for FOUNDATION Fieldbus or PROFIBUS PA Protocols only	★
K5	USA Explosion-proof, Dust Ignition-Proof, Intrinsically Safe, and Division 2	★
E2	INMETRO Flameproof001	★
I2	INMETRO Intrinsic Safety	★
IB	INMETRO FISCO intrinsically safe; for FOUNDATION Fieldbus or PROFIBUS PA Protocols only	★
K2	INMETRO Flameproof, Intrinsic Safety	★
E3	China Flameproof	★
I3	China Intrinsic Safety	★
N3	China Type n	★
EM	Technical Regulations Customs Union (EAC) Flameproof	★
IM	Technical Regulations Customs Union (EAC) Intrinsic Safety	★
KM	Technical Regulations Customs Union (EAC) Flameproof and Intrinsic Safety	★
KB	USA and Canada Explosion-proof, Dust Ignition Proof, Intrinsically Safe, and Division 2 (combination of K5 and C6)	★
KD	USA, Canada, and ATEX Explosion-proof, Intrinsically Safe (combination of K5, C6, I1, and E8)	★
KL ⁽³⁾	USA, Canada, IECEX, ATEX Intrinsic Safety Combination	★
KS	USA, Canada, IECEX, ATEX Explosion Proof, Intrinsically Safe, Dust, Non-Incendive, Type-N, Div. 2	★
EP	Republic of Korea Flameproof	★
IP	Republic of Korea Intrinsic Safety	★

KP	Republic of Korea Flameproof, Intrinsic Safety	★
----	--	---

- (1) *Dust approval not applicable to output code X.*
- (2) *Nonincendive certification not provided with output code (X).*
- (3) *Only available with output code X.*

Sensor fill fluid and O-ring options

This option is not available with low power (output code M).

Code	Description	
L1 ⁽¹⁾	Inert sensor fill fluid	★
L2	Graphite-filled (PTFE) O-ring	★
LA ⁽¹⁾	Inert sensor fill fluid and graphite-filled (PTFE) O-ring	★

- (1) *Not available with output code X.*

Display and interface options

This option is not available with low power (output code M).

Code	Description	
M4 ⁽¹⁾	LCD display with LOI	★
M5	LCD display	★

- (1) *Not available with FOUNDATION™ Fieldbus (output code F) or wireless (output code X).*

Transient protection

This option is not available with low power (output code M).

This option is not available with output code X.

This option is not available with housing code 00, 5A, or 7J. The T1 option is not needed with FISCO Product Certifications, transient protection is included with the FISCO Product Certification code IA.

Code	Description	
T1	Transient terminal block	★

Alarm limit

This option is not available with low power (output code M).

This option is only available with 4–20 mA HART® (output codes A and M).

Code	Description	
C4	NAMUR alarm and saturation levels, high alarm	★
CN	NAMUR alarm and saturation levels, low alarm	★
CR	Custom alarm and saturation signal levels, high alarm (requires C1 and Configuration Data Sheet)	★
CS	Custom alarm and saturation signal levels, low alarm (requires C1 and Configuration Data Sheet)	★
CT	Low alarm (standard Rosemount alarm and saturation levels)	★

Plantweb control functionality

This option is not available with low power (output code M).

This option is only valid with FOUNDATION™ Fieldbus (output code F).

Code	Description	
A01	FOUNDATION Fieldbus advanced control function block suite	★

Configuration buttons

This option is not available with low power (output code M).

Code	Description	
D4 ⁽¹⁾	Zero and span hardware adjustments	★
DZ ⁽²⁾	Digital zero trim	★

(1) Only available with 4–20 mA HART® (output codes A and M).

(2) Only available with 4–20 mA HART (output codes A and M) and wireless output (code X).

Ground screw

This option is not available with low power (output code M).

This option is not available with output code X.

The V5 option is not needed with the T1 option; external ground screw assembly is included with the T1 option.

Code	Description	
V5	External ground screw assembly	★

HART revision configuration

This option is not available with low power (output code M).

This option is only available with 4–20 mA HART® (output codes A and M).

Code	Description	
HR5 ⁽¹⁾	Configured for HART Revision 5	★
HR7 ⁽²⁾	Configured for HART Revision 7	★

(1) Configures the HART output to HART Revision 5. The device can be field configured to HART Revision 7 if needed.

(2) Configures the HART output to HART Revision 7. The device can be field configured to HART Revision 5 if needed.

Rosemount 2051L Liquid Level Transmitter



- Designed with a variety of process connections, materials and output protocols to meet diverse application requirements
- Tuned-System Level assembly and direct mounting produce optimal performance for level applications
- SIL 2/3 certified to IEC 61508 (via 3rd party) and prior-use certificate of FMEDA data for safety installations
- Local Operator Interface (LOI) for simple, local commissioning on-site without the use of extra tools or training
- Optimized seal system construction ensures a quality measurement in harsh process conditions

CONFIGURE >

VIEW PRODUCT >

Online product configurator

Many products are configurable online using our Product Configurator. Select the **Configure** button or visit our [website](#) to start. With this tool's built-in logic and continuous validation, you can configure your products more quickly and accurately.

Specifications and options

See the Specifications and options section for more details on each configuration. Specification and selection of product materials, options, or components must be made by the purchaser of the equipment. See the Material selection section for more information.

Model codes

Model codes contain the details related to each product. Exact model codes will vary; an example of a typical model code is shown in [Figure 7](#).

Figure 7: Model Code Example

3051C D 2 X 2 2 M5 B4
 1 2

1. Required model components (choices available on most)
2. Additional options (variety of features and functions that may be added to products)

Optimizing lead time

The starred offerings (★) represent the most common options and should be selected for best delivery. The non-starred offerings are subject to additional delivery lead time.

Required model components

Model

Code	Description	
2051L	Liquid level transmitter	★

Pressure range

Code	Description	
2	–250 to 250 inH ₂ O (–623 to 623 mbar)	★
3	–1000 to 1000 inH ₂ O (–2.5 to 2.5 bar)	★
4	–300 to 300 psi (–20.7 to 20.7 bar)	★

Transmitter output

Code	Description	
A ⁽¹⁾	4–20 mA with digital signal based on HART® Protocol	★
F	FOUNDATION™ Fieldbus Protocol	★
W ⁽²⁾	PROFIBUS® PA Protocol	★
X ⁽³⁾	Wireless	★
M ⁽⁴⁾	Low-power, 1–5 Vdc with digital signal based on HART Protocol	

(1) HART Revision 5 is the default HART output. The Rosemount 2051 with Selectable HART can be factory or field configured to HART Revision 7. To order HART Revision 7 factory configured, add option code HR7.

(2) For local addressing and configuration, M4 (LOI) is required. Not available with product certification codes E4, EM, EP, I6, IM, KD, KL, KM, KP, KS, N3

(3) Only available with intrinsically safe approvals.

(4) Only available with Housing Codes A and J and with C6, E2,E5, I5, K5, EM, EP, KB, and E8 product certifications.

Process connection size

Code	Description	Diaphragm	
G ⁽¹⁾	2-in./DN 50	316L SST	★
H ⁽¹⁾	2-in./DN 50	Alloy C-276	★
J	2-in./DN 50	Tantalum	★
A ⁽¹⁾	3-in./DN 80	316L SST	★
B ⁽¹⁾	4-in./DN 100	316L SST	★
C ⁽¹⁾	3-in./DN 80	Alloy C-276	★

Code	Description	Diaphragm	
D ⁽¹⁾	4-in./DN 100	Alloy C-276	★
E	3-in./DN 80	Tantalum	★
F	4-in./DN 100	Tantalum	★

(1) Materials of construction comply with metallurgical requirements highlighted within NACE MR0175/ISO 15156 for sour oil field production environments. Environmental limits apply to certain materials. Consult latest standard for details. Selected materials also conform to NACE[®]MR0103 for sour refining environments. Order with Q15 or Q25 to receive a NACE certificate.

Extension length

Code	Description	
0	None, flush mount	★
2	2-in./50 mm	★
4	4-in./100 mm	
6	6-in./150 mm	

Mounting flange size rating, material (high size)

Code	Description	Rating	Material	
M	2-in.	ASME B16.5 Class 150	CS	★
A	3-in.		CS	★
B	4-in.		CS	★
N	2-in.	ASME B16.5 Class 300	CS	★
C	3-in.		CS	★
D	4-in.		CS	★
X ⁽¹⁾	2-in.	ASME B16.5 Class 150	SST	★
F ⁽¹⁾	3-in.		SST	★
G ⁽¹⁾	4-in.		SST	★
Y ⁽¹⁾	Displayed	ASME B16.5 Class 300	SST	★
H ⁽¹⁾	3-in.		SST	★
J ⁽¹⁾	4-in.		SST	★
Q	DN 50	PN 10-40 per EN 1092-1	CS	★
R	DN 80	PN 40 per EN 1092-1	CS	★
K	DN 50	PN 10-40 per EN 1092-1	SST	★
T	DN 80	PN 40 per EN 1092-1	SST	★

(1) Materials of construction comply with metallurgical requirements highlighted within NACE MR0175/ISO 15156 for sour oil field production environments. Environmental limits apply to certain materials. Consult latest standard for details. Selected materials also conform to NACE[®]MR0103 for sour refining environments. Order with Q15 or Q25 to receive a NACE certificate.

Seal fill fluid (high side)

Code	Seal fill fluid (high side)	Specific gravity at 77 °F (25 °C)	Temperature limits (ambient temperature of 70 °F [21 °C])	
A	SYLTHERM™ XLT	0.085	-157 to 293 °F (-105 to 145 °C)	★
C	Silicone 704	1.07	32 to 401 °F (0 to 205 °C)	★
D	Silicone 200	0.93	-49 to 401 °F (-45 to 205 °C)	★
F	Silicone 200 for vacuum applications limits: For use in vacuum applications below 14.7 psia (1 bar-a), refer to vapor pressure curves in Rosemount DP Level Fill Fluid Specification Technical Note .			
H	Inert (halocarbon)	1.85	5 to 401 °F (-15 to 205 °C)	★
G	Glycerin and water	1.13	-49 to 320 °F (-45 to 160 °C)	★
L	Silicone 200 for vacuum applications limits: For use in vacuum applications below 14.7 psia (1 bar-a), refer to vapor pressure curves in Rosemount DP Level Fill Fluid Specification Technical Note .			
N	Neobee® M-20	0.92	5 to 401 °F (-15 to 205 °C)	★
P	Propylene glycol and water	1.02	5 to 203 °F (-15 to 95 °C)	★

Sensor module configuration, flange adapter (low side)

Code	Configuration	Flange adapter	
1	Gage	SST	★
2	Differential	SST	★
3 ⁽¹⁾	Tuned-System™ with remote seal	None	★

(1) Requires option code S1.

Sensor module diaphragm, sensor fill fluid (low side)

Code	Diaphragm material	Sensor fill fluid	
1	316L SST	Silicone	★
2	Alloy C-276 (SST valve seat)		★
7	Alloy C-276 (alloy C-276 valve seat)		★
A ⁽¹⁾	316L SST	Inert (halocarbon)	★
B ⁽¹⁾⁽²⁾	Alloy C-276 (SST valve seat)		★
G ⁽¹⁾	Alloy C-276 (alloy C-276 valve seat)		★

(1) Not available with output code X.

(2) Materials of construction comply with metallurgical requirements highlighted within NACE MR0175/ISO 15156 for sour oil field production environments. Environmental limits apply to certain materials. Consult latest standard for details. Selected materials also conform to NACE MR0103 for sour refining environments. Order with Q15 or Q25 to receive a NACE certificate.

O-ring

Code	Description	
A	Glass-filled PTFE	★

Housing material

Code	Description	Conduit entry size	
A	Aluminum	½–14 NPT	★
B	Aluminum	M20 x 1.5	★
E	Aluminum, ultra low copper	½–14 NPT	★
F	Aluminum, ultra low copper	M20 x 1.5	★
J	SST	½–14 NPT	★
K	SST	M20 x 1.5	★
P ⁽¹⁾	Engineered polymer	No conduit entries	★
D ⁽²⁾	Aluminum	G½	★
M ⁽²⁾	SST	G½	

(1) Only available with output code X.

(2) Transmitter conduit entry will be ½ NPT and a ½ NPT to G½ thread adapter will be provided. This option is only available with product certifications options I1, I2, I3, I7, IA, IB, IM, KA, N1, N3, N7. Housing code D is also available with E4, and IG.

Wireless options

Requires wireless output code X and engineered polymer housing code P.

Wireless transmit rate, operating frequency and protocol

Code	Description	
WA3	User configurable transmit rate, 2.4 GHz WirelessHART® Protocol	★

Antenna and SmartPower™

Code	Description	
WP5	Internal antenna, compatible with Green Power Module (I.S. Power Module sold separately)	★

Additional options

Extended product warranty

Code	Description	
WR3	3-year limited warranty	★
WR5	5-year limited warranty	★

Plantweb™ control functionality

This option is only valid with FOUNDATION™ Fieldbus output code F.

Code	Description	
A01	FOUNDATION Fieldbus advanced control function block suite	★

Seal assemblies

“Assemble-to” items are specified separately and require a completed model number.

Code	Description	
S1	Assemble to one Rosemount 1199 diaphragm seal	★

Remote seal diaphragm coating

Code	Description	
SZ	0.0002-in. (5 μm) gold-plated diaphragm	
FP ⁽¹⁾	CorrosionShield PFA coated diaphragm	
FG	PermeationShield™ 0.0002-in. (5μm) inner gold-plated diaphragm	

(1) Not compatible with spiral wound gasket.

Product certifications

Code	Description	
E8	ATEX Flameproof and Dust Certification	★
I1 ⁽¹⁾	ATEX Intrinsic Safety and Dust	★
IA	ATEX FISCO Intrinsic Safety; for FOUNDATION™ Fieldbus or PROFIBUS® PA Protocol only	★
N1	ATEX Type n Certification and Dust	★
K8	ATEX Flameproof, Intrinsic Safety, Type n, Dust (combination of E8, I1 and N1)	★
E4	TIIS Flame-proof	★
I4	TIIS Intrinsic Safety	★
E5	USA Explosion-proof, Dust Ignition-Proof	★
I5 ⁽²⁾	USA Intrinsically Safe, Nonincendive	★
C6	Canada Explosion-proof, Dust Ignition-proof, Intrinsically Safe, and Division 2	★
E6	Canada Explosion-proof, Dust Ignition-proof, Division 2	★
I6	Canada Intrinsic Safety	★
K6	Canada and ATEX Explosion-proof, Intrinsically Safe, and Division 2 (combination of C6, E8, and I1)	★
E7	IECEX Flameproof, Dust Ignition-proof	★
I7	IECEX Intrinsic Safety	★
N7	IECEX Type n Certification	★
K7	IECEX Flame-proof, Dust Ignition-proof, Intrinsic Safety, and Type n (combination of I7, N7, and E7)	★

IG	IECEX FISCO Intrinsically Safe; for FOUNDATION Fieldbus or PROFIBUS PA Protocols only	★
K5	USA Explosion-proof, Dust Ignition-Proof, Intrinsically Safe, and Division 2	★
E2	INMETRO Flameproof001	★
I2	INMETRO Intrinsic Safety	★
IB	INMETRO FISCO intrinsically safe; for FOUNDATION Fieldbus or PROFIBUS PA Protocols only	★
K2	INMETRO Flameproof, Intrinsic Safety	★
E3	China Flameproof	★
I3	China Intrinsic Safety	★
N3	China Type n	★
EM	Technical Regulations Customs Union (EAC) Flameproof	★
IM	Technical Regulations Customs Union (EAC) Intrinsic Safety	★
KM	Technical Regulations Customs Union (EAC) Flameproof and Intrinsic Safety	★
KB	USA and Canada Explosion-proof, Dust Ignition Proof, Intrinsically Safe, and Division 2 (combination of K5 and C6)	★
KD	USA, Canada, and ATEX Explosion-proof, Intrinsically Safe (combination of K5, C6, I1, and E8)	★
KL ⁽³⁾	USA, Canada, IECEX, ATEX Intrinsic Safety Combination	★
KS	USA, Canada, IECEX, ATEX Explosion Proof, Intrinsically Safe, Dust, Non-Incendive, Type-N, Div. 2	★
EP	Republic of Korea Flameproof	★
IP	Republic of Korea Intrinsic Safety	★
KP	Republic of Korea Flameproof, Intrinsic Safety	★

- (1) Dust approval not applicable to output code X.
- (2) Nonincendive certification not provided with output code (X).
- (3) Only available with output code X.

Shipboard approvals

Shipboard approvals are not available with wireless output (code X).

Code	Description	
SBS	American Bureau of Shipping	★
SBV	Bureau Veritas (BV)	★
SDN	Det Norske Veritas	★
SLL	Lloyds Register (LR)	★

SST tagging

Code	Description	
Y2	316SST Nameplate, top tag, wire-on tag, and fasteners	

Display and interface options

Code	Description	
M4 ⁽¹⁾	LCD display with LOI	★
M5	LCD display	★

(1) Not available with FOUNDATION™ Fieldbus (output code F) or wireless (output code X).

Flange adapters

This option is not valid with alternate process connection options S3, S4, S5, or S6.

Code	Description	
DF	½–14 NPT flange adapters	★

Conduit plug

Not available with output code X. Transmitter is shipped with 316 SST conduit plug (uninstalled) in place of standard CS conduit plug.

Code	Description	
DO	316 SST conduit plug	★

Ground screw

The V5 option is not needed with the T1 option; external ground screw assembly is included with the T1 option.

Code	Description	
V5	External ground screw assembly	★

Transient protection

Not available with output code X. Not valid with FOUNDATION™ Fieldbus output code F and wireless output code X. The T1 option is not needed with FISCO Product Certifications; transient protection is included in the FISCO product certification codes IA, E, IF, and IG.

Code	Description	
T1	Transient terminal block	★

Software configuration

Only available with 4–20 mA HART output (codes A) and wireless output (code X).

Code	Description	
C1	Custom software configuration (requires completed Configuration Data Sheet)	★

Alarm limit

Only available with 4–20 mA HART (output codes A and M).

Code	Description	
C4 ⁽¹⁾	NAMUR alarm and saturation levels, high alarm	★

Code	Description	
CN ⁽¹⁾	NAMUR alarm and saturation levels, low alarm	★
CR	Custom alarm and saturation signal levels, high alarm (requires C1 and Configuration Data Sheet)	★
CS	Custom alarm and saturation signal levels, low alarm (requires C1 and Configuration Data Sheet)	★
CT	Low alarm (standard Rosemount alarm and saturation levels)	★

(1) NAMUR-Compliant operation is pre-set at the factory.

Calibration certification

Code	Description	
Q4	Calibration certificate	★

Material traceability certification

Code	Description	
Q8	Material traceability certification per EN 10204 3.1	★

Quality certification for safety

The option is only available with 4–20 mA HART[®] output (code A).

Code	Description	
QT	Safety certified to IEC 61508 with certificate of FMEDA	★

Toolkit total system performance reports

Code	Description	
QZ	Remote seal system performance calculation report	★

Conduit electrical connector

This option is not available with output code X.

Code	Description	
GE	M12, 4-pin, male connector (eurofast [®])	★
GM	A size mini, 4-pin, male connector (minifast [®])	★

NACE[®] certificate

NACE Compliant wetted materials are identified by materials of construction that comply with recommendations per NACE MR0175/ISO 15156 for sour oil field production environments. Environmental limits apply to certain materials. Consult latest standard for details. Selected materials also conform to NACE MR0103 for sour refining).

Code	Description	
Q15	Certificate of compliance to NACE MR0175/ISO 15156 for wetted materials	★
Q25	Certificate of compliance to NACE MR0103 for wetted materials	★

Positive material identification (PMI)

Code	Description	
Q76	PMI verification and certificate	★

Lower housing alignment clamp

Code	Description	
SA	Lower housing alignment clamp	★

Lower housing flushing connection

Code	Ring material	Number	Size (NPT)	
F1	316 SST	1	¼–18 NPT	★
F2	316 SST	2	¼–18 NPT	★
F3 ⁽¹⁾	Alloy C-276	1	¼–18 NPT	★
F4 ⁽¹⁾	Alloy C-276	2	¼–18 NPT	★
F7	316 SST	1	½–14 NPT	★
F8	316 SST	2	½–14 NPT	★
F9	Alloy C-276	1	½–14 NPT	★
F10	Alloy C-276	2	½–14 NPT	★

(1) Not available with option codes A0, B0, and G0.

HART revision configuration

Only available with 4–20 mA HART® (output code A).

Code	Description	
HR5 ⁽¹⁾	Configured for HART Revision 5	★
HR7 ⁽²⁾	Configured for HART Revision 7	★

(1) Configures the HART output to HART Revision 5. The device can be field configured to HART Revision 7 if needed.

(2) Configures the HART output to HART Revision 7. The device can be field configured to HART Revision 5 if needed.

Wireless power accessory

This option is only available with output code X.

Code	Description	
HS	Hot swap power adapter for power module replacement	

Specifications

Performance specifications

This product data sheet covers HART®, Wireless, FOUNDATION™ Fieldbus, and PROFIBUS® PA Protocols unless specified.

Conformance to specification ($\pm 3\sigma$ [sigma])

Technology leadership, advanced manufacturing techniques, and statistical process control ensure specification conformance to at least $\pm 3\sigma$.

Reference accuracy

Stated reference accuracy equations include terminal based linearity, hysteresis, and repeatability. For Wireless, FOUNDATION™ Fieldbus, and PROFIBUS® PA devices, use calibrated range in place of span.

Models	Standard	High performance option, P8	
Rosemount 2051C3			
Range 1	±0.10 percent of span For spans less than 15:1, accuracy = $\pm\left(0.025 + 0.005\left[\frac{URL}{Span}\right]\right)\%$ of span	N/A	N/A
Ranges 2–4	±0.065 percent of span For spans less than 10:1, accuracy = $\pm\left(0.025 + 0.005\left[\frac{URL}{Span}\right]\right)\%$ of span	Ranges 2–4	High accuracy option, P8 ±0.05 percent of span For spans less than 10:1 ⁽¹⁾ , accuracy = $\pm\left(0.015 + 0.005\left[\frac{URL}{Span}\right]\right)\%$ of span
Range 5	±0.075 percent of span For spans less than 10:1, accuracy= $\pm\left(0.025 + 0.005\left[\frac{URL}{Span}\right]\right)\%$ of span	Range 5	High performance option, P8 ±0.065 percent of span For spans less than 10:1, accuracy= $\pm\left(0.015 + 0.005\left[\frac{URL}{Span}\right]\right)\%$ of span
Rosemount 2051T, 2051G⁽²⁾			
Ranges 0	±0.065 percent of span For spans from 5:1 to 20:1, accuracy = $\pm\left(0.06 + 0.012\left[\frac{URL}{Span}\right]\right)\%$ of span	N/A	N/A
Ranges 1–4	±0.065 percent of span For spans less than 10:1, accuracy = $\pm\left(0.0075\left[\frac{URL}{Span}\right]\right)\%$ of span	Ranges 1–4	High accuracy option, P8 ±0.05 percent of span For spans less than 10:1 ⁽¹⁾ , accuracy = $\pm\left(0.0075\left[\frac{URL}{Span}\right]\right)\%$ of span
Range 5 ⁽³⁾	±0.075 percent of span	N/A	N/A

Models	Standard	High performance option, P8	
Rosemount 2051L			
Ranges 2–4	±0.075 percent of span For spans less than 10:1, accuracy = $\pm\left(0.025 + 0.005\left[\frac{URL}{Span}\right]\right)\%$ of span	N/A	N/A

(1) For protocol code F, accuracy specification is for spans less than 7:1. Not available with output code W.

(2) For Rosemount 2051C, 2051T, and 2051G with 1199 assemble to code S1, use 3051L specification.

(3) Rosemount 2051G is not available with range 5.

Flow performance

Flow reference accuracy

Rosemount 2051CFA Annubar Flow Meter		
Ranges 2–3		±2.00 percent of flow rate at 5:1 flow turndown
Rosemount 2051CFC_A Compact Annubar Flow Meter — Annubar option A		
Ranges 2–3	Standard	±2.60 percent of flow rate at 5:1 flow turndown
	Calibrated	±2.30 percent of flow rate at 5:1 flow turndown
Rosemount 2051CFC Compact Orifice Flow Meter — conditioning option C		
Ranges 2–3	β = 0.4	±2.25 percent of flow rate at 5:1 flow turndown
	β = 0.65	±2.45 percent of flow rate at 5:1 flow turndown
Rosemount 2051CFC Compact Orifice Flow Meter — Orifice Type Option P⁽¹⁾		
Ranges 2–3	β = 0.4	±2.50 percent of flow rate at 5:1 flow turndown
	β = 0.65	±2.50 percent of flow rate at 5:1 flow turndown
Rosemount 2051CFP Integral Orifice Flow Meter		
Ranges 2–3	Bore < 0.1	±3.10 percent of flow rate at 5:1 flow turndown
	0.1 < bore < 0.2	±2.75 percent of flow rate at 5:1 flow turndown
	0.2 < bore < 0.6	±2.25 percent of flow rate at 5:1 flow turndown
	0.6 < bore < 0.8	±3.00 percent of flow rate at 5:1 flow turndown

(1) For smaller line sizes, see Rosemount Compact Orifice.

Long-term stability

±50 °F (28 °C) temperature changes and up to 1000 psi. (6,9 MPa) line pressure.

Models	Standard	High performance option, P8
Rosemount 2051C		
Range 1 (CD)	±0.2 percent of URL for 1 year	±0.175 percent of URL for 7 years
Ranges 2–5	±0.125 percent of URL for 5 years	
Rosemount 2051T, 2051G		
Ranges 1–5 ⁽¹⁾	±0.125 percent of URL for 5 years	±0.15 percent of URL for 7 years

(1) Rosemount 2051G is not available with range 5.

Dynamic performance

	4–20 mA HART ⁽¹⁾ 1–5 Vdc HART Low Power	FOUNDATION Fieldbus and PROFIBUS PA Protocols ⁽²⁾	Typical HART Transmitter Response Time
Total response time ($T_d + T_c$):			<p>Transmitter Output vs. Time</p> <p>Pressure released</p> <p>100%</p> <p>36.8%</p> <p>0%</p> <p>Time</p> <p>T_d = Dead time T_c = Time constant Response time = $T_d + T_c$</p> <p>63.2% of total step change</p>
Rosemount 2051C Range 3–5:	115 ms	152 ms	
Range 1: Range 2: 2051T and 2051G: 2051L:	270 ms 130 ms 100 ms See Instrument Toolkit™	307 ms 152 ms 152 ms See Instrument Toolkit	
Dead time (T_d)	60 ms (nominal ⁽³⁾)	97 ms	
Update rate ⁽⁴⁾	22 times per second		

- (1) Dead time and update rate apply to all models and ranges; analog output only.
- (2) Transducer block response time, analog input block execution time not included.
- (3) Nominal total response time at 75 °F (24 °C) reference conditions.
- (4) Does not apply to wireless (output code X). See [Wireless \(output code X\)](#) for wireless update rate.

Line pressure effect per 1000 psi (6,9 MPa)

For line pressures above 2000 psi (13,7 MPa) and ranges 4–5, see Rosemount 2051 Reference Manual for HART®, Rosemount 2051 Reference Manual for WirelessHART®, Rosemount 2051 Reference Manual for FOUNDATION™ Fieldbus, and Rosemount 2051 Reference Manual PROFIBUS® PA.

Models	Line pressure effect	
Rosemount 2051CD, 2051CF	Zero Error ⁽¹⁾	Span error
Range 1	±0.25 percent of URL/1000 psi (68,9 bar)	±0.4 percent of reading/1,000 psi (68,9 bar)
Ranges 2–3	±0.05 percent of URL/1000 psi (68,9 bar) for line pressures from 0 to 2000 psi (0 to 13,7 MPa)	±0.1 percent of reading/1,000 psi (68,9 bar)

- (1) Can be calibrated out at line pressure.

Ambient temperature effect per 50 °F (28 °C)

Models	Ambient temperature effect
Rosemount 2051C, 2051CF	
Ranges 2–5	±(0.025% URL + 0.125% span) from 1:1 to 5:1 ±(0.05% URL + 0.25% span) from 5:1 to 100:1
Range 1	±(0.1% URL + 0.25% span) from 1:1 to 30:1
Rosemount 2051T, 2051G	
Range 0	± (0.3% URL + 0.15% span) from 1:1 to 20:1
Range 2–4	±(0.05% URL + 0.25% span) from 1:1 to 30:1 ±(0.07% URL + 0.25% span) from 30:1 to 100:1
Range 1	±(0.05% URL + 0.25% span) from 1:1 to 10:1 ±(0.10% URL + 0.25% span) from 10:1 to 100:1
Range 5 ⁽¹⁾	±(0.1% URL + 0.15% span) from 1:1 to 5:1
Rosemount 2051L	See Instrument Toolkit™

- (1) Rosemount 2051G is not available with range 5.

Mounting position effects

Models	Mounting position effects
Rosemount 2051C	Zero shifts up to ± 1.25 inH ₂ O (3,1 mbar), which can be calibrated out. No span effect.
Rosemount 2051T and 2051G	Zero shifts up to ± 2.5 inH ₂ O (6,2 mbar), which can be calibrated out. No span effect.
Rosemount 2051L	With liquid level diaphragm in vertical plane, zero shift of up to 1 inH ₂ O (2,49 mbar). With diaphragm in horizontal plane, zero shift of up to 5 inH ₂ O (12,43 mbar) plus extension length on extended units. Zero shifts can be calibrated out. No span effect.

Vibration effect

Less than ± 0.1 percent of URL when tested per the requirements of IEC60770-1 field or pipeline with high vibration level (10–60 Hz 0.21 mm displacement peak amplitude/60–2000 Hz 3g).

Power supply effect

Less than ± 0.005 percent of calibrated span per volt.

Electromagnetic compatibility

Meets all industrial environment requirements of EN61326 and NAMUR NE-21. Maximum deviation <1 percent Span during EMC disturbance.

Note

NAMUR NE-21 does not apply to Low-Power (Transmitter output option code M) or Wireless (Transmitter output code X).

Note

During surge event, device with 4-20mA (Transmitter output option code A) may exceed maximum EMC deviation limit or reset; however, device will self-recover and return to normal operation within specified start-up time.

Transient protection (option code T1)

Meets IEEE C62.41, category location B

- 6 kV crest (0.5 μ s–100 kHz)
- 3 kA crest (8 x 20 microseconds)
- 6 kV crest (1.2 x 50 microseconds)

Functional specifications**Range and sensor limits**

Table 1: Rosemount 2051CD, 2051CF, 2051CG, and 2051L

Range	Minimum span	Upper (URL)	Lower (LRL)			
			Rosemount 2051C Differential, 2051CF Flow Meters	Rosemount 2051C Gage ⁽¹⁾	Rosemount 2051L Differential	Rosemount 2051L Gage ⁽¹⁾
1	0.5 inH ₂ O (1,2 mbar)	25 inH ₂ O (62,3 mbar)	-25 inH ₂ O (-62,1 mbar)	-25 inH ₂ O (-62,1 mbar)	N/A	N/A
2	2.5 inH ₂ O (6,2 mbar)	250 inH ₂ O (0,62 bar)	-250 inH ₂ O (-0,62 bar)	-250 inH ₂ O (-0,62 bar)	-250 inH ₂ O (-0,62 bar)	-250 inH ₂ O (-0,62 bar)

Table 1: Rosemount 2051CD, 2051CF, 2051CG, and 2051L (continued)

Range	Minimum span	Upper (URL)	Lower (LRL)			
			Rosemount 2051C Differential, 2051CF Flow Meters	Rosemount 2051C Gage ⁽¹⁾	Rosemount 2051L Differential	Rosemount 2051L Gage ⁽¹⁾
3	10 inH ₂ O (24,9 mbar)	1000 inH ₂ O (2,49 bar)	-1000 inH ₂ O (-2,49 bar)	-393 inH ₂ O (-979 mbar)	-1000 inH ₂ O (-2,49 bar)	-393 inH ₂ O (-979 mbar)
4	3 psi (0,207 bar)	300 psi (20,7 bar)	-300 psi (-20,7 bar)	-14.2 psig (-979 mbar)	-300 psi (-20,7 bar)	-14.2 psig (-979 mbar)
5	20 psi (1,38 bar)	2000 psi (137,9 bar)	-2000 psi (-137,9 bar)		N/A	N/A

(1) Assumes atmospheric pressure of 14.7 psig.

Table 2: Rosemount 2051T and 2051G

Range	Minimum span	Upper (URL)	Lower (LRL) - Absolute	Lower ⁽¹⁾ (LRL) - Gage
0	0.25 psi (17.24 mbar)	5 psi (344.74 mbar)	N/A	-5 psi (-344.74 mbar)
1	0.3 psi (20,7 mbar)	30 psi (2,07 bar)	0 psia (0 bar)	-14.7 psig (-1,01 bar)
2	1.5 psi (0,103 bar)	150 psi (10,3 bar)		
3	8 psi (0,55 bar)	800 psi (55,2 bar)		
4	40 psi (2,76 bar)	4000 psi (275,8 bar)		
5 ⁽²⁾	2000 psi (137,9 bar)	10,000 psi (689,5 bar)		

(1) Assumes atmospheric pressure of 14.7 psig.

(2) Rosemount 2051G is not available with range 0 or range 5.

Service

Liquid, gas, and vapor applications

Protocols

4–20 mA HART® (output code A)

Power supply

External power supply required. Standard transmitter operates on 10.5–42.4 Vdc with no load.

Load limitations

Maximum loop resistance is determined by the voltage level of the external power supply described by:

Max. loop resistance = 43.5 (power supply voltage - 10.5)

Communication requires a minimum loop resistance of 250 ohms.

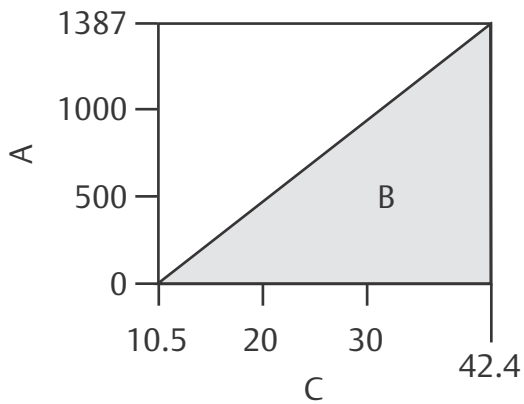

- A. Load (Ω s)
- B. Operating region
- C. Voltage (Vdc)

Note

For CSA approval, power supply must not exceed 42.4 V.

Indication

Optional two line LOI/LCD display

Zero and span adjustment requirements

Zero and span values can be set anywhere within the range limits stated in [Table 1](#) and [Table 2](#).

Span must be greater than or equal to the minimum span stated in [Table 1](#) and [Table 2](#).

Output

Two-wire 4–20 mA, user selectable for linear or square root output. Digital process variable superimposed on 4–20 mA signal, available to any host that conforms to HART Protocol.

Rosemount 2051 with Selectable HART

The Rosemount 2051 with Selectable HART comes with Selectable HART Revisions. Digital communications based on HART Revision 5 (default) or Revision 7 (option code HR7) Protocol can be selected. The HART revision can be switched in the field using any HART based configuration tool or the optional LOI.

LOI

The LOI utilizes a two-button menu with internal and external configuration buttons. Internal buttons are always configured for LOI. External buttons can be configured for either LOI, (option code M4), analog zero and span (option code D4) or digital zero trim (option code DZ). See [Rosemount 2051 with Selectable HART Reference Manual](#) for LOI configuration menu.

FOUNDATION™ Fieldbus (output code F)

Power supply

External power supply required; transmitters operate on 9.0–32.0 Vdc transmitter terminal voltage for non-I.S. applications, 9.0–30 Vdc for entity model intrinsically safe applications and 9.0–17.5 Vdc for FISCO intrinsically safe applications.

Current draw

17.5 mA for all configurations (including LCD display option)

Indication

Optional two-line LCD display

FOUNDATION Fieldbus Function block Execution times

Block	Execution time
Resource	N/A
Transducer	N/A
LCD display block	N/A
Analog input 1, 2	20 milliseconds
PID	25 milliseconds
Arithmetic	20 milliseconds
Input selection	20 milliseconds
Signal characterizer	20 milliseconds
Integrator	20 milliseconds
Output splitter	20 milliseconds
Control selector	20 milliseconds

FOUNDATION Fieldbus parameters

Schedule entries	Links	Virtual communications relationships (VCR)
7 (max.)	25 (max.)	20 (max.)

Standard function blocks

Analog input (AI) block

The AI function block processes the measurements from the sensor and makes them available to other function blocks. The output value from the AI block is in engineering units and contains a status indicating the quality of the measurement. The AI block is widely used for scaling functionality.

Note

The channel, Set XD_Scale, Set L_Type, and sometimes Set Out_Scale are typically configured by instrument personnel. Other AI block parameters, block links, and schedule are typically configured by the control systems configuration engineer.

Backup link active scheduler (LAS)

The transmitter can function as a LAS if the current link master device fails or is removed from the segment.

PROFIBUS® PA (output code W)

Profile version

3.02

Power supply

External power supply required; transmitters operate on 9.0–32.0 Vdc transmitter terminal voltage for non-I.S. applications, 9.0–30 Vdc for entity model intrinsically safe applications and 9.0–17.5 Vdc for FISCO intrinsically safe applications.

Current draw

17.5 mA for all configurations (including LCD display option)

Output update rate

Four times per second

Standard function blocks

Analog input (AI) block

The AI function block processes the measurements from the sensor and makes them available to other function blocks. The output value from the AI block is in engineering units and contains a status indicating the quality of the measurement. The AI block is widely used for scaling functionality.

Note

The channel, Set XD_Scale, Set L_Type, and sometimes Set Out_Scale are typically configured by instrument personnel. Other AI block parameters, block links, and schedule are typically configured by the control systems configuration engineer.

Indication

Optional two-line LCD display

LOI

Optional external configuration buttons

Wireless (output code X)

Output

IEC 62591 (*WirelessHART*), 2.4 GHz DSSS

Wireless radio (internal antenna, WP5 option)

- Frequency: 2.400–2.485 GHz
- Channels: 15
- Modulation: IEEE 802.15.4 compliant DSSS
- Transmission: Maximum of 10 dBm EIRP

Local display

The optional three-line, seven-digit LCD display can display user-selectable information such as primary variable in engineering units, scaled variable, percent of range, sensor module temperature, and electronics temperature. The display updates based on the wireless update rate.

Digital zero trim

Digital zero trim (option DZ) is an offset adjustment to compensate for mounting position effects, up to 5 percent of URL.

Update rate

User selectable 1 second to 60 minutes

Wireless sensor module for in-line transmitters

The Rosemount 2051 Wireless Transmitter requires the engineered polymer housing to be selected. The standard sensor module will come with aluminum material. If SST is required, the option WSM must be selected.

Power module

Field replaceable, keyed connection eliminates the risk of incorrect installation, Intrinsically Safe Lithium-thionyl chloride Power Module with PBT/PC enclosure. 10-year life at one minute update rate.

Note

Reference conditions are 70 °F (21 °C), and routing data for three additional network devices. Continuous exposure to ambient temperature limits of -40 to 185 °F (-40 to 85 °C) may reduce specified life by less than 20 percent.

HART 1–5 Vdc low power (output code M)

Output

Three-wire 1–5 Vdc output, user-selectable for linear or square root output. Digital process variable superimposed on voltage signal, available to any host conforming to the HART Protocol.

Power consumption

3.0 mA, 27–84 mW

Output load

100 kΩ or greater (meter input impedance)

Turn-on time

Performance within specifications less than two seconds after power is applied to the transmitter.

Overpressure limits

Transmitters withstand the following limits without damage:

Rosemount 2051C, 2051CF

- Ranges 2–5: 3,626 psig (250 bar) 4,500 psig (310,3 bar) for option code P9
- Range 1: 2,000 psig (137,9 bar)

Rosemount 2051T, 2051G

- Range 0: 60 psi (4.14 bar)
- Range 1: 750 psi (51,7 bar)
- Range 2: 1,500 psi (103,4 bar)
- Range 3: 1,600 psi (110,3 bar)

- Range 4: 6,000 psi (413,7 bar)
- Range 5: 15,000 psi (1034,2 bar)⁽¹⁾

Rosemount 2051L

Limit is flange rating or sensor rating, whichever is lower (See [Table 3](#)).

Table 3: Rosemount 2051L Flange Rating

Standard	Type	CS rating	SST rating
ANSI/ASME	Class 150	285 psig	275 psig
ANSI/ASME	Class 300	740 psig	720 psig
At 100 °F (38 °C), the rating decreases with increasing temperature, per ANSI/ASME B16.5.			
DIN	PN 10–40	40 bar	40 bar
DIN	PN 10/16	16 bar	16 bar
At 248 °F (120 °C), the rating decreases with increasing temperature, per DIN 2401.			

Static pressure limit

Rosemount 2051CD, 2051CF

- Operates within specifications between static line pressures of –14.2 and 3626 psig (0,034 and 250 bar)
- For option code P9, 4500 psig (310,3 bar)
- Range 1: 0.5 psia to 2000 psig (34 mbar and 137,9 bar)

Burst pressure limits

Rosemount 2051C, 2051CF coplanar or traditional transmitter flange

10,000 psig (689.5 bar)

Rosemount 2051T in-line

- Ranges 0–4: 11000 psi (758,4 bar)
- Range 5: 26000 psi (1792,6 bar)

Temperature limits

Ambient

–40 to 185 °F (–40 to 85 °C)

with LCD display: –40 to 175 °F (–40 to 80 °C)

Note

Rosemount 2051 LCD display may not be readable and LCD display updates may be slower at temperatures below –22 °F (–30 °C).

Note

Wireless LCD display may not be readable and LCD display updates will be slower at temperatures below –4 °F (–20 °C).

Storage

–50 to 230 °F (–46 to 110 °C)

(1) The Rosemount 2051G is not available with range 5.

with LCD display: -40 to 185 °F (-40 to 85 °C)

with Wireless output: -40 to 185 °F (-40 to 85 °C)

Process

At atmospheric pressures and above. See [Table 4](#).

Table 4: Process Temperature Limits

Rosemount 2051C, 2051CF	
Silicone fill sensor⁽¹⁾	
with coplanar flange	-40 to 250 °F (-40 to 121 °C) ⁽²⁾
with traditional flange	-40 to 300 °F (-40 to 149 °C) ⁽²⁾⁽³⁾
with level flange	-40 to 300 °F (-40 to 149 °C) ⁽²⁾
with Rosemount 305 Integral Manifold	-40 to 300 °F (-40 to 149 °C) ⁽²⁾
Inert fill sensor ⁽¹⁾	-40 to 185 °F (-40 to 85 °C) ⁽³⁾
Rosemount 2051T (process fill fluid)	
Silicone fill sensor ⁽¹⁾	-40 to 250 °F (-40 to 121 °C) ⁽²⁾
Inert fill sensor ⁽¹⁾	-22 to 250 °F (-30 to 121 °C) ⁽²⁾
Rosemount 2051L low side temperature limits	
Silicone fill sensor ⁽¹⁾	-40 to 250 °F (-40 to 121 °C) ⁽²⁾
Inert fill sensor ⁽¹⁾	-40 to 185 °F (-40 to 85 °C) ⁽²⁾
Rosemount 2051L high side temperature limits (process fill fluid)	
SYLTHERM™ XLT	-102 to 293 °F (-75 to 145 °C)
Silicone 704	32 to 401 °F (0 to 205 °C)
Silicone 200	-49 to 401 °F (-45 to 205 °C)
Inert	-49 to 320 °F (-45 to 160 °C)
Glycerin and water	5 to 203 °F (-15 to 95 °C)
Neobee® M-20	5 to 401 °F (-15 to 205 °C)
Propylene glycol and water	5 to 203 °F (-15 to 95 °C)

(1) Process temperatures above 185 °F (85 °C) require derating the ambient limits by a 1.5:1 ratio.

(2) 220 °F (104 °C) limit in vacuum service; 130 °F (54 °C) for pressures below 0.5 psia.

(3) 160 °F (71 °C) limit in vacuum service.

Humidity limits

0–100 percent relative humidity

Volumetric displacement

Less than 0.005 in³ (0,08 cm³)

Damping

4–20 mA HART[®] Protocol

Analog output response to a step input change is user-enterable from 0–60 seconds for one time constant. This software damping is in addition to sensor module response time.

FOUNDATION[™] Fieldbus Protocol

Transducer block: User configurable

AI block: User configurable

PROFIBUS[®] PA Protocol

AI block only: User configurable

Failure mode alarm

4–20 mA HART Protocol (output code A)

If self-diagnostics detect a sensor or microprocessor failure, the analog signal is driven either high or low to alert the user. High or low failure mode is user-selectable with a jumper on the transmitter. The values to which the transmitter drives its output in failure mode depend on whether it is factory-configured to standard or NAMUR-compliant operation. The values for each are as follows:

Table 5: Standard Operation

Output code	Linear output	Fail high	Fail low
A	$3.9 \leq I \leq 20.8$	$I \geq 21.75 \text{ mA}$	$I \leq 3.75 \text{ mA}$
M	$0.97 \leq V \leq 5.2$	$V \geq 5.4 \text{ V}$	$V \leq 0.95 \text{ V}$

Table 6: NAMUR-Compliant Operation

Output code	Linear output	Fail high	Fail low
A	$3.8 \leq I \leq 20.5$	$I \geq 22.5 \text{ mA}$	$I \leq 3.6 \text{ mA}$

Output code F and X

If self-diagnostics detect a gross transmitter failure, that information gets passed as a status along with the process variable.

Physical specifications

Material selection

Emerson provides a variety of Rosemount product with various product options and configurations including materials of construction that can be expected to perform well in a wide range of applications. The Rosemount product information presented is intended as a guide for the purchaser to make an appropriate selection for the application. It is the purchaser's sole responsibility to make a careful analysis of all process parameters (such as all chemical components, temperature, pressure, flow rate, abrasives, contaminants, etc.), when specifying product, materials, options, and components for the particular application. Emerson is not in

a position to evaluate or guarantee the compatibility of the process fluid or other process parameters with the product, options, configuration or materials of construction selected.

Electrical connections

½–14 NPT, G½, and M20 x 1.5 conduit

Process connections

Rosemount 2051C

- ¼–18 NPT on 2½-in. centers
- ½–14 NPT and RC½ on 2-in. (50,8 mm), 2⅝-in. (54,0 mm), or 2¼-in. (57,2 mm) centers (process adapters)

Rosemount 2051T, 2051G

- ½–14 NPT female
- G½ A DIN 16288 male (available in SST for range 1–4 transmitters only)
- Autoclave type F-250-C (pressure relieved 9/16–18 gland thread; ¼ O.D. high pressure tube 60° cone; available in SST for range 5 transmitters only)

Rosemount 2051L

- High pressure side: 2-in. (50,8 mm), 3-in. (72 mm), or 4-in. (102 mm), ASME B 16.5 (ANSI) Class 150 or 300 flange; 50, 80, or 100 mm, DIN 2501 PN 40 or 10/16 flange
- Low pressure side: ¼–18 NPT on flange, ½–14 NPT on process adapter

Rosemount 2051CF

- For Rosemount 2051CFA wetted parts, see Rosemount DP Flow Meters and Primary Elements [Product Data Sheet](#) in the 485 section
- For Rosemount 2051CFC wetted parts, see Rosemount DP Flow Meters and Primary Elements [Product Data Sheet](#) in the 405 section
- For Rosemount 2051CFP wetted parts, see Rosemount DP Flow Meters and Primary Elements [Product Data Sheet](#) in the 1195 section

Rosemount 2051C process wetted parts

Drain/vent valves

316 SST or alloy C-276

Transmitter flanges and adapters

Plated CS, SST CF-8M (cast version of 316 SST, material per ASTM-A743), or CW2M (cast version of alloy C)

Wetted O-rings

Glass-filled PTFE or graphite-filled PTFE

Process isolating diaphragms

316L SST, alloy C-276, or tantalum

Rosemount 2051T process wetted parts

Process connections

316L SST or alloy C-276

Process Isolating diaphragms

316L SST or alloy C-276

Rosemount 2051L process wetted parts**Flanged process connection (transmitter high side)**

Process diaphragms, including process gasket surface	316L SST, alloy C-276, or Tantalum
Extension	CF-3M (cast version of 316L SST, material per ASTM-A743), or cast C-276. Fits schedule 40 and 80 pipe.
Mounting flange	Zinc-cobalt plated CS or SST

Reference process connection (transmitter low side)

Isolating diaphragms	316L SST or alloy C-276
Reference flange and adapter	CF-8M (cast version of 316 SST, material per ASTM-A743)

Non-wetted parts for Rosemount 2051C, 2051T, 2051L, 2051G**Electronics housing**

Low-copper aluminum or CF-8M (cast version of 316 SST) Enclosures meet NEMA Type 4X, IP66, and IP68 when properly installed. Housing material code P: PBT/PC with NEMA 4X and IP66/67/68

Paint for aluminum housing

Polyurethane

Coplanar sensor module housing

CF-3M (cast version of 316L SST)

Bolts

ASTM A449, Type 1 (zinc-cobalt plated CS) ASTM F593G, Condition CW1 (austenitic 316 SST) ASTM A193, Grade B7M (zinc plated alloy steel) Alloy K-500

Sensor module fill fluid

Silicone or inert halocarbon

In-line series uses Fluorinert® FC-43

Process fill fluid (Rosemount 2051L only)

Syltherm XLT, Silicone 704, Silicone 200, inert, glycerin and water, Neobee® M-20, or propylene glycol and water

Cover O-rings

Buna-N

Silicone (for wireless option code X)

Power module

Field replaceable, keyed connection eliminates the risk of incorrect installation, Intrinsically Safe Lithium-thionyl chloride power module with PBT enclosure.

Shipping weights

Table 7: Transmitter Weights without Options

Transmitter weights include the sensor module and housing only (aluminum for standard Rosemount 2051 and polymer for wireless).

Transmitter	Standard in lb. (kg)	Wireless in lb. (kg)
Rosemount 2051C	4.9 (2.2)	3.9 (1,8)
Rosemount 2051L	See Table 8	See Table 8
Rosemount 2051T	3.1 (1.4)	1.9 (0,86)
Rosemount 2051G	2.4 (1,1)	N/A

Table 8: Rosemount 2051L Weights without Options

Flange	Flush in lb. (kg)	2-in. ext. in lb. (kg)	4-in. ext. in lb. (kg)	6-in. ext. in lb. (kg)
2-in., Class 150	12.5 (5,7)	N/A	N/A	N/A
3-in., Class 150	17.5 (7,9)	19.5 (8,8)	20.5 (9,3)	21.5 (9,7)
4-in., Class 150	23.5 (10,7)	26.5 (12,0)	28.5 (12,9)	30.5 (13,8)
2-in., Class 300	17.5 (7,9)	N/A	N/A	N/A
3-in., Class 300	22.5 (10,2)	24.5 (11,1)	25.5 (11,6)	26.5 (12,0)
4-in., Class 300	32.5 (14,7)	35.5 (16,1)	37.5 (17,0)	39.5 (17,9)
DN 50/PN 40	13.8 (6,2)	N/A	N/A	N/A
DN 80/PN 40	19.5 (8,8)	21.5 (9,7)	22.5 (10,2)	23.5 (10,6)
DN 100/PN 10/16	17.8 (8,1)	19.8 (9,0)	20.8 (9,5)	21.8 (9,9)
DN 100/PN 40	23.2 (10,5)	25.2 (11,5)	26.2 (11,9)	27.2 (12,3)

Table 9: Transmitter Option Weights

Code	Option	Add lb. (kg)
J, K, L, M	SST housing	3.9 (1,8)
M5	LCD display for aluminum housing	0.5 (0,2)
M5	LCD display for wireless output	0.1 (0,04)
B4	SST mounting bracket for coplanar flange	1.0 (0,5)
B1, B2, B3	Mounting bracket for traditional flange	2.3 (1,0)
B7, B8, B9	Mounting bracket for traditional flange	2.3 (1,0)
BA, BC	SST bracket for traditional flange	2.3 (1,0)
H2	Traditional flange	2.6 (1,2)
H3	Traditional flange	3.0 (1,4)
H4	Traditional flange	3.0 (1,4)
H7	Traditional flange	2.7 (1,2)
FC	Level flange—3-in., Class 150	12.7 (5,8)
FD	Level flange—3-in., Class 300	15.9 (7,2)

Table 9: Transmitter Option Weights (continued)

Code	Option	Add lb. (kg)
FA	Level flange—2-in., Class 150	8.0 (3,6)
FB	Level flange—2-in., Class 300	8.4 (3,3)
FP	DIN level flange, SST, DN 50, PN 40	7.8 (3,5)
FQ	DIN level flange, SST, DN 80, PN 40	12.7 (5,8)
WSM	SST sensor module	1.0 (0,45)
N/A	Power Module (701PGNKF)	0.4 (0,18)

Product certifications

Rosemount 2051C/T/L

Rev 1.15

European directive information

A copy of the EC Declaration of Conformity can be found at the end of the Quick Start Guide. The most recent revision of the EC Declaration of Conformity can be found at www.Emerson.com.

Ordinary Location Certification

As standard, the transmitter has been examined and tested to determine that the design meets the basic electrical, mechanical, and fire protection requirements by a nationally recognized test laboratory (NRTL) as accredited by the Federal Occupational Safety and Health Administration (OSHA).

Hazardous location certifications

Note

Device ambient temperature ratings and electrical parameters may be limited to the levels dictated by the hazardous location certificate parameters.

North America

E5 USA Explosionproof (XP) and Dust-Ignitionproof (DIP)

Certificate: FM16US0232

Standards: FM Class 3600 – 2011, FM Class 3615 – 2006, FM Class 3616 – 2011, FM Class 3810 – 2005, ANSI/NEMA 250 – 2008, ANSI/IEC 60529 2004

Markings: XP CL I, DIV 1, GP B, C, D; DIP CL II, DIV 1, GP E, F, G; CL III; T5(-50 °C ≤ T_a ≤ +85 °C); Factory Sealed; Type 4X

I5 USA Intrinsic Safety (IS) and Nonincendive (NI)

Certificate: FM16US0231X (HART)

Standards: FM Class 3600 – 2011, FM Class 3610 – 2010, FM Class 3611 – 2004, FM Class 3810 – 2005, ANSI/NEMA 250 – 2008

Markings: IS CL I, DIV 1, GP A, B, C, D; CL II, DIV 1, GP E, F, G; Class III; DIV 1 when connected per Rosemount drawing 02051-1009; Class I, Zone 0; AEx ia IIC T4; NI CL 1, DIV 2, GP A, B, C, D; T4(-50 °C ≤ T_a ≤ +70 °C); Type 4X

Specific Condition of Use (X):

1. The Model 2051 transmitter housing contains aluminum and is considered a potential risk of ignition by impact or friction. Care must be taken into account during installation and use to prevent impact and friction.

Certificate: 2041384 (HART/Fieldbus/Profibus)

Standards: ANSI/ISA 12.27.01-2003, CSA Std. C22.2 No.142-M1987, CSA Std. C22.2. No.157-92

Markings: IS CL I, DIV 1, GP A, B, C, D; CL II, DIV 1, GP E, F, G; Class III; DIV 1 when connected per Rosemount drawing 02051-1009; Class I, Zone 0; AEx ia IIC T4; NI CL 1, DIV 2, GP A, B, C, D; T4(-50 °C ≤ T_a ≤ +70 °C); Type 4x

IE USA FISCO

Certificate: FM16US0231X (HART)

Standards: FM Class 3600 – 2011, FM Class 3610 – 2010, FM Class 3611 – 2004, FM Class 3810 – 2005

Markings: IS CL I, DIV 1, GP A, B, C, D when connected per Rosemount drawing 02051-1009 (-50 °C ≤ T_a ≤ +60 °C); Type 4X

Specific Condition of Use (X):

1. The Model 2051 transmitter housing contains aluminum and is considered a potential risk of ignition by impact or friction. Care must be taken into account during installation and use to prevent impact and friction.

Certificate: 2041384 (HART/Fieldbus/Profibus)

Standards: ANSI/ISA 12.27.01-2003, CSA Std. C22.2 No. 30 -M1986, CSA Std. C22.2 No.142-M1987, CSA Std. C22.2 No. 213 - M1987

Markings: IS CL I, DIV 1, GP A, B, C, D when connected per Rosemount drawing 02051-1009 (-50°C ≤ T_a ≤ +60°C); Type 4x

E6 Canada Explosion-Proof, Dust Ignition Proof

Certificate: 2041384

Standards: CAN/CSA C22.2 No. 0-10, CSA Std C22.2 No. 25-1966, CSA Std C22.2 No. 30-M1986, CAN/CSA-C22.2 No. 94-M91, CSA Std C22.2 No.142-M1987, CAN/CSA-C22.2 No.157-92, CSA Std C22.2 No. 213-M1987, CAN/CSA-E60079-0:07, CAN/CSA-E60079-1:07, CAN/CSA-E60079-11-02, CAN/CSA-C22.2 No. 60529:05, ANSI/ISA-12.27.01-2003

Markings: Explosion-Proof for Class I, Divisions 1, Groups B, C, and D. Dust-Ignition Proof for Class II and Class III, Division 1, Groups E, F, and G. Suitable for Class I, Division 2; Groups A, B, C, and D for indoor and outdoor hazardous locations. Class I Zone 1 Ex d IIC T5. Enclosure type 4X, factory sealed. Single Seal.

I6 Canada Intrinsic Safety

Certificate: 2041384

Standards: CSA Std. C22.2 No. 142 - M1987, CSA Std. C22.2 No. 213 - M1987, CSA Std. C22.2 No. 157 - 92, CSA Std. C22.2 No. 213 - M1987, ANSI/ISA 12.27.01 – 2003, CAN/CSA-E60079-0:07, CAN/CSA-E60079-11:02

Markings: Intrinsically safe for Class I, Division 1, Groups A,B, C, and D when connected in accordance with Rosemount drawing 02051-1008. Ex ia IIC T3C. Single Seal. Enclosure Type 4X.

Europe

E1 ATEX Flameproof

Certificate: KEMA 08ATEX0090X

Standards: EN 60079-0:2012 + A11:2013, EN 60079-1:2014, EN 60079-26:2015

Markings: Ⓜ II 1/2 G Ex db IIC T6 (-60 °C ≤ T_a ≤ +70°C); T4/T5 (-60 °C ≤ T_a ≤ +80 °C)

Table 10: Process Connection Temperature

Temperature class	Process connection temperature	Ambient temperature
T6	-60 °C to +70 °C	-60 °C to +70 °C
T5	-60 °C to +80 °C	-60 °C to +80 °C
T4	-60 °C to +120 °C	-60 °C to +80 °C

Special Conditions for Safe Use (X):

1. Appropriate cable, glands and plugs need to be suitable for a temperature of 5 °C greater than maximum specified temperature for location where installed.
2. Non- standard paint options may cause risk from electrostatic discharge. Avoid installations that could cause electrostatic build-up on painted surfaces, and only clean the painted surfaces with a damp cloth. If paint is ordered through a special option code, contact the manufacturer for more information.

3. The device contains a thin wall diaphragm less than 1 mm thickness that forms a boundary between zone 0 (process connection) and zone 1 (all other parts of the equipment). The model code and datasheet are to be consulted for details of the diaphragm material. Installation, maintenance and use shall take into account the environmental conditions to which the diaphragm shall be subjected. The manufacturer's instructions for installation and maintenance shall be followed in detail to assure safety during its expected lifetime.
4. Flameproof joints are not intended for repair.

I1 ATEX Intrinsic Safety

Certificate: Baseefa08ATEX0129X
Standards: EN60079-0:2012+A11:2013, EN60079-11:2012
Markings: Ⓢ II 1 G Ex ia IIC T4 Ga (-60 °C ≤ T_a ≤ +70 °C)

Table 11: Input Parameters

	HART	Fieldbus/PROFIBUS
Voltage U _i	30 V	30 V
Current I _i	200 mA	300 mA
Power P _i	1 W	1.3 W
Capacitance C _i	0.012 μF	0 μF
Inductance L _i	0 mH	0 mH

Special Condition for Safe Use (X):

1. If the equipment is fitted with an optional 90 V transient suppressor, it is incapable of withstanding the 500 V isolation from earth test and this must be taken into account during installation.
2. The enclosure may be made of aluminum alloy and given a protective polyurethane paint finish; however care should be taken to protect it from impact and abrasion when located in Zone 0.

IA ATEX FISCO

Certificate: Baseefa08ATEX0129X
Standards: EN60079-0:2012+A11:2013, EN60079-11:2012
Markings: Ⓢ II 1 G Ex ia IIC T4 Ga (-60 °C ≤ T_a ≤ +60 °C)

Table 12: Input Parameters

	FISCO
Voltage U _i	17.5 V
Current I _i	380 mA
Power P _i	5.32 W
Capacitance C _i	0 μF
Inductance L _i	0 mH

Special Conditions for Safe Use (X):

1. If the equipment is fitted with an optional 90 V transient suppressor, it is incapable of withstanding the 500 V isolation from earth test and this must be taken into account during installation.

- The enclosure may be made of aluminum alloy and given a protective polyurethane paint finish; however care should be taken to protect it from impact and abrasion when located in Zone 0.

N1 ATEX Type n

Certificate:	Baseefa08ATEX0130X
Standards:	EN60079-0:2012, EN60079-15:2010
Markings:	Ⓜ II 3G Ex nA IIC T4 Gc (-40 °C ≤ T _a ≤ +70 °C)

Special Condition for Safe Use (X):

- If the equipment is fitted with an optional 90 V transient suppressor, it is incapable of withstanding the 500 V electrical strength test as defined in clause 6.5.1 of by EN 60079-15:2010. This must be taken into account during installation.

ND ATEX Dust

Certificate:	Baseefa08ATEX0182X
Standards:	EN60079-0:2012+A11:2013, EN60079-31:2009
Markings:	Ⓜ II 1 D Ex ta IIIC T95 °C T ₅₀₀ 105 °C Da (-20 °C ≤ T _a ≤ +85 °C)

Special Condition for Safe Use (X):

- If the equipment is fitted with an optional 90 V transient suppressor, it is incapable of withstanding the 500 V isolation from earth test and this must be taken into account during installation.

International

E7 IECEx Flameproof

Certificate:	IECExKEM08.0024X
Standards:	IEC 60079-0:2011, IEC 60079-1:2014-06, IEC 60079-26:2014-10
Markings:	Ex db IIC T6... T4 Ga/Gb T6(-60 °C ≤ T _a ≤ +70 °C), T4/T5(-60 °C ≤ T _a ≤ +80 °C)

Table 13: Process Connection Temperature

Temperature class	Process connection temperature	Ambient temperature
T6	-60 °C to +70 °C	-60 °C to +70 °C
T5	-60 °C to +80 °C	-60 °C to +80 °C
T4	-60 °C to +120 °C	-60 °C to +80 °C

Special Conditions for Safe Use (X):

- The device contains a thin wall diaphragm less than 1 mm thickness that forms a boundary between zone 0 (process connection) and zone 1 (all other parts of the equipment). The model code and datasheet are to be consulted for details of the diaphragm material. Installation, maintenance and use shall take into account the environmental conditions to which the diaphragm shall be subjected. The manufacturer's instructions for installation and maintenance shall be followed in detail to assure safety during its expected lifetime.
- Appropriate cable, glands and plugs need to be suitable for a temperature of 5 °C greater than maximum specified temperature for location where installed.
- Flameproof joints are not intended for repair.
- Non-standard paint options may cause risk from electrostatic discharge. Avoid installations that could cause electrostatic build-up on painted surfaces, and only clean the painted surfaces with a damp cloth. If paint is ordered through a special option code, contact the manufacturer for more information.

I7 IECEx Intrinsic Safety

Certificate: IECExBAS 08.0045X
Standards: IEC60079-0:2011, IEC60079-11:2011
Markings: Ex ia IIC T4 Ga (-60 °C ≤ T_a ≤ +70 °C)

Table 14: Input Parameters

	HART	Fieldbus/PROFIBUS
Voltage U _i	30 V	30 V
Current I _i	200 mA	300 mA
Power P _i	1 W	1.3 W
Capacitance C _i	12 nF	0 μF
Inductance L _i	0 mH	0 mH

Special Condition for Safe Use (X):

1. If the equipment is fitted with an optional 90 V transient suppressor, it is incapable of withstanding the 500 V isolation from earth test and this must be taken into account during installation.
2. The enclosure may be made of aluminum alloy and given a protective polyurethane paint finish; however care should be taken to protect it from impact and abrasion when located in Zone 0.
3. The equipment contains thin wall diaphragms. The installation, maintenance and use shall take into account the environmental conditions to which the diaphragms will be subjected. The manufacturer’s instructions for installation and maintenance shall be followed in detail to assure safety during its expected lifetime.

IG IECEx FISCO

Certificate: IECExBAS 08.0045X
Standards: IEC60079-0:2011, IEC60079-11:2011
Markings: Ex ia IIC T4 Ga (-60 °C ≤ T_a ≤ +60 °C)

Table 15: Input Parameters

	FISCO
Voltage U _i	17.5 V
Current I _i	380 mA
Power P _i	5.32 W
Capacitance C _i	0 nF
Inductance L _i	0 μH

Special Condition for Safe Use (X):

1. If the equipment is fitted with an optional 90 V transient suppressor, it is incapable of withstanding the 500 V isolation from earth test and this must be taken into account during installation.
2. The enclosure may be made of aluminum alloy and given a protective polyurethane paint finish; however care should be taken to protect it from impact and abrasion when located in Zone 0.
3. The equipment contains thin wall diaphragms. The installation, maintenance and use shall take into account the environmental conditions to which the diaphragms will be subjected. The manufacturer’s instructions for installation and maintenance shall be followed in detail to assure safety during its expected lifetime.

N7 IECEx Type n

Certificate:	IECExBAS 08.0046X
Standards:	IEC60079-0:2011, IEC60079-15:2010
Markings:	Ex nA IIC T4 Gc ($-40\text{ °C} \leq T_a \leq +70\text{ °C}$)

Special Condition for Safe Use (X):

1. If fitted with a 90 V transient suppressor, the equipment is not capable of withstanding the 500 V electrical strength test as defined in clause 6.5.1 of IEC60079-15:2010. This must be taken into account during installation.

Brazil**E2 INMETRO Flameproof**

Certificate:	UL-BR 14.0375X
Standards:	ABNT NBR IEC60079-0:2008 + Errata 1:2011, ABNT NBR IEC 60079-1:2009 + Errata 1:2011, ABNT NBR IEC 60079-26:2008 + Errata 1:2009
Markings:	Ex db IIC T6...T4 Ga/Gb IP66, T6($-60\text{ °C} \leq T_a \leq +70\text{ °C}$), T4/T5($-60\text{ °C} \leq T_a \leq +80\text{ °C}$)

Special Conditions for Safe Use (X):

1. The device contains a thin wall diaphragm. Installation, maintenance and use shall take into account the environmental conditions to which the diaphragm will be subjected. The manufacturer's instructions for installation and maintenance shall be followed in detail to assure safety during its expected lifetime.
2. Flameproof joints are not intended for repair.
3. Non-standard paint options may cause risk from electrostatic discharge. Avoid installations that could cause electrostatic build-up on painted surfaces, and only clean the painted surfaces with a damp cloth. If paint is ordered through a special option code, contact the manufacturer for more information.

I2 INMETRO Intrinsic Safety

Certificate:	UL-BR 14.0759X
Standards:	ABNT NBR IEC 60079-0:2013; ABNT NBR IEC 60079-11:2013
Markings:	Ex ia IIC T4 Ga ($-60\text{ °C} \leq T_a \leq +70\text{ °C}$)

Table 16: Input Parameters

	HART	Fieldbus/PROFIBUS
Voltage U_i	30 V	30 V
Current I_i	200 mA	300 mA
Power P_i	1 W	1.3 W
Capacitance C_i	12 nF	0
Inductance L_i	0	0

Special Conditions for Safe Use (X):

1. If the equipment is fitted with an optional 90 V transient suppressor, it is incapable of withstanding the 500 V insulation from earth test and this must be taken into account during installation.
2. The enclosure may be made of aluminium alloy and given a protective polyurethane paint finish; however care should be taken to protect it from impact and abrasion when located in atmospheres that require ELP Ga.

IB INMETRO FISCO

- Certificate:** UL-BR 14.0759X
Standards: ABNT NBR IEC 60079-0:2008 + Errata 1:2011; ABNT NBR IEC 60079-11:2009
Markings: Ex ia IIC T4 Ga (-60 °C ≤ T_a ≤ +60 °C)

Table 17: Input Parameters

	FISCO
Voltage U _i	17.5 V
Current I _i	380 mA
Power P _i	5.32 W
Capacitance C _i	0 nF
Inductance L _i	0 μH

Special Conditions for Safe Use (X):

1. If the equipment is fitted with an optional 90 V transient suppressor, it is incapable of withstanding the 500 V insulation from earth test and this must be taken into account during installation.
2. The enclosure may be made of aluminium alloy and given a protective polyurethane paint finish; however care should be taken to protect it from impact and abrasion when located in atmospheres that require ELP Ga.

China

E3 China Flameproof

- Certificate:** GYJ18.1432X; GYJ20.1485X [Flowmeters]
Standards: GB3836.1-2010, GB3836.2-2010, GB3836.20-2010-2010
Markings: Pressure Transmitter: Ex d IIC Gb, T6~T4 Ga/Gb
 Flow meter: Ex d IIC T5/T6 Ga/Gb

一、产品安全使用特殊条件

证书编号后缀“X”表明产品具有安全使用特殊条件：

1. 涉及隔爆接合面的维修须联系产品制造商。
2. 产品使用厚度小于 1mm 的隔膜作为 0 区（过程连接）和 1 区（产品其他部分）的隔离，安装和维护时严格遵守制造商提供的说明书，一确保安全。
3. 产品外部涂层可能产生静电危险，使用时须防止产生静电火花，只能用湿布清理

二、产品使用注意事项

1. 1. 产品温度组别和使用环境温度之间的关系为：

温度组别	使用环境温度	过程温度
T6	-60°C ~ +70°C	-60°C ~ +70°C
T5	-60°C ~ +80°C	-60°C ~ +80°C
T4	-60°C ~ +80°C	-60°C ~ +120°C

2. 产品外壳设有接地端子，用户在使用时应可靠接地。

3. 安装现场应不存在对产品外壳有腐蚀作用的有害气体。
4. 现场安装时，电缆引入口须选用经国家指定防爆检验机构检验认可、具有 Ex dIIC Gb 防爆等级的电缆引入装置或堵封件，冗余电缆引入口须用堵封件有效密封。
5. 用于爆炸性气体环境中，现场安装、使用和维护必须严格遵守“严禁带电开盖！”的警告语。
6. 用户不得自行更换该产品的零部件，应会同产品制造商共同解决运行中出现的故障，以杜绝损坏现象的发生。
7. 产品的安装、使用和维护应同时遵守产品使用说明书、GB3836.13-2013“爆炸性环境 第 13 部分：设备的修理、检修、修复和改造”、GB3836.15-2017“爆炸性环境 第 15 部分：电气装置的设计、选型和安装”、GB3836.16-2017“爆炸性环境 第 16 部分：电气装置的检查和维护”和 GB50257-2014“电气装置安装工程爆炸和火灾危险环境电力装置施工及验收规范”的有关规定。

13 China Intrinsic Safety

Certificate: GYJ17.1225X; GYJ15.1365X [Flow meters]
Standards: GB3836.1-2010, GB3836.4-2010, GB3836.20-2010
Markings: Ex ia IIC T4 Ga

一、产品安全使用特殊条件

产品防爆合格证号后缀“X”代表产品安全使用有特殊条件：

1. 产品选用铝合金外壳，使用时需注意防止由于冲击或摩擦产生的点燃危险。
2. 当选择 T1 瞬态抑制端子时此设备不能承受 GB3836.4-2010 标准中第 6.3.12 条规定的 500V 交流有效值试验电压的介电强度试验。
3. 当输出选项代码为 X 时，需使用由厂家提供的型号为 701PG 的 SmartPower Green Power Module 电池。产品外壳含有非金属部件，使用时须防止产生静电火花，只能用湿布清理。

二、产品使用注意事项

1. Transmitter output	环境温度范围
A、F、W、M	-60°C ~ +70°C
F、W (FISCO)	-60°C ~ +60°C
X	-40°C ~ +70°C

2. 本安电气参数：

Transmitter output	最高输入电压 Ui (V)	最大输入电流 Ii (mA)	最大输入功率 Pi (W)	最大内部等效参数	
				Ci(nF)	Li(μH)
A、M	30	200	1.0	12	0
F、W	30	300	1.3	0	0
F、W (FISCO)	17.5	380	5.32	0	0

Note

注：c Transmitter Output 为 F、W (FISCO) 时，本安电气参数符合 GB3836.19-2010 对 FISCO 现场仪表的参数要求。

3. 该产品必须与已通过防爆认证的关联设备配套共同组成本安防爆系统方可使用于爆炸性气体环境。其系统接线必须同时遵守本产品和所配关联设备的使用说明书要求，接线端子不得接错。
4. 用户不得自行更换该产品的零部件，应会同产品制造商共同解决运行中出现的故障，以杜绝损坏现象的发生。

5. 产品的安装、使用和维护应同时遵守产品使用说明书、GB3836.13-2013“爆炸性环境 第13部分：设备的修理、检修、修复和改造”、GB3836.15-2000“爆炸性气体环境用电气设备 第15部分：危险场所电气安装（煤矿除外）”、GB3836.16-2006“爆炸性气体环境用电气设备 第16部分：电气装置的检查和维护（煤矿除外）”、GB3836.18-2010“爆炸性环境 第18部分：本质安全系统”和GB50257-2014“电气装置安装工程爆炸和火灾危险环境电力装置施工及验收规范”的有关规定。

Korea

EP Korea Flameproof

Certificate: 12-KB4BO-0342X, 12-KB4BO-0344X, 19-KB4BO-0978X

Markings: Ex d IIC T6...T4 Ga/Gb, T4/T5(-60 °C ≤ T_a ≤ +80 °C), T6(-60 °C ≤ T_a ≤ +70 °C)

Special Condition for Safe Use (X)

1. See certificate for special conditions.

IP Korea Intrinsic Safety

Certificate: 12-KB4BO-0343X, 12-KB4BO-0345X, 13-KB4BO-0205X, 13-KB4BO-0207X, 18-KA4BO-0309X

Markings: Ex ia IIC T4 Ga (-60 °C ≤ T_a ≤ +70 °C)

Special Condition for Safe Use (X):

1. See certificate for special conditions.

Japan

E4 Japan Flameproof

Certificate: TC20598, TC20599, TC20602, TC20603 [HART]; TC20600, TC20601, TC20604, TC20605 [Fieldbus]

Markings: Ex d IIC T5

Technical Regulations Customs Union (EAC)

EM EAC Flameproof

Certificate: TC RU C-US.AA87.B.00588

Markings: Ga/Gb Ex d IIC X, T5 (-50 °C ≤ T_a ≤ +80 °C), T6 (-50 °C ≤ T_a ≤ +65 °C)

Special Condition for Safe Use (X):

1. See certificate for special conditions.

IM EAC Intrinsically Safe

Certificate: TC RU C-US.AA87.B.00588

Markings: 0Ex ia IIC T4 Ga X (-60 °C ≤ T_a ≤ +70 °C)

Special Condition for Safe Use (X):

1. See certificate for special conditions.

Combinations

K1 combination of E1, I1, N1, and ND

K2 combination of E2 and I2

K5 combination of E5 and I5

K6 combination of E6 and I6

K7 combination of E7, I7, N7 and IECEx Dust

IECEx Dust

Certificate:	IECExBAS 08.0058X
Standards:	IEC60079-0:2011, IEC60079-31:2008
Markings:	Ex tA IIIC T95 °C T500 105 °C Da (-20 °C ≤ T _a ≤ +85 °C)

Special Condition for Safe Use (X):

1. If the equipment is fitted with an optional 90 V transient suppressor, it is incapable of withstanding a 500 V isolation from earth test and this must be taken into account during installation.

KA combination of E1, I1, and K6

KB combination of K5 and K6

KC combination of E1, I1, and K5

KD combination of K1, K5, and K6

KP combination of EP and IP

KM Combination of EM and IM

Additional Certifications

SBS American Bureau of Shipping (ABS) Type Approval

Certificate:	18-HS1753847-PDA
Intended Use:	Marine and Offshore Applications Measurement of either Gauge or Absolute Pressure for Liquid, Gas, and Vapor
ABS Rules:	2018 Steel Vessels Rules 1-1-4/7.7, 1-1-Appendix 3, 1-1-Appendix 4

SBV Bureau Veritas (BV) Type Approval

Certificate:	23157 BV
BV Rules:	Bureau Veritas Rules for the Classification of Steel Ships
Application:	Class notations: AUT-UMS, AUT-CCS, AUT-PORT and AUT-IMS; Pressure transmitter type 2051 cannot be installed on diesel engines.

SDN Det Norske Veritas (DNV) Type Approval

Certificate:	TAA00004F
Intended Use:	DNV GL Rules for Classification — Ships and offshore units

Application:

Location classes	
Type	2051
Temperature	D
Humidity	B
Vibration	A
EMC	B
Enclosure	D

SLL Lloyds Register (LR) Type Approval

Certificate: 11/60002

Application: Environmental categories ENV1, ENV2, ENV3, and ENV5

Rosemount 2051G

Rev 1.6

European Directive Information

A copy of the EU Declaration of Conformity can be found at the end of the Quick Start Guide. The most recent revision of the EU Declaration of Conformity can be found at Emerson.com/Rosemount.

North America

E5 USA Explosionproof (XP) and Dust-Ignitionproof (DIP)

Certificate 1015441

Standards FM Class 3600 – 2011, FM, Class 3615 – 2006, FM Class 3616 – 2011, FM Class 3810 – 2005

Markings XP CL I, DIV 1, GP B, C, D; DIP CL II, DIV 1, GP E, F, G; CL III; T5(-50°C ≤ Ta ≤ +85°C); Factory Sealed; Type 4X

I5 USA Intrinsic Safety (IS) and Nonincendive (NI)

Certificate 1015441

Standards FM Class 3600 – 2011, FM Class 3610 – 2010, FM Class 3611 – 2004, FM Class 3810 – 2005

Markings IS CL I, DIV 1, GP A, B, C, D; CL II, DIV 1, GP E, F, G; Class III; DIV 1 when connected per Rosemount drawing 02088-1024; NI CL 1, DIV 2, GP A, B, C, D; T4(-50°C ≤ Ta ≤ +70°C); Type 4x

E6 Canada Explosionproof, Division 2, Dust-Ignitionproof

Certificate 1015441

Standards CAN/CSA C22.2 No. 0-M91 (R2001), CSA Std C22.2 No. 25-1966, CSA Std C22.2 No. 30-M1986, CAN/CSA-C22.2 No. 94-M91, CSA Std C22.2 No. 142-M1987, CAN/CSA-C22.2 No. 157-92, CSA Std C22.2 No. 213-M1987, ANSI-ISA-12.27.01-2003

Markings Class I, Division 1, Groups B, C and D; Class II, Groups E, F, and G; Class III; Class I Division 2 Groups A, B, C and D; Type 4X; Factory Sealed; Single Seal

I6 Canada Intrinsic Safety

Certificate 1015441

Standards CAN/CSA C22.2 No. 0-M91 (R2001), CSA Std C22.2 No. 25-1966, CSA Std C22.2 No. 30-M1986, CAN/CSA-C22.2 No. 94-M91, CSA Std C22.2 No. 142-M1987, CAN/CSA-C22.2 No. 157-92, CSA Std C22.2 No. 213-M1987, ANSI-ISA-12.27.01-2003

Markings Intrinsically Safe Class I, Division 1 when connected in accordance with Rosemount drawing 02088-1024, Temperature Code T4; Ex ia; Type 4X; Factory Sealed; Single Seal

Europe

E1 ATEX Flameproof

Certificate KEMA97ATEX2378X

Standards EN 60079-0:2012 + A11:2013, EN60079-1:2014, EN60079-26:2015

Markings ⓈII 1/2 G Ex db IIC T6..T4 Ga/Gb, T6(-60 °C ≤ Ta ≤ +70 °C), T5/T4 (-60 °C ≤ Ta ≤ +80 °C)

Table 18: Process Connection Temperature

Temperature class	Process connection temperature	Ambient temperature
T6	-60 to +70 °C	-60 to +70 °C
T5	-60 to +80 °C	-60 to +80 °C
T4	-60 to +120 °C	-60 to +80 °C

Special Conditions for Safe Use (X):

1. This device contains a thin wall diaphragm less than 1 mm thickness that forms a boundary between zone 0 (process connection) and zone 1 (all other parts of the equipment). The model code and data sheet are to be consulted for details of the diaphragm material. Installation, maintenance and use shall take into account the environmental conditions to which the diaphragm will be subjected. The manufacturer's instructions for installation and maintenance shall be followed in detail to assure safety during its expected lifetime.
2. Flameproof joints are not intended for repair.
3. Non-standard paint options may cause risk from electrostatic discharge. Avoid installations that could cause electrostatic build-up on painted surfaces, and only clean the painted surfaces with a damp cloth. If paint is ordered through a special option code, contact the manufacturer for more information.
4. Appropriate cable, glands and plugs need to be suitable for a temperature of 5 °C greater than maximum specified temperature for location where installed.

I1 ATEX Flameproof

- Certificate** BAS00ATEX1166X
- Standards** EN60079-0:2012 + A11:2013, EN60079-11:2012
- Markings** Ⓜ II 1 G Ex ia IIC T4 Ga (-55 °C ≤ Ta ≤ +70 °C)

Table 19: Input Parameters

Parameter	HART
Voltage U _i	30 V
Current I _i	200 mA
Power P _i	0.9 W
Capacitance C _i	0.012 μF

Special Conditions for Safe Use (X):

1. The apparatus is not capable of withstanding the 500 V insulation test required by EN60079-11. This must be taken into account when installing the apparatus.
2. The enclosure may be made of aluminum alloy and given a protective polyurethane paint finish; however, care should be taken to protect it from impact or abrasion if located in a Zone 0 environment.

N1 ATEX Type n

- Certificate** BAS00ATEX3167X
- Standards** EN60079-0:2012 + A11:2013, EN60079-15:2010
- Markings** Ⓜ II 3 G Ex nA IIC T5 Gc (-55 °C ≤ Ta ≤ +70 °C)

Special Condition for Safe Use (X):

1. This apparatus is not capable of withstanding the 500V insulation test required by EN60079-15. This must be taken into account when installing the apparatus.

ND ATEX Dust

Certificate: BAS01ATEX1427X
Standards: EN60079-0:2012 + A11:2013, EN60079-31:2009
Markings: Ⓢ II 1 D Ex t IIIC T50 °C T₅₀₀ 60 °C Da

Special Conditions for Safe Use (X):

1. Cable entries must be used which maintain the ingress protection of the enclosure to at least IP66.
2. Unused cable entries must be filled with suitable blanking plugs which maintain the ingress protection of the enclosure to at least IP66.
3. Cable entries and blanking plugs must be suitable for the ambient range of the apparatus and capable of withstanding a 7J impact test.

International

E7 IECEx Flameproof

Certificate: IECEx KEM 06.0021X
Standards: IEC 60079-0:2011, IEC 60079-1:2014, IEC 60079-26:2014
Markings: Ex db IIC T6...T4 Ga/Gb
 T6(-60 °C ≤ T_a ≤ +70 °C),
 T5/T4(-60 °C ≤ T_a ≤ +80 °C)

Table 20: Process Connection Temperature

Temperature class	Process connection temperature	Ambient temperature
T6	-60 to +70 °C	
T5	-60 to +80 °C	
T4	-60 to +120 °C	-60 to +80 °C

Special Conditions for Safe Use (X):

1. This device contains a thin wall diaphragm less than 1 mm thickness that forms a boundary between zone 0 (process connection) and zone 1 (all other parts of the equipment). The model code and data sheet are to be consulted for details of the diaphragm material. Installation, maintenance and use shall take into account the environmental conditions to which the diaphragm will be subjected. The manufacturer's instructions for installation and maintenance shall be followed in detail to assure safety during its expected lifetime.
2. Flameproof joints are not intended for repair.
3. Non-standard paint options may cause risk from electrostatic discharge. Avoid installations that could cause electrostatic build-up on painted surfaces, and only clean the painted surfaces with a damp cloth. If paint is ordered through a special option code, contact the manufacturer for more information.
4. Appropriate cable, glands and plugs need to be suitable for a temperature of 5°C greater than maximum specified temperature for location where installed.

I7 IECEx Intrinsic Safety

Certificate: IECEx BAS 12.0071X
Standards: IEC60079-0:2011, IEC60079-11:2011
Markings: Ex ia IIC T4 Ga (-55 °C ≤ T_a ≤ +70 °C)

Table 21: Input Parameters

Voltage U _i	30 V
Current I _i	200 mA
Power P _i	0.9 W
Capacitance C _i	0.012 μF

Special Conditions for Safe Use (X):

1. When fitted with a transient suppression terminal block, the Rosemount™ 2088 is incapable of passing the 500 V isolation test. This must be taken into account during installation.
2. The enclosure may be made of aluminum alloy and given a protective polyurethane paint finish; however, care should be taken to protect it from impact or abrasion if located in a Zone 0 environment.

N7 IECEx Type n

Certificate: IECEx BAS 12.0072X
Standards: IEC60079-0:2011, IEC60079-15:2010
Markings: Ex nA IIC T5 Gc (-40 °C ≤ T_a ≤ +70 °C)

Special Condition for Safe Use (X):

1. When fitted with a transient suppression terminal block, the Rosemount 2088 is incapable of passing the 500 sV isolation test. This must be taken into account during installation.

NK IECEx Dust

Certificate: IECEx BAS12.0073X
Standards: IEC60079-0:2011, IEC60079-31:2008
Markings: Ex t IIIC T55 °C ≤ T₅₀₀ 60 °C Da

Table 22: Input Parameters

	HART®
Voltage U _i	36 V
Current I _i	24 mA

Special Conditions for Safe Use (X):

1. Cable entries must be used which maintain the ingress protection of the enclosure to at least IP66.
2. Unused cable entries must be filled with suitable blanking plugs which maintain the ingress protection of the enclosure to at least IP66.
3. Cable entries and blanking plugs must be suitable for the ambient range of the apparatus and capable of withstanding a 7J impact test.

Brazil

E2 INMETRO Flameproof

- Certificate:** UL-BR 15.0728X
- Standards:** ABNT NBR IEC 60079-0:2013, ABNT NBR IEC 60079-1:2016, ABNT NBR IEC 60079-26:2016
- Markings:** Ex db IIC T6...T4 Ga/Gb T4/T5($-60\text{ °C} \leq T_a \leq +80\text{ °C}$),
T6($-60\text{ °C} \leq T_a \leq +70\text{ °C}$)

Special Conditions for Safe Use (X):

1. This device contains a thin wall diaphragm less than 1 mm thickness that forms a boundary between zone 0 (process connection) and zone 1 (all other parts of the equipment). The model code and data sheet are to be consulted for details of the diaphragm material. Installation, maintenance and use shall take into account the environmental conditions to which the diaphragm will be subjected. The manufacturer's instructions for installation and maintenance shall be followed in detail to assure safety during its expected lifetime.
2. Flameproof joints are not intended for repair.
3. Non-standard paint options may cause risk from electrostatic discharge. Avoid installations that could cause electrostatic build-up on painted surfaces, and only clean the painted surfaces with a damp cloth. If paint is ordered through a special option code, contact the manufacturer for more information.

I2 INMETRO Intrinsic Safety

- Certificate:** UL-BR 13.0246X
- Standards:** ABNT NBR IEC60079-0:2008 + Errata 1:2011, ABNT NBR IEC60079-11:2009
- Markings:** Ex ia IIC T4 Ga ($-55\text{ °C} \leq T_a \leq +70\text{ °C}$),
T6($-60\text{ °C} \leq T_a \leq +70\text{ °C}$)

Table 23: Input Parameters

Voltage U_i	30 V
Current I_i	200 mA
Power P_i	0.9 W
Capacitance C_i	0.012 μ F
Inductance L_i	0 mH

Special Conditions for Safe Use (X):

1. When fitted with a transient suppression terminal block, the Rosemount™ 2088 is incapable of passing the 500 V isolation test. This must be taken into account during installation.
2. The enclosure may be made of aluminum alloy and given a protective polyurethane paint finish; however, care should be taken to protect it from impact or abrasion if located in a zone 0 environment (areas that require EPL Ga).

China

E3 China Flameproof

- Certificate:** GYJ17.1158X
- Standards:** GB3836.1-2010, GB3836.2-2010, GB3836.20-2010
- Markings:** : Ex d IIC T6~T4 Ga/Gb, T5/T4($-60\text{ °C} \leq T_a \leq +80\text{ °C}$), T6($-60\text{ °C} \leq T_a \leq +70\text{ °C}$)

Special Condition for Safe Use (X):

1. Contact the original manufacturer when repair work relates to the flamepath.

I3 China Intrinsic Safety

Certificate:	GYJ17.1157X
Standards:	GB3836.1-2010, GB3836.4-2010, GB3836.20-2010
Markings:	Ex ia IIC T4 Ga (-55 °C ≤ T _a ≤ +70 °C)

Special Conditions for Safe Use (X):

1. The enclosure may contain light metal, attention should be taken to avoid ignition hazard due to impact or friction when used in Zone 0.
2. When transient protection board is chosen (option code T1), this apparatus is not capable of withstanding the 500 V r.m.s insulation test required by clause 6.3.12 of GB3836.4-2010.

N3 China Type n

Certificate:	GYJ17.1159X
Standards:	GB3836.1-2010, GB3836.8-2014
Markings:	Ex nA IIC T5 Gc (-40 °C ≤ T _a ≤ +70 °C)

Special Condition for Safe Use (X):

1. When transient protection board is chosen (option code T1), this apparatus is not capable of withstanding the 500 V r.m.s insulation test required by Clause 6.3.12 of GB3836.4-2010.

Technical Regulations Customs Union (EAC)**EM EAC Flameproof**

Certificate	EAEC RU C-US.EX01.B.00176
Standards	GB3836.1-2010, GB3836.2-2010, GB3836.20-2010
Markings	:Ga/Gb Ex db IIC T5/T6 X, T5(-60 °C ≤ T _a ≤ +80 °C), T6(-60 °C ≤ T _a ≤ +70 °C)

Special Condition for Safe Use (X):

1. See certificate for special conditions.

IM EAC Intrinsic Safety

Certificate	EAEC RU C-US.EX01.B.00176
Standards	GB3836.1-2010, GB3836.4-2010, GB3836.20-2010
Markings	0Ex ia IIC T4 Ga X, T4(-55 °C ≤ T _a ≤ +70 °C)

Special Conditions for Safe Use (X):

1. See certificate for special conditions.

Combinations

K1	Combination of E1, I1, N1, and ND
K2	Combination of E2 and I2

K3	Combination of E3 and I3
K5	Combination of E5 and I5
K6	Combination of E6 and I6
K7	Combination of E7, I7, N7, and NK
KB	Combination of K5 and K6
KD	Combination of E1, I1, K5 and K6
KM	Combination of EM and IM

Conduit plugs and adapters

IECEx Flameproof and Increased Safety

Certificate:	IECEx FMG 13.0032X
Standards:	IEC60079-0:2011, IEC60079-1:2007, IEC60079-7:2006-2007
Markings:	Ex d e IIC Gb

ATEX Flameproof and Increased Safety

Certificate:	FM13ATEX0076X
Standards:	EN60079-0:2012, EN60079-1:2007, IEC60079-7:2007
Markings:	Ⓔ II 2 G Ex d e IIC Gb

Table 24: Conduit Plug Thread Sizes

Thread	Identification mark
M20 x 1.5	M20
½ – 14 NPT	½ NPT
G½	G½

Table 25: Thread Adapter Thread Sizes

Male thread	Identification mark
M20 x 1.5 – 6H	M20
½ – 14 NPT	½ – 14 NPT
¾ – 14 NPT	¾ – 14 NPT
Female thread	Identification mark
M20 x 1.5 – 6H	M20
½ – 14 NPT	½ – 14 NPT
G½	G½

Special Conditions for Safe Use (X):

1. When the thread adapter or blanking plug is used with an enclosure in type of protection increased safety “e” the entry thread shall be suitably sealed in order to maintain the ingress protection rating (IP) of the enclosure.
2. The blanking plug shall not be used with an adapter.

3. Blanking plug and threaded adapter shall be either NPT or metric thread forms. G½ thread forms are only acceptable for existing (legacy) equipment installations.

Rosemount 2051 Wireless

Rev 1.7

European Directive Information

A copy of the EU Declaration of Conformity can be found at the end of the Quick Start Guide. The most recent revision of the EU Declaration of Conformity can be found at [Emerson.com/Rosemount](https://www.emerson.com/Rosemount).

Telecommunication compliance

All wireless devices require certification to ensure that they adhere to regulations regarding the use of the RF spectrum. Nearly every country requires this type of product certification. Emerson is working with governmental agencies around the world to supply fully compliant products and remove the risk of violating country directives or laws governing wireless device usage.

FCC and IC

This device complies with Part 15 of the FCC Rules. Operation is subject to the following conditions: This device may not cause harmful interference. This device must accept any interference received, including interference that may cause undesired operation. This device must be installed to ensure a minimum antenna separation distance of 20 cm from all persons.

Ordinary Location Certification

As standard, the transmitter has been examined and tested to determine that the design meets the basic electrical, mechanical, and fire protection requirements by a nationally recognized test laboratory (NRTL) as accredited by the Federal Occupational Safety and Health Administration (OSHA).

Installing in North America

The US National Electrical Code[®] (NEC) and the Canadian Electrical Code (CEC) permit the use of Division marked equipment in Zones and Zone marked equipment in Divisions. The markings must be suitable for the area classification, gas, and temperature class. This information is clearly defined in the respective codes.

USA

I5 U.S.A. Intrinsically Safe (IS)

Certificate: FM19US0050X

Standards: FM Class 3600 – 2018, FM Class 3610 – 2018, FM Class 3810 – 2018, ANSI/ISA 60079-0:2013, ANSI/UL 60079-11:2014, NEMA 250: 2003, ANSI/IEC 60529:2014, ANSI/UL 61010:2016

Markings: IS CL I, DIV 1, GP A, B, C, D T4; CL 1, Zone 0 AEx ia IIC T4; T4 (–40 °C ≤ T_a ≤ +70 °C) when installed per Rosemount drawing 03031-1062; Type 4X/IP66/IP68

Special Conditions for Safe Use (X):

1. The Rosemount 2051 Wireless Pressure Transmitter shall only be used with the 701PGNKF Rosemount SmartPower™ Battery Pack.
2. The inline pressure sensor may contain more than 10 percent aluminum and is considered a potential risk of ignition by impact or friction. Care must be taken into account during installation and used to prevent impact and friction.
3. The surface resistivity of the transmitter housing is greater than one gigaohm. To avoid electrostatic charge build-up, it must not be rubbed or cleaned with solvents or a dry cloth.

Canada

I6 Canada Intrinsically Safe

Certificate: CSA 2526009

Standards: CAN/CSA C22.2 No. 0-M91, CAN/CSA C22.2 No. 94-M91, CSA Std C22.2 No. 142-M1987, CSA Std C22.2 No. 157-92, CSA Std C22.2 No. 60529:05

Markings: Intrinsically Safe for Class I, Division 1, Groups A, B, C, D, T4 when installed per Rosemount drawing 03031-1063; Type 4X/IP66/IP68

Europe

I1 ATEX Intrinsic Safety

Certificate: Baseefa12ATEX0228X

Standards: EN 60079-0:2012, EN 60079-11:2012

Markings: Ⓔ II 1 G Ex ia IIC T4 Ga, T4 ($-40\text{ °C} \leq T_a \leq +70\text{ °C}$) IP66/IP68

Special Conditions for Safe Use (X):

1. The plastic enclosure may constitute a potential electrostatic ignition risk and must not be rubbed or cleaned with a dry cloth.
2. The Rosemount 701PGNKF Power Module may be replaced in a hazardous area. The power module has a surface resistivity greater than $1\text{ G}\Omega$ and must be properly installed in the wireless device enclosure. Care must be taken during transportation to and from the point of installation to prevent electrostatic charge build-up.

International

I7 IECEx Intrinsic Safety

Certificate: IECEx BAS 12.0124X

Standards: IEC 60079-0:2011, IEC 60079-11:2011

Markings: Ex ia IIC T4 Ga, T4 ($-40\text{ °C} \leq T_a \leq +70\text{ °C}$) IP66/IP68

Special Conditions for Safe Use (X):

1. The plastic enclosure may constitute a potential electrostatic ignition risk and must not be rubbed or cleaned with a dry cloth.
2. The Rosemount 701PGNKF Power Module may be replaced in a hazardous area. The power module has a surface resistivity greater than $1\text{ G}\Omega$ and must be properly installed in the wireless device enclosure. Care must be taken during transportation to and from the point of installation to prevent electrostatic charge build-up.

Brazil

I2 INMETRO Intrinsic Safety

Certificate: UL-BR 13.0534X

Standards: ABNT NBR IEC 60079-0:2008 + Errata 1:2011, ABNT NBR IEC 60079-11:2009

Markings: Ex ia IIC T4 IP66 Ga, T4 ($-40\text{ °C} \leq T_a \leq +70\text{ °C}$)

Special Condition for Safe Use (X):

1. See certificate for special conditions.

China

I3 China Intrinsic Safety

Certificate: GYJ17.1225X GYJ15.1365X [Flow meters]
Standards: GB3836.1-2010, GB3836.4-2010, GB3836.20-2010
Markings: Ex ia IIC Ga T4, -40 ~ +70°C

Special Condition for Safe Use (X):

1. See certificate for special conditions.

Japan

I4 TIIS Intrinsic Safety

Certificate: TC22022X (Rosemount™ 2051C/L) TC22023X (Rosemount 2051T) TC22024X (Rosemount 2051CFx)
Markings: Ex ia IIC T4 Ga, T4 (-20 ~ +60 °C)

Special Condition for Safe Use (X):

1. See certificate for special conditions.

EAC - Belarus, Kazakhstan, Russia

IM Technical Regulation Customs Union (EAC) Intrinsic Safety

Certificate: TC RU C-US.AA87.B.00588
Markings: 0Ex ia IIC T4 Ga X; (-40°C ≤ T_a ≤ +70°C)

Special Condition for Safe Use (X):

1. See certificate for special conditions.

Korea

IP Korea Intrinsic Safety

Certificate: 13-KB4BO-0220X
Markings: Ex ia IIC T4 (-40 °C ≤ T_a ≤ +70 °C)

Special Condition for Safe Use (X):

1. See certificate for special conditions.

Additional certifications

SBS American Bureau of Shipping (ABS) Type Approval

Certificate: 15-HS1405241-PDA
Intended use: Marine & Offshore Applications – Measurement of either gauge or absolute pressure for liquid, gas and vapor.
ABS rules: 2015 Steel Vessels Rules 1-1-4/7.7, 1-1-Appendix 3, 1-1-Appendix 4

SBV Bureau Veritas (BV) Type Approval**Certificate:** 23157 BV**BV rules:** Bureau Veritas Rules for the Classification of Steel Ships**Application:** Class notations: AUT-UMS, AUT-CCS, AUT-PORT and AUT-IMS; Pressure transmitter type 2051 cannot be installed on diesel engines.**SDN Det Norske Veritas (DNV) Type Approval****Certificate:** TAA000004F**Intended use:** DNV GL Rules for Classification - Ships and offshore units**Application:**

Location classes	
Type	2051
Temperature	B
Humidity	B
Vibration	A
EMC	B
Enclosure	D

Dimensional drawings

Figure 8: Rosemount 2051C Exploded View

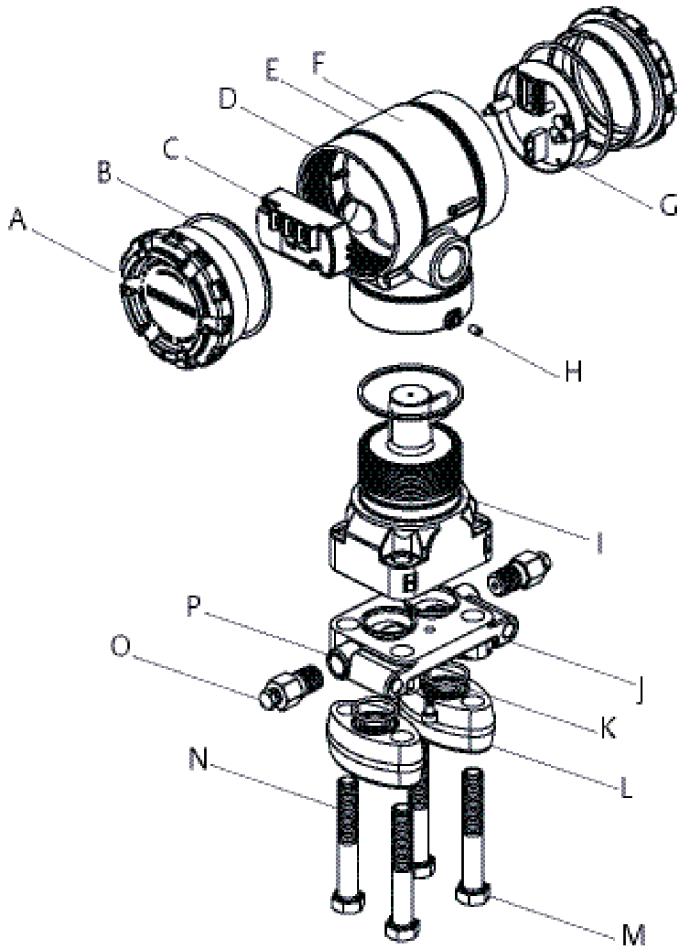

- A. Cover
- B. Cover O-ring
- C. Terminal block
- D. Electronics housing
- E. Local configuration buttons
- F. Nameplate
- G. Electronics board
- H. Housing rotation set screw (180° maximum housing rotation without further disassembly)
- I. Sensor module
- J. Process O-ring
- K. Flange adapter O-ring
- L. Flange alignment screw (not pressure retaining)
- M. Flange bolts
- N. Flange adapters
- O. Drain/vent valve
- P. Coplanar flange

Note

Local configuration buttons: Span and zero adjustment buttons are optional with 4–20 mA and 1–5 Vdc HART® Protocol. LOI buttons are optional for PROFIBUS® PA Protocol. Local configuration buttons are not available with FOUNDATION™ Fieldbus Protocol.

Figure 9: Rosemount 2051C Coplanar Flange

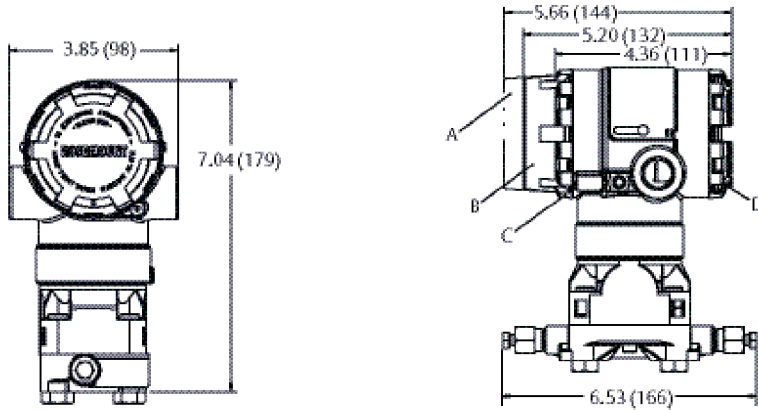

- A. FOUNDATION Fieldbus display cover
- B. HART display cover
- C. Transmitter circuitry
- D. Terminal connections

Dimensions are in inches (millimeters).

Figure 10: Rosemount 2051 Wireless Housing with Coplanar Platform

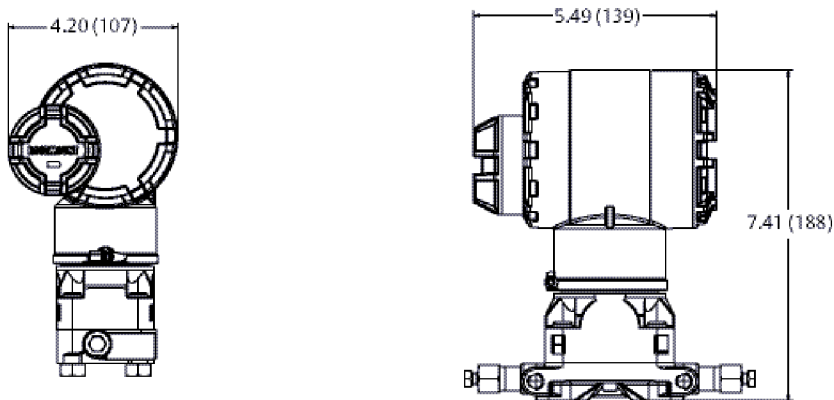

Dimensions are in inches (millimeters).

Figure 11: Rosemount 2051C Coplanar with Rosemount 305 Three-Valve Coplanar Integral Manifold

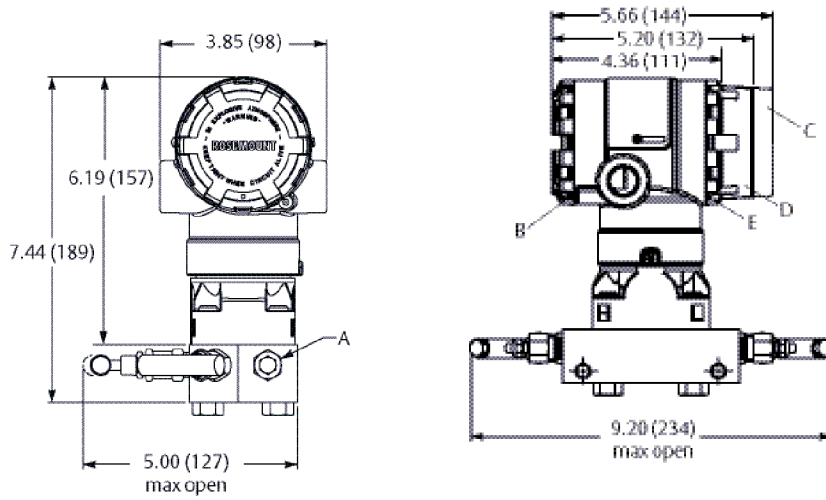

- A. Drain/vent valve
- B. Terminal connections
- C. FOUNDATION Fieldbus display cover

Dimensions are in inches (millimeters).

Figure 12: Coplanar Flange Mounting Configurations with Optional Bracket (B4) for 2-in. Pipe or Panel Mounting

Panel mounting

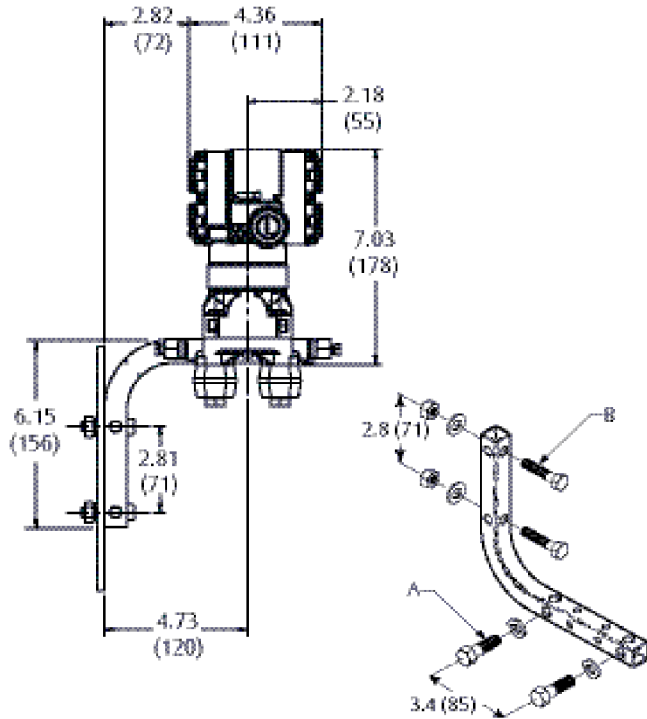

Pipe mounting

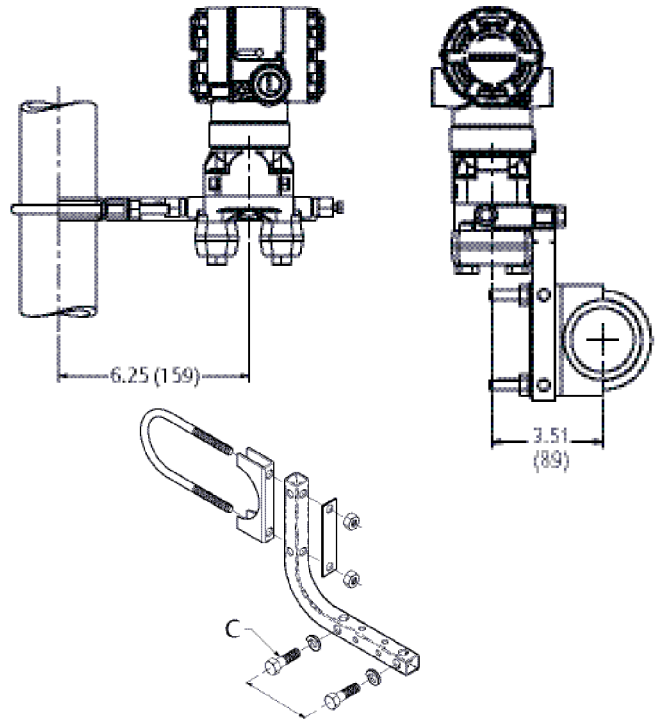

- A. 3/8-16 x 1 1/4 bolts for mounting to transmitter
- B. 5/16 x 1 1/2 bolts for panel mounting (not supplied)
- C. 2-in. U-bolt for pipe mounting

Dimensions are in inches (millimeters).

Figure 13: Rosemount 2051C Coplanar with Traditional Flange

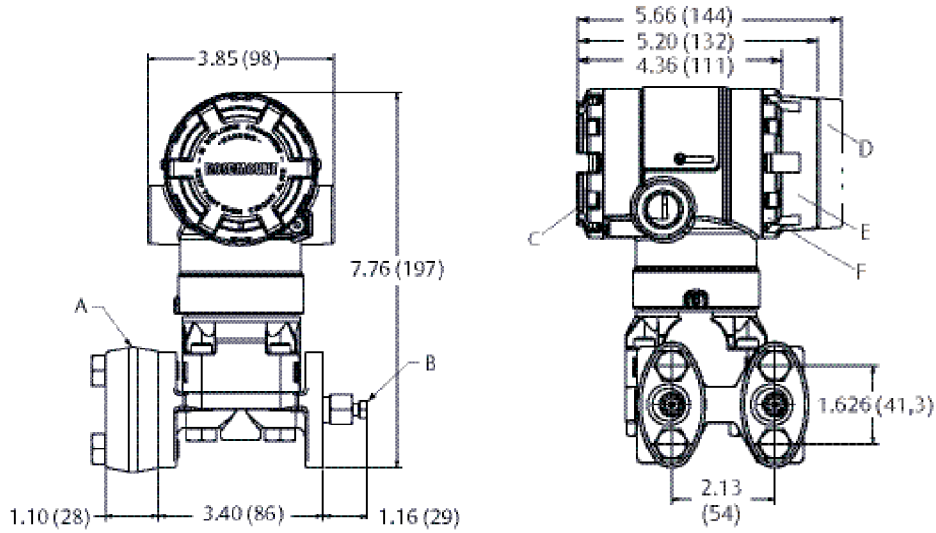

- A. 1/2-14 NPT flange adapter (optional)
- B. Drain/vent valve
- C. Terminal connections
- D. FOUNDATION Fieldbus display cover
- E. HART display cover
- F. Transmitter circuitry

Dimensions are in inches (millimeters).

Figure 14: Rosemount 2051C Coplanar with Rosemount 305 Three-Valve Traditional Integral Manifold

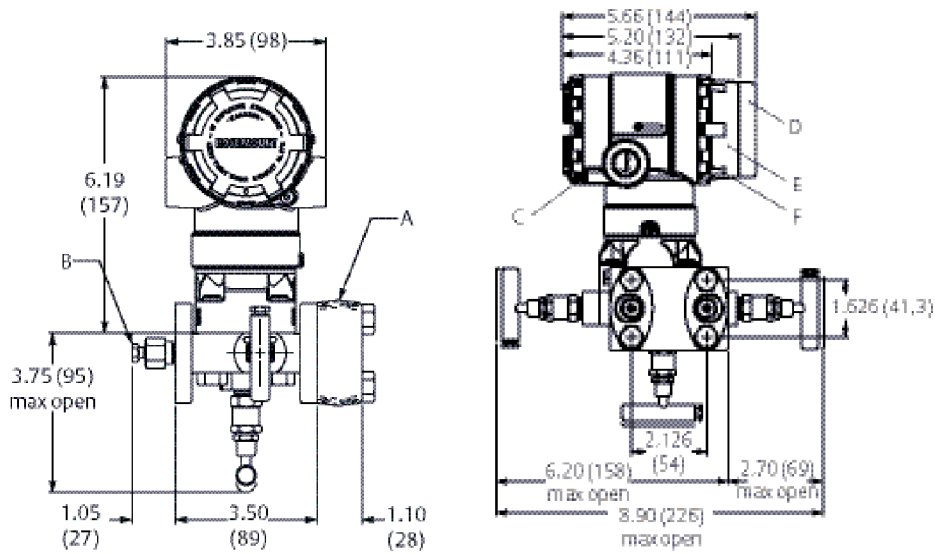

- A. 1/2-14 NPT flange adapter (optional)
- B. Drain/vent valve
- C. Terminal connections
- D. FOUNDATION Fieldbus display cover
- E. HART display cover
- F. Transmitter circuitry

Dimensions are in inches (millimeters).

Figure 15: Traditional Flange Mounting Configurations with Optional Brackets for 2-in. Pipe or Panel Mounting

Panel mount (bracket option B2/B8)

Pipe mount (bracket option B3/B9/BC)

Pipe mount (bracket option B1/B7/BA)

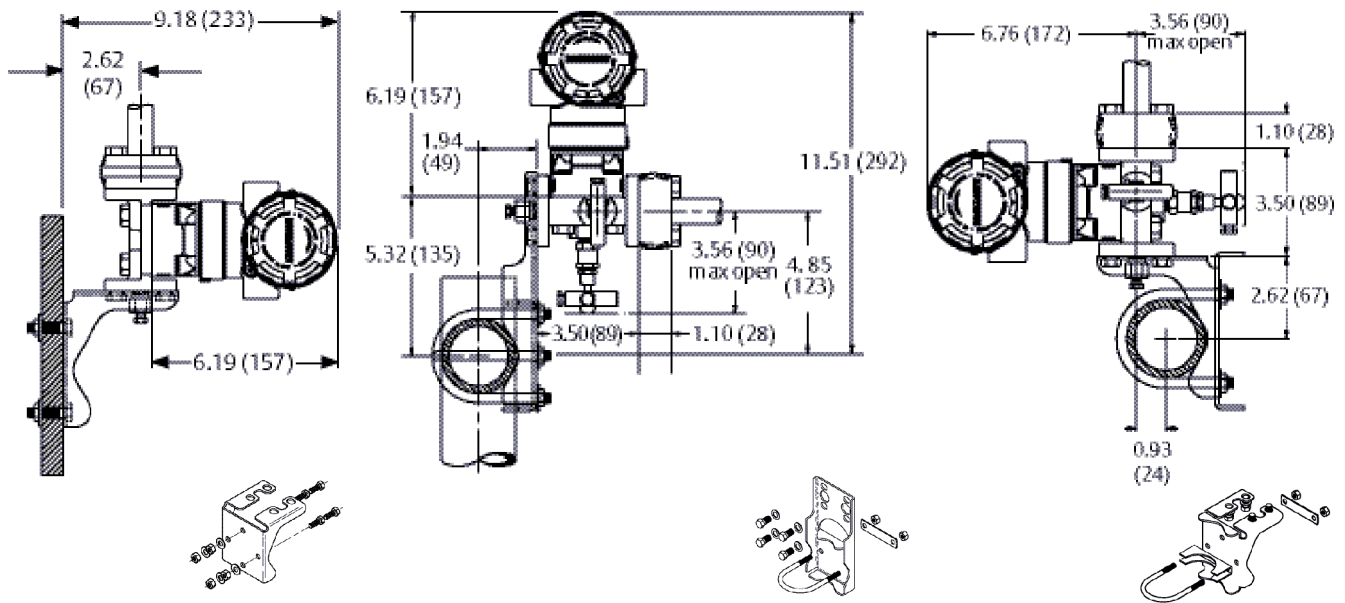

Dimensions are in inches (millimeters).

Figure 16: Rosemount 2051T

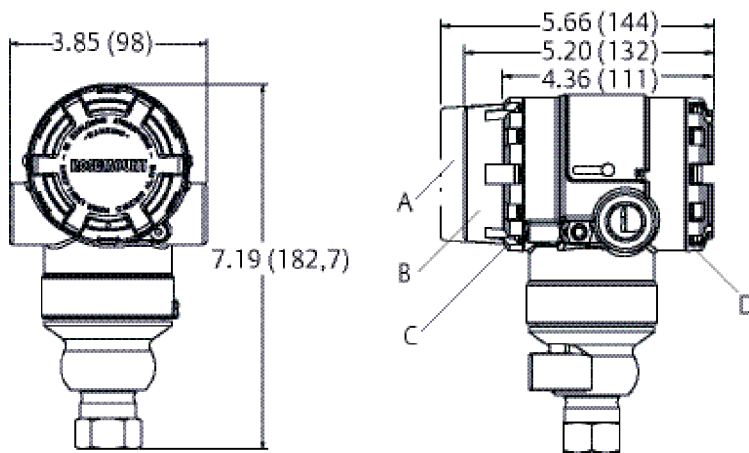

- A. FOUNDATION Fieldbus display cover
- B. HART display cover
- C. Transmitter circuitry
- D. Terminal connections

Dimensions are in inches (millimeters).

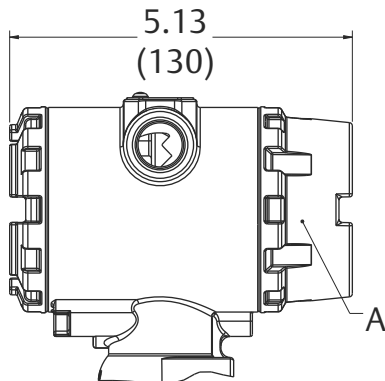
Figure 17: Rosemount 2051G with Optional Display

A. Digital display cover

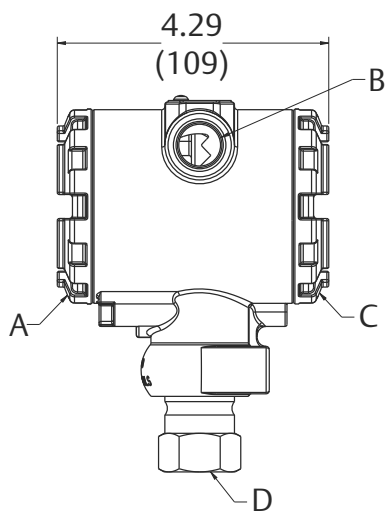
Figure 18: Rosemount 2051G Process Connection

- A. Field terminals
- B. Conduit connection
- C. Transmitter electronics
- D. $\frac{1}{2}$ -14 NPT female connection⁽²⁾

(2) RC $\frac{1}{2}$ female (PT $\frac{1}{2}$ female), and M20 female also available as options.

Figure 19: Rosemount 2051G Nameplate and Labels

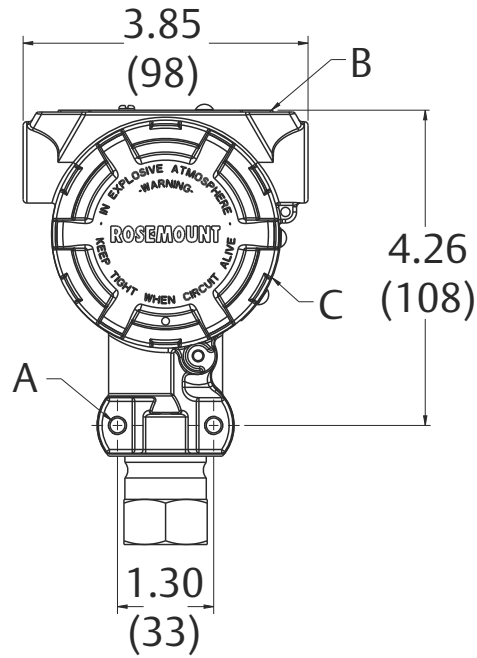

- A. Bracket mounting holes (1/4–20 UNC)
- B. Nameplate
- C. Certification label (located on side)

Figure 20: Rosemount 2051G with Optional Pipe Mounting Bracket

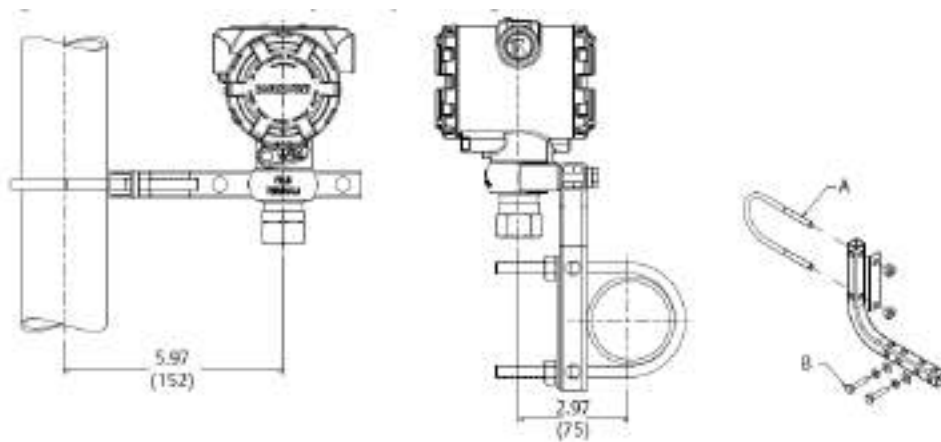

- A. 2-in. U-bolt for pipe mounting (clamp shown)
- B. 1/4 x 1 1/4 bolts for transmitter mounting

Dimensions are in inches (millimeters).

Figure 21: Rosemount 2051G with Optional Mounting Bracket

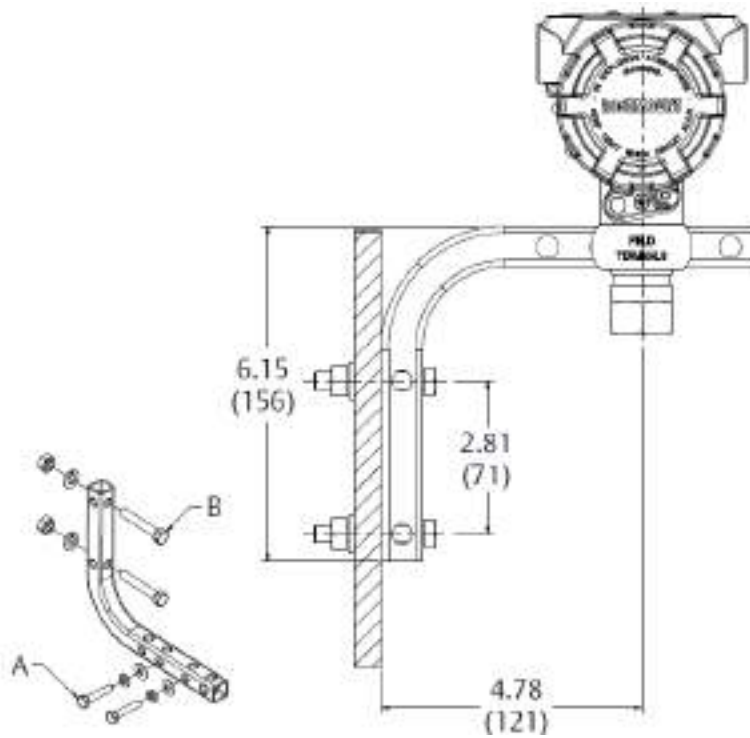

- A. 1/4 x 1 1/4 bolts for transmitter mounting
- B. 5/16 x 1/2 bolts for panel mounting (not supplied)

Dimensions are in inches (millimeters)

Figure 22: Rosemount 2051 Wireless Housing with In-line Platform

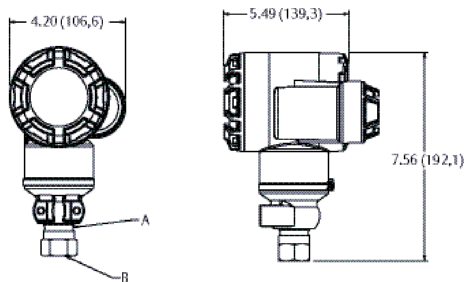

- A. U-bolt bracket
- B. 1/2-14 NPT female or G1/2 A DIN 16288 make process connection

Dimensions are in inches (millimeters).

Figure 23: Rosemount 2051T with Rosemount 306 Two-Valve Integral Manifold

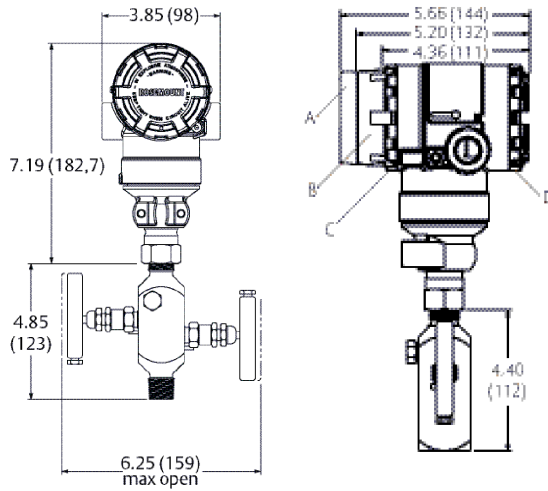

- A. FOUNDATION Fieldbus display cover
- B. HART display cover
- C. Transmitter circuitry
- D. Terminal connections

Dimensions are in inches (millimeters).

Figure 24: Rosemount 2051T Typical Mounting Configurations with Optional Mounting Bracket

Pipe mounting

Panel mounting

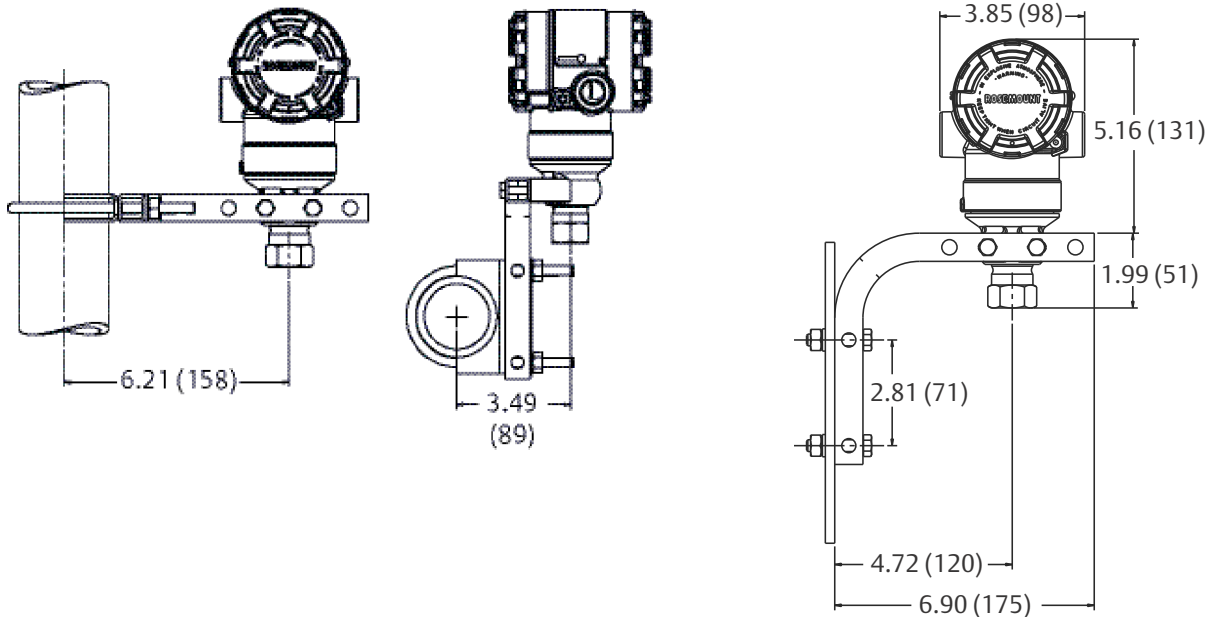

Dimensions are in inches (millimeters).

Figure 25: Rosemount 2051CFA Annubar Pak-Lok Flow Meter

The Rosemount Annubar Pak-Lok model is available up to Class 600 ANSI (1,440 psig at 100 °F [99 bar at 38°C]).

Front view

Side view

Top view

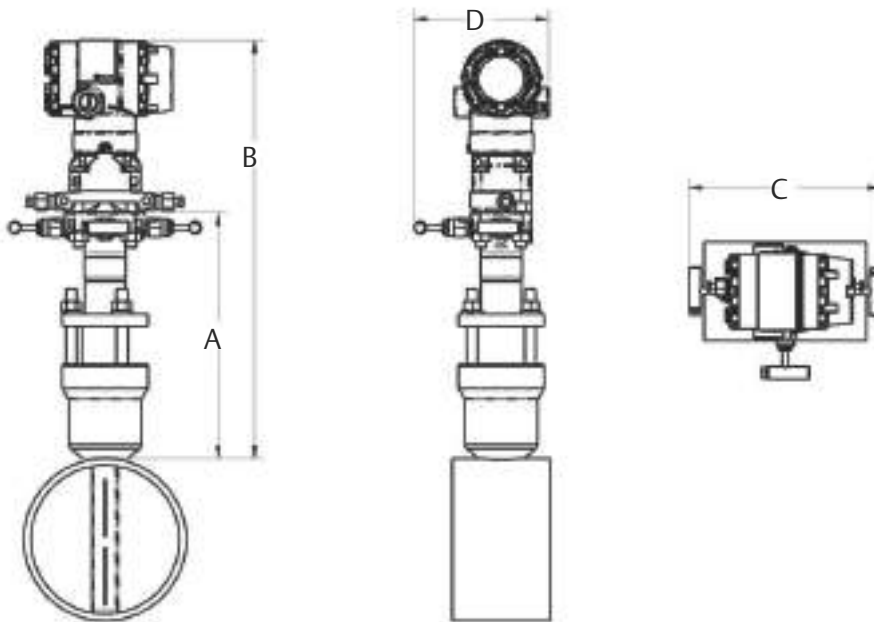

Table 26: Rosemount 2051CFA Annubar Pak-Lok Flow Meter Dimensional Data

Sensor size	A (max)	B (max)	C (max)	D (max)
1	8.50 (215.9)	14.55 (369.6)	9.00 (228.6)	6.00 (152.4)
2	11.00 (279.4)	16.30 (414.0)	9.00 (228.6)	6.00 (152.4)
3	12.00 (304.8)	19.05 (483.9)	9.00 (228.6)	6.00 (152.4)

Dimensions are in inches (millimeters).

Figure 26: Rosemount 2051CFC Compact Orifice Flow Meter

Orifice plate side view

Orifice plate front view

Orifice plate top view

Compact orifice plate (primary element type code P)

Orifice plate side view Orifice plate front view Orifice plate top view

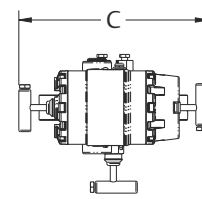
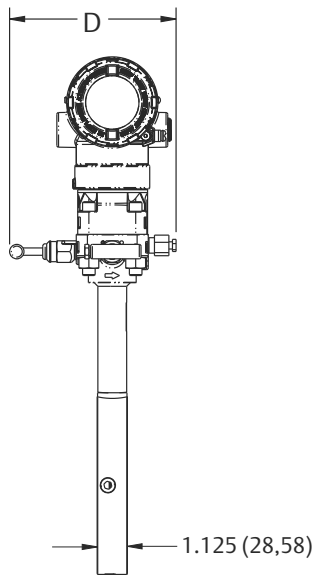
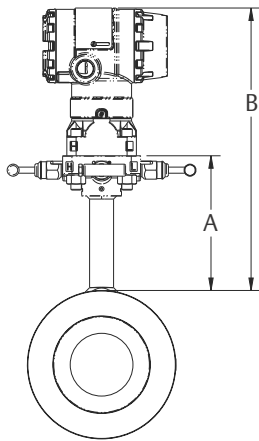

Compact orifice plate (primary element type code P)

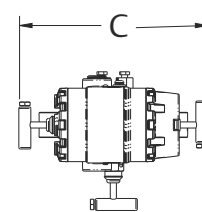
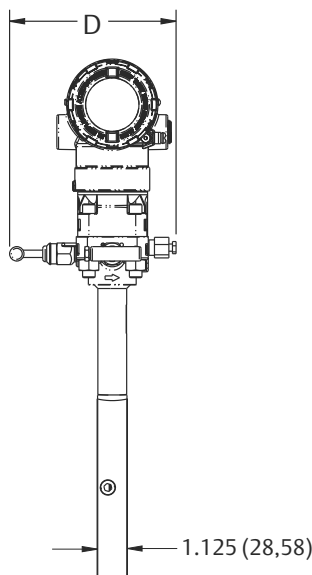
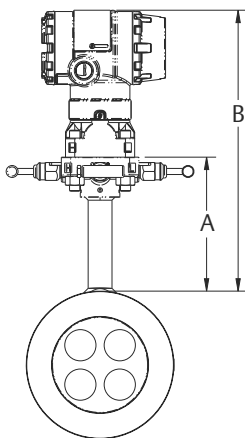
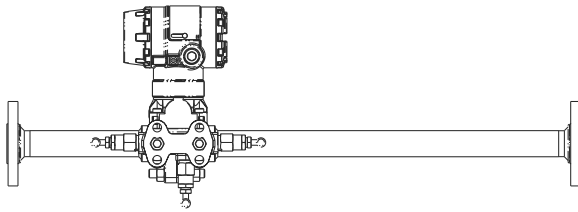

Table 27: Rosemount 2051CFC Dimensional Data

Primary element type	A	B	Transmitter height	C	D
Type P and C	5.62 (143)	Transmitter Height + A	6.27 (159)	7.75 (197) - closed 8.25 (210) - open	6.00 (152) - closed 6.25 (159) - open
Dimensions are in inches (millimeters).					

Figure 27: Rosemount 2051CFP Integral Orifice Flow Meter

Side view



Bottom view

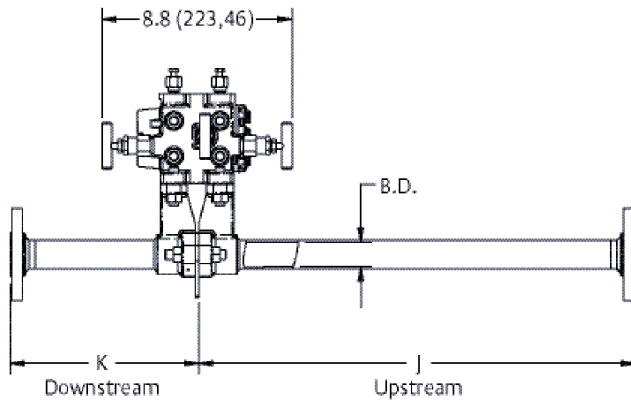

Front view

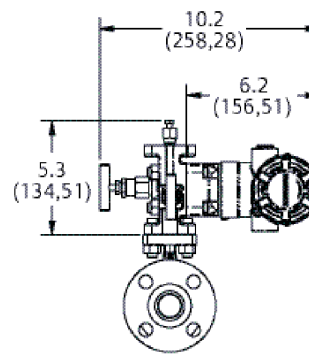

Dimensions are in inches (millimeters).

Table 28: Rosemount 2051CFP Dimensional Data

Dimension	Line size		
	½-in. (15 mm)	1-in. (25 mm)	1½-in. (40 mm)
J (beveled/threaded pipe ends)	12.54 (318,4)	20.24 (514,0)	28.44 (722,4)
J (RF slip-on, RTJ slip-on, RF-DIN slip on)	12.62 (320,4)	20.32 (516,0)	28.52 (724,4)
J (RF Class 150, weld neck)	14.37 (364,9)	22.37 (568,1)	30.82 (782,9)
J (RF Class 300, weld neck)	14.56 (369,8)	22.63 (574,7)	31.06 (789,0)
J (RF Class 600, weld neck)	14.81 (376,0)	22.88 (581,0)	31.38 (797,1)
K (beveled/threaded pipe ends)	5.74 (145,7)	8.75 (222,2)	11.91 (302,6)
K (RF slip-on, RTJ slip-on, RF-DIN slip on) ⁽¹⁾	5.82 (147,8)	8.83 (224,2)	11.99 (304,6)
K (RF Class 150, weld neck)	7.57 (192,3)	10.88 (276,3)	14.29 (363,1)
K (RF Class 300, weld neck)	7.76 (197,1)	11.14 (282,9)	14.53 (369,2)
K (RF Class 600, weld neck)	8.01 (203,4)	11.39 (289,2)	14.85 (377,2)
B.D. (bore diameter)	0.664 (16,87)	1.097 (27,86)	1.567 (39,80)

(1) Downstream length shown here includes plate thickness of 0.162-in. (4.11 mm).

Dimensions are in inches (millimeters).

Figure 28: Rosemount 2051L Liquid Level

2-in. flange configuration (flush mount only)

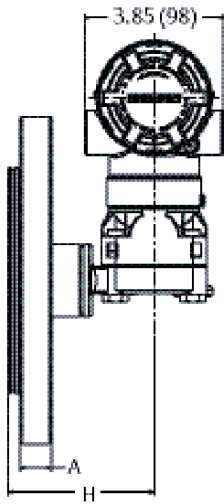

3- and 4-in. flange configuration

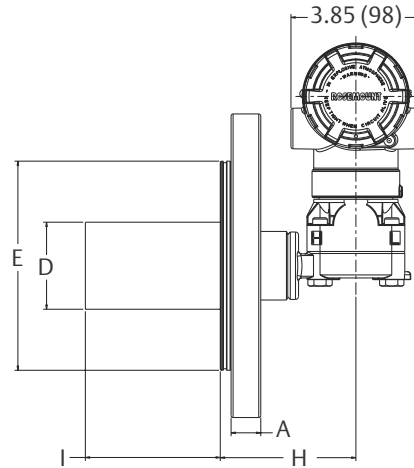

Optional flushing connection ring (lower housing)

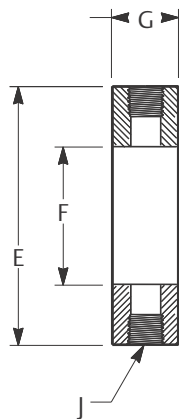

Diaphragm assembly and mounting flange

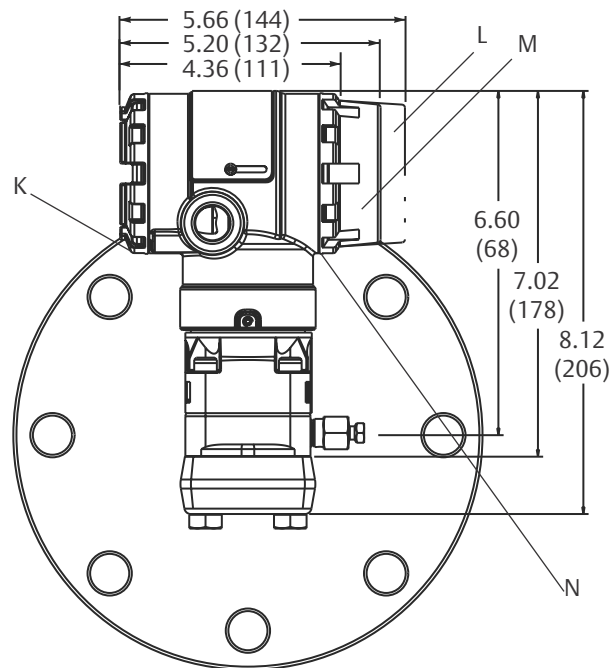
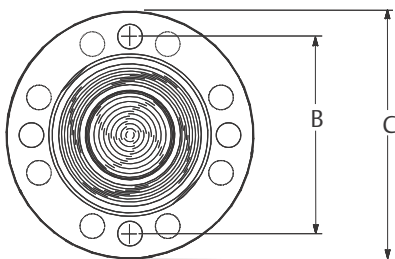

A–H. Refer to [Table 29](#)

I. 2-, 4-, or 6-in. extension (50.8, 101.6, 152.4)

J. Flushing connection

K. Terminal connections

L. FOUNDATION Fieldbus display cover

M. HART display cover

N. Transmitter circuitry

Dimensions are in inches (millimeters).

Table 29: 2051L Dimensional Specifications

Class ⁽¹⁾	Pipe size	Flange thickness A	Bolt circle diameter B	Outside diameter C	No. of bolts	Bolt hole diameter	Extension diameter ⁽¹⁾ D	O.D. gasket surface E
ASME B16.5 (ANSI) 150	2 (51)	0.69 (18)	4.75 (121)	6.0 (152)	4	0.75 (19)	N/A	3.6 (92)
	3 (76)	0.88 (22)	6.0 (152)	7.5 (191)	4	0.75 (19)	2.58 (66)	5.0 (127)
	4 (102)	0.88 (22)	7.5 (191)	9.0 (229)	8	0.75 (19)	3.5 (89)	6.2 (158)
ASME B16.5 (ANSI) 300	2 (51)	0.82 (21)	5.0 (127)	6.5 (165)	8	0.75 (19)	N/A	3.6 (92)
	3 (76)	1.06 (27)	6.62 (168)	8.25 (210)	8	0.88 (22)	2.58 (66)	5.0 (127)
	4 (102)	1.19 (30)	7.88 (200)	10.0 (254)	8	0.88 (22)	3.5 (89)	6.2 (158)
DIN 2501 PN 10–40	DN 50	20 mm	125 mm	165 mm	4	18 mm	N/A	4.0 (102)
DIN 2501 PN 25/40	DN 80	24 mm	160 mm	200 mm	8	18 mm	66 mm	5.4 (138)
	DN 100	24 mm	190 mm	235 mm	8	22 mm	89 mm	6.2 (158)

Dimensions are in inches (millimeters).

(1) Tolerances are -0.020 and $+0.040$ ($-0,51$ and $+1,02$).

Class ⁽¹⁾	Pipe size	Process side F	Lower housing G		H
			¼ NPT	½ NPT	
ASME B16.5 (ANSI) 150	2 (51)	2.12 (54)	0.97 (25)	1.31 (33)	5.65 (143)
	3 (76)	3.6 (91)	0.97 (25)	1.31 (33)	5.65 (143)
	4 (102)	3.6 (91)	0.97 (25)	1.31 (33)	5.65 (143)
ASME B16.5 (ANSI) 300	2 (51)	2.12 (54)	0.97 (25)	1.31 (33)	5.65 (143)
	3 (76)	3.6 (91)	0.97 (25)	1.31 (33)	5.65 (143)
	4 (102)	3.6 (91)	0.97 (25)	1.31 (33)	5.65 (143)
DIN 2501 PN 10–40	DN 50	2.4 (61)	0.97 (25)	1.31 (33)	5.65 (143)
DIN 2501 PN 25/40	DN 80	3.6 (91)	0.97 (25)	1.31 (33)	5.65 (143)
	DN 100	3.6 (91)	0.97 (25)	1.31 (33)	5.65 (143)

(1) Tolerances are -0.020 and $+0.040$ ($-0,51$ and $+1,02$).

Dimensions are in inches (millimeters).

Options

Standard configuration

Unless otherwise specified, transmitter is shipped as follows:

Engineering units	inH ₂ O (ranges 1, 2, and 3)
Differential/gage	psi (ranges 4–5)
Rosemount 2051TA	psi (all ranges)

4 mA (1 Vdc) ⁽¹⁾	0 (engineering units)
20 mA (5 Vdc) ⁽¹⁾ :	Upper range limit
Output:	Linear
Flange type	Specified model code option
Flange material	Specified model code option
O-ring material	Specified model code option
Drain/vent:	Specified model code option
LCD display	Installed or none
Alarm ⁽¹⁾	High
Software tag	(Blank)

(1) Not applicable to FOUNDATION Fieldbus, PROFIBUS PA, or wireless.

Custom configuration

If option code C1 is ordered, the customer may specify the following data in addition to the standard configuration parameters.

Note

Custom configurations are not applicable to FOUNDATION Fieldbus or PROFIBUS PA Protocols.

- Output information
- Transmitter information
- LCD display configuration
- Hardware selectable information
- Signal selection
- Wireless information
- Scaled variable

Refer to the Rosemount 2051 [Configuration Data Sheet](#) and the Rosemount 2051 Wireless [Configuration Data Sheet](#).

Tagging (3 options available)

Standard SST hardware tag is permanently affixed on transmitter. Tag character height is 0.125-in. (3,18 mm), 84 characters maximum.

Tag may be wired to the transmitter nameplate upon request, 85 characters maximum.

Tag may be stored in transmitter memory. Character limit is dependent on protocol.

- HART® Revision 5: 8 characters
- HART Revision 7 and wireless: 32 characters
- FOUNDATION Fieldbus: 32 characters
- PROFIBUS PA: 32 characters

Commissioning tags are temporarily attached to all transmitters. The tag indicates the device ID and allows an area for writing the location.

Note

The commissioning tag applies only to FOUNDATION Fieldbus Protocol.

Optional Rosemount 304, 305, or 306 Integral Manifolds

Factory assembled to Rosemount 2051C, 2051T, and 2051G Transmitters. Refer to the Rosemount Manifolds [Product Data Sheet](#) for additional information.

Other seals

Refer to the Rosemount DP Level Transmitters and 1199 Seal Systems [Product Data Sheet](#) for additional information.

Output information

Output range points must be the same unit of measure. Available units of measure include:

Pressure		
atm	mmH ₂ O at 4 °C ⁽¹⁾	ftH ₂ O at 4 °C ⁽¹⁾
mbar	ftH ₂ O	psi
bar	inH ₂ O at 60 °F ⁽¹⁾	torr
inH ₂ O	Psf ⁽¹⁾	cmH ₂ O at 4 °C ⁽¹⁾
inHg	g/cm ²	cmHg at 0 °C ⁽¹⁾
hPa ⁽¹⁾	kg/cm ²	ftH ₂ O at 60 °F ⁽¹⁾
mHg at 0 °C ⁽¹⁾	Pa	mH ₂ O at 4 °C ⁽¹⁾
inH ₂ O at 4 °C ⁽¹⁾	kPa	mHg at 0 °C ⁽¹⁾
mmH ₂ O	MPa ⁽¹⁾⁽²⁾	hPa ⁽¹⁾
mmHg	kg/m ²⁽¹⁾	
Flow ⁽²⁾⁽³⁾		
bbbl	kg	cm ³
ft ³	lb	m ³
gal	L	ton
Level ⁽³⁾		
%	ft	cm
in	mm	

(1) Available with enhanced Rosemount 2051 and wireless.

(2) Available on PROFIBUS PA Protocol.

(3) All flow units are available per second, minute, hour or day.

Display and interface options

M4 Digital display with LOI

- Available for 4–20 mA HART®, 4–20 mA HART Low Power, and PROFIBUS® PA Protocols.

M5 Digital display

- 2-line, 5-digit LCD display for 4–20 mA HART Protocol
- 2-line, 5-digit LCD display for HART 1–5 Vdc Low Power Protocol
- 2-line, 8-digit LCD display for FOUNDATION™ Fieldbus and PROFIBUS PA Protocols
- 3-line, 7-digit LCD display for wireless
- Direct reading of digital data for higher accuracy
- Displays user-defined flow, level, volume, or pressure units
- Displays diagnostic messages for local troubleshooting
- 90° rotation capability for easy viewing

Configuration buttons

Rosemount 2051 requires option D4 (analog zero and span), DZ (digital trim), M4 (LOI) for local configuration buttons.

Transient protection

T1 Integral transient protection terminal block

Meets IEEE C62.41, category location B

- 6 kV crest (0.5 μ s–100 kHz)
- 3 kA crest (8 x 20 microseconds)
- 6 kV crest (1.2 x 50 microseconds)

Bolts for flanges and adapters

Standard material is plated carbon steel per ASTM A449, type 1

L4 Austenitic 316 SST bolts

L5 ASTM A 193, Grade B7M bolts

L6 Alloy K-500 bolts

L8 ASTM A 193 Class 2, Grade B8M bolts

Conduit plug

DO 316 SST conduit plug

Single 316 SST conduit plug replaces CS plug

Rosemount 2051C coplanar flange and 2051T bracket option

B4 Bracket for 2-in. pipe or panel mounting

- For use with the standard coplanar flange configuration

- Bracket for mounting of transmitter on 2-in. pipe or panel
- SST construction with SST bolts

Rosemount 2051C traditional flange bracket options

B1 Bracket for 2-in. pipe mounting

- For use with the traditional flange option
- Bracket for mounting on 2-in. pipe
- CS construction with CS bolts
- Coated with polyurethane paint

B2 Bracket for panel mounting

- For use with the traditional flange option
- Bracket for mounting transmitter on wall or panel
- CS construction with CS bolts
- Coated with polyurethane paint

B3 Flat bracket for 2-in. pipe mounting

- For use with the traditional flange option
- Bracket for vertical mounting of transmitter on 2-in. pipe
- Carbon steel construction with carbon steel bolts
- Coated with polyurethane paint

B7 B1 bracket with SST bolts

- Same bracket as the B1 option with Series 300 SST bolts

B8 B2 bracket with SST bolts

- Same bracket as the B2 option with Series 300 SST bolts

B9 B3 bracket with SST bolts

- Same bracket as the B3 option with Series 300 SST bolts

BA SST B1 bracket with SST bolts

- B1 bracket in SST with Series 300 SST bolts

BC SST B3 bracket with SST bolts

- B3 bracket in stainless steel with Series 300 SST bolts

For more information: www.emerson.com

©2021 Emerson. All rights reserved.

Emerson Terms and Conditions of Sale are available upon request. The Emerson logo is a trademark and service mark of Emerson Electric Co. Rosemount is a mark of one of the Emerson family of companies. All other marks are the property of their respective owners.

ROSEMOUNT™

