

Compressed air counter shaft probe DN40 - DN250

testo 6448



Possibility of installation under pressure

Measurement of flow velocity in the measuring range from 0 to 160 m/s; consumption measurement in m³ and media temperature in °C

Recoil protection and ball valve ensure fast and safe installation and deinstallation

Highest flexibility thanks to different signal outputs:

- Analog output 4 to 20 mA (4-wire)
- Pulse output
- 2 switching outputs (consumption or volume flow-dependent)

Integrated totalizer, also without additional evaluation unit

Operating menu with LED display

Shaft probe

The compressed air counter testo 6448 is designed for the recording and monitoring of compressed air consumption, and thus not only for the identification of leakages in compressed air systems and the allocation of costs by consumption, but also for the implementation of peak load management. The shaft probe can be used for measurements on different pipe diameters.

An optional drilling clamp allows the exact positional installation of the sensor, without the need for welding work. The affected compressed air pipeline can remain pressurized when installing the drilling clamp or for sensor maintenance/exchange.

Patented recoil protection

The recoil protection guarantees high security for the commissioner, and combines three functions in one instrument:

1. the recoil protection, i.e. the sensor can only be inserted in one direction during installation.
2. the seal to the process, i.e. thanks to the O-ring, compressed air cannot escape during installation.
3. the positional fixing, since a penetration depth and positioning which is exact to the millimeter, similar to a car's clutch, is possible.

Technical data

Parameters

Flow velocity

Selectable units	m/s
Measuring range ¹	0 to 160 m/s
Accuracy	±3 % of meas. value ±3 % of fsv (at room temperature)
Sensor	Thermal, glass-coated ceramic sensor (calorimetric measurement procedure)
Response time	< 0.1 sec (for damping parameter = 0), delayable via operating menu (0 to 1 sec)

(Norm) volume flow

Selectable units	m ³ /h, m ³ /min, m ³
Measuring range ¹	Maximum measuring range of volume flow is dependent on inner pipe diameter (see page 3)

Temperature

Unit	°C
Measuring range	0 to +60 °C / 32 °F to +140 °F

Inputs and outputs

Analog outputs

Output type	4 to 20 mA (4-wire) freely scalable between zero and measuring range end
Load	max. 500 Ω

Further outputs

Pulse output	Pulse speed freely settable in 1 m ³ steps
Switch output	2 switch outputs, parameterizable (consumption or volume flow-dependent, NC, NO, hysteresis, window), loadable with max. 20 to 30 VDC or 250 mA each, switch status is displayed via 2 LEDs

Supply

Voltage supply	19 to 30 V DC
Current consumption	<100 mA
Connection	M12 x 1 plug, loadable up to 250 mA, short-circuit-proof (synchronized), reverse-polarity-proof, overload-proof

General technical data

Design

Material housing	PBT-GF 20, PC (APEC), Makrolon, V2A (1.4301), Viton
Weight	850 g

Display

Display	4-figure alphanumerical display, two operating buttons, operating menu, LED (4 x green for phys. units, 3 x yellow for display x 1,000 or switch status)
---------	--

Operation

Parameterization	2 operating buttons
------------------	---------------------

Miscellaneous

Protection class	IP 65/III
EMC	according to guideline 89/336 EEC
Media contact	V2A (1.4301), PEEK, polyester, Viton, anodized aluminium, glass-coated ceramics
Norm reference	Calculation of volume flow due to manual input possibility of temperature, humidity and pressure. Works settings: 15 °C, 1013.25 hPa, 0 %RH

Operating conditions

Humidity (sensor)	rel. humidity < 90 %RH
Operating temperature (housing)	0 to +60 °C (+32 to +140 °F)
Storage temperature	-25 to +85 °C (-13 to +185 °F)
Measurement medium	Compressed air, with special calibration also CO ₂ or N ₂
Process pressure	PN 16 (max 16bar/232psi)
Pressure tightness/ pipe clamp	16 bar (max.) for DN40-DN200; 10 bar (max.) for DN250
Air quality	ISO 8573: recommended classes 1-4-1

¹ Specifications according to DIN 2533 (+15 °C, 1013.25 hPa, 0 %RH)

Technical drawings

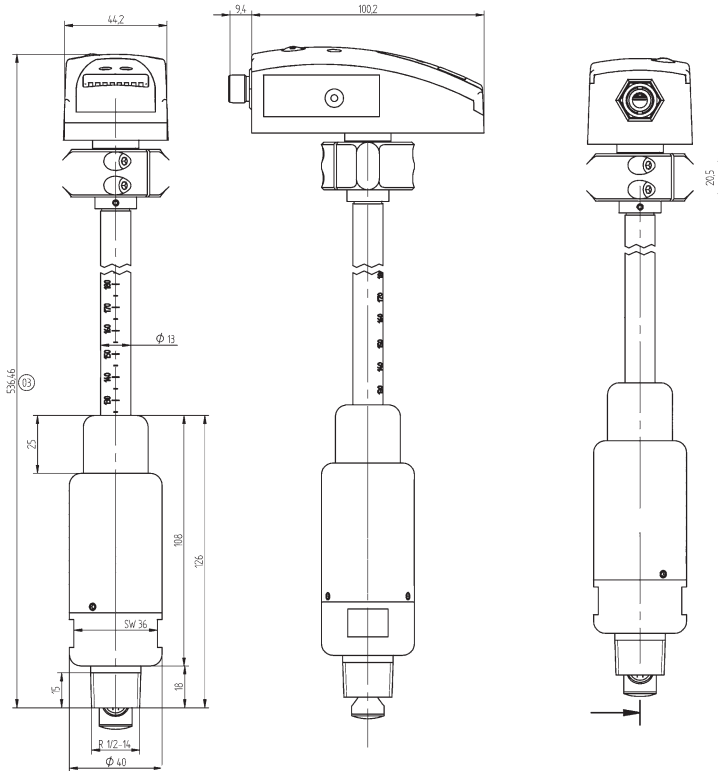

Measuring range volume flow according to DIN2533

Version	160 m/s
DN 40	600 m ³ /h
DN 50	1000 m ³ /h
DN 65	1880 m ³ /h
DN 80	2600 m ³ /h
DN 100	4400 m ³ /h
DN 125	6700 m ³ /h
DN 150	9950 m ³ /h
DN 200	17000 m ³ /h
DN 250	25650 m ³ /h

Electrical connection

5 options

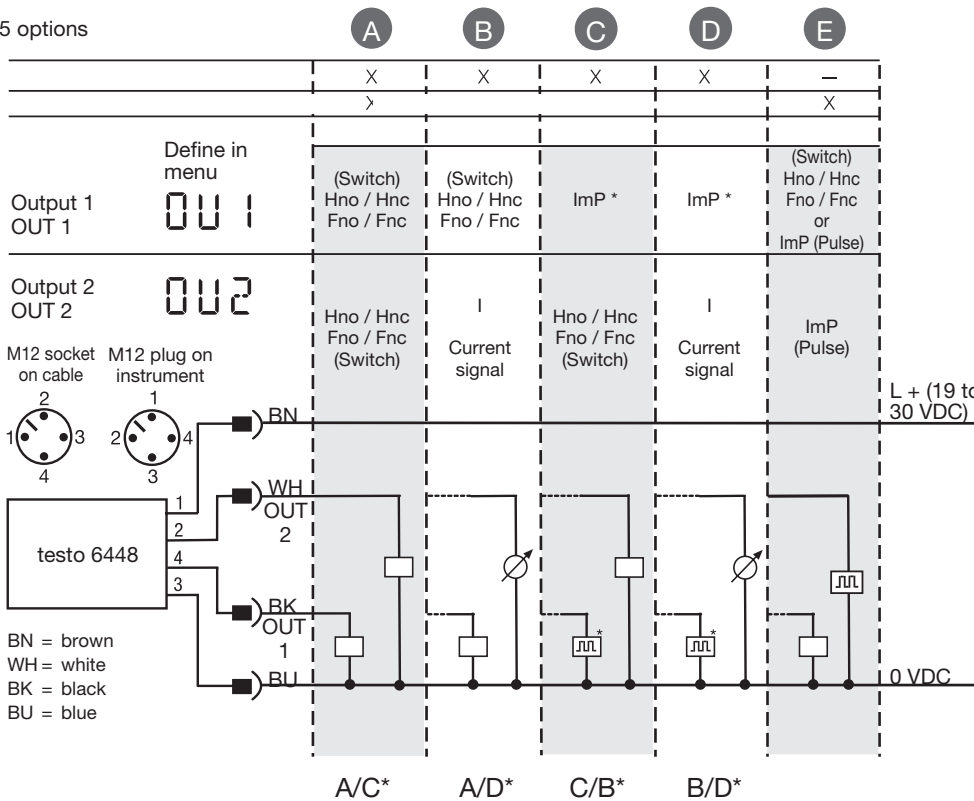

Terminal allocation	
1	Supply connection 19 to 30 VDC (+) / brown
2	OUT 2 (analog output (4 to 20 mA) or switch output / white
3	Supply connection 0 V (-) / blue
4	OUT 1 (pulse output or switch output) / black
Wire colours for cable 0699 3393	

* If menu selection ImPR = Yes -> Pulse output
If menu selection ImPR = No -> Switch output (pre-selection counter)

Options / Ordering example

Order data testo 6448

AXXX configuration
 BXX Drilling clamp selection
 CXX Measurement fitting selection
 DX Drilling tool selection

AXXX configuration

A0 accessories only *
 A1 transmitter
 AA1 160 m/s
 AB0 standard configuration
 AC0 Air (compressed air)
 AC1 Alternative gas: nitrogen
 AC2 Alternative gas: CO₂
 AD1 ISO calibration protocol m/s
 at 6 points
 AD2 ISO calibration protocol m³/h
 at 6 points for specific
 nominal diameter
 (pls. indicate diameter)
 AE0 Standard length 285 mm
 (for DN40 to DN65)
 AE1 Length variant 435 mm
 (for DN80 to DN250)

* If this selection is made, further configuration
 AXX is not necessary. Continue with BX.

**Further Configuration necessary! Continue
 with AXX.

***A connection cable, e.g. order no. 0699
 3393 is required for operation.

BXX Drilling clamp selection

B00 without drilling clamp
 B01 drilling clamp DN40
 B02 drilling clamp DN50
 B03 drilling clamp DN65
 B04 drilling clamp DN80
 B05 drilling clamp DN100
 B06 drilling clamp DN125
 B07 drilling clamp DN150
 B08 drilling clamp DN200
 B09 drilling clamp DN250

CXX Measurement fitting selection

C00 without measurement fitting / without ball
 valve
 C01 measurement fitting (incl. ball valve for
 other meas. parameter, e.g. dewpoint
 transmitter testo 6740)
 C02 ball valve (DN15)

DX Drilling tool selection

D0 without drilling tool
 D1 with drilling tool

Ordering example

Order code for transmitter testo 6448 –
 Compressed air counter shaft probe

- With transmitter incl. recoil protection
- 160 m/s
- Air (compressed air)
- 6 point calibration
- Length variant 435 mm
 (for DN80 to DN250)
- Without drilling clamp
- Without measurement fitting /
 without ball valve
- without drilling tool

-> 0555 6448 A1 AA1 AC0 AD1 AE1
 B00 C00 D0

Order code for transmitter testo 6448 –
 drilling clamp DN40:

- Accessories
- With drilling clamp DN40
- Without measurement fitting /
 without ball valve
- without drilling tool

-> 0555 6448 A0 B01 C00 D0